

# Surveying and Mapping Simplified

*A Book of Suggestions for those Who  
Adventure with Maps*

BY

**KENNETH C. SPARROW**

B.Sc., A.K.C.

*Group Scoutmaster, Devonport High School*

GLASGOW  
BROWN, SON & FERGUSON, LTD.  
52 TO 58 DAENLEY STREET

*Printed 1941*

*Printed and made in Great Britain by*  
BROWN, SON & FERGUSON, LTD., GLASGOW, S.1

Downloaded from:  
"The Dump" at ScoutsCan.com  
<http://www.thedump.scoutscan.com/>

Thanks to Dennis Trimble for providing this booklet.



Editor's Note:

The reader is reminded that these texts have been written a long time ago. Consequently, they may use some terms or express sentiments which were current at the time, regardless of what we may think of them at the beginning of the 21<sup>st</sup> century. For reasons of historical accuracy they have been preserved in their original form.

If you find them offensive, we ask you to please delete this file from your system.

This and other traditional Scouting texts may be downloaded from The Dump.

**FOREWORD.**

A KNOWLEDGE of Maps and Mapping is very necessary, not only to all Scouts but to almost everyone, and particularly now when it is so often essential to give an accurate description of the position of a given place.

The Author is an active Scoutmaster running a splendid Troop, and has every opportunity of instructing his Scouts in a very practical manner how to read and understand Ordnance Survey maps, realising their value as an aid to self-reliance and adventure under modern conditions.

This book is so essentially practical that it will be of great value to Scouters and Leaders of all Youth Organisations.

(Sgd.) V. R. WINNICOTT,  
*District Commissioner,  
Plymouth & District Scouts Assn.  
Governor, Launceston College,  
JANUARY, 1941. Cornwall.*

NOTE TO READERS.

THIS book is written in the hope that it will be of use to those who go out into the open air in search of health, recreation and adventure, taking with them a MAP as an aid. The book is perhaps written primarily for Scouts to assist them with their various Scout tests, but there will be others, no doubt, who are interested in map-making and in map-using who will derive help from this book. Mapping and surveying and the drawing of plans enter into the life of most people today. The motorist relies on his A.A. route-map; the hiker on his 1-inch Ordnance Survey map; the visitor to a holiday resort on the street plans and information maps issued by the Publicity Bureau; the handyman makes a plan of a room preparatory to covering it with lino or gets out the plans of a new henhouse; scientists make land utilisation or forestry surveys; the Surveyor and his men accurately depict pieces of land on paper, and so on. The representation of the nature of the land in large areas or small is by no means a modern invention as will be shown in this book. To get full enjoyment and advice from a map it is desirable to know something about the way in which maps are made. A map of any description is a convenient way of conveying a lot of information by means of signs and symbols in a short space, that is, in handy form for use in the field. The book does not pretend to be an exhaustive account of mapping, but is simply a practical account for the benefit of users of maps who do not possess a specialised knowledge.

PLYMOUTH

S/M D. H. S.

**CONTENTS.**

**CHAPTER**

- I. – Maps and Map Symbols – Symbols used in the Ordnance Survey – Conventional Signs used in Field Sketching – Lettering
- II. – How to make a Simple Map – Plan of a Room – Map of a Small Area of Land – The Ray Method of Mapping – Triangulation
- III. – How to Enlarge or Reduce a Simple Sketch Map
- IV. – The True North and the Magnetic North – How to show the True and Magnetic North in making a Map – Setting a Map
- V. – Scales – Representation of Scales – Division of Scales – Construction of Scales
- VI. – Scout Estimation Tests – Measuring – Handy Self-measures – Numbers – Distances – Heights – Methods of Checking
- VII. – Useful Information about Maps
- VIII. – Gradients and Slopes – How to Measure a Gradient
- IX. – The Ordnance Survey – Ordnance Survey Maps – The Triangulation of Great Britain

## SCOUT BADGES.



### SURVEYOR.

(A Compass and Ruler.)

#### 1. Surveyor Badge.

Map correctly from the country itself: –

1. By triangulation an area not less than 10 acres in extent, at a scale not less than 12 inches to one mile: and
2. By compass and field-book a road map of not less than one mile of road showing all main features and objects within a reasonable distance on either side to a scale of not less than 12 inches to a mile – field-book must be produced for inspection.
3. Be able to enlarge or reduce any portion of a map which the examiner may determine to such scale as he may prescribe.

#### 2. First Class Badge.

*Estimation.* – Estimate, without apparatus, distance, numbers and height, within 25 per cent, error each side.

*Mapping.* – Read and be able to use a 1-inch Ordnance Survey map (or its local equivalent) and draw an intelligible rough sketch map. Use a compass and point out a compass direction by day or night without the help of a compass.

#### 3. Second Class Badge.

*Compass.* – Demonstrate the practical use of a compass and know the 16 principal points.

#### 4. Pathfinder Badge.

“Have a general knowledge of the district so as to be able to guide strangers by day or night within a 5-mile radius and give them general directions how to get to the principal suburbs, districts or towns within a 25-mile radius.”

#### 5. Explorer Badge.

“In all cases a log of his expeditions must be submitted, giving mileage, and accompanied, as far as possible, by explanatory sketches, photographs, maps, etc.”

#### 6. Cyclist Badge.

“. . . understand the system of road numbering, and be able to read a road map.”

#### 7. Camper Badge.

“. . . know the principal points to look for in the selection of a Patrol or Troop camp site, and describe with rough plan how he would lay out a Patrol camp with reference to tent, kitchen, etc.”

**8. Climber Badge.**

“Draw an intelligible sketch map showing the principal routes to the summit of peaks and to points of interest, the nearest telephone and doctor to any point in the area, inns and places of refreshment. Find his way to a given point in a mountainous area, using a 1-inch Ordnance Survey map (or its local equivalent) and compass, and display mountaineering ability.”

NOTE. – The above extracts will give the Scout reader some idea of the use made of mapping and surveying in the Scout Badge tests.

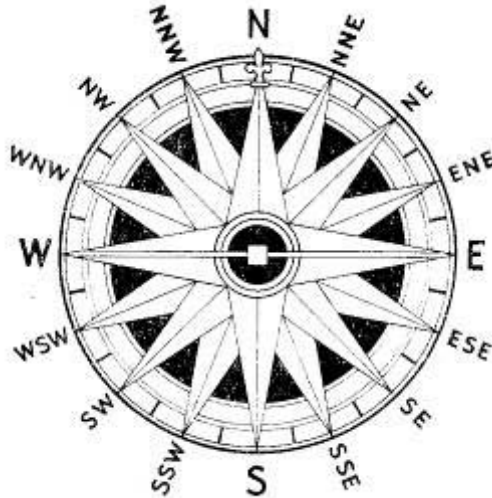

## CHAPTER I.

### MAPS AND MAP SYMBOLS.

THERE is evidence that man has long been interested in recording information by means of signs and symbols. Some of his earliest efforts have been found scratched on the walls of caves – crude pictures of wild animals, cooking utensils or simple plans. It is said that maps of a kind were in use in Egypt over 3000 years ago, and records show that the Chinese used maps at a very early date. Some years ago an interesting article appeared in one of the Scout papers in which a geographer traced the history of map-making. He pointed out that the earliest known maps in this country were carvings on the rocks made by the ancient Britons to mark the positions, of the various camps and tracks between them. Many of these still remain and are known as “cup-and-ring” stones, the signs having something to do with religious symbolism. On Dartmoor there are many traces of the activities of ancient British peoples. The same writer, Sydney Moorhouse, F.R.G.S., records that the first real map-maker, Ptolemy, who was born in 77 A.D. and died at Alexandria in 147 A.D., made a map of Britain about the year 140 A.D. His map was used until the middle of the fifteenth century. The Egyptians were practical surveyors surveying the land for taxation purposes. They also found it necessary to hold periodical new surveys in the Nile Valley as the annual flooding of the Nile played havoc with the official land boundaries. In addition to being practical surveyors they were also travellers and learnt the value of making route maps to assist the traveller. Besides the Egyptians and the Chinese, the Greeks and the Romans were interested in map-making. The Romans carried out a most important survey when they constructed a plan of Rome. They, too, were interested in the practical value of mapping, being a military nation possessing large territories.

It may be said that the capacity to understand the nature of maps is possessed by nearly all peoples – even the peoples we are inclined to call “savages”. Many of the primitive peoples are wandering or nomadic tribes to whom a knowledge of the general geography of the land is of practical importance. Such travelling peoples are bound to possess more “map-sense” than sedentary tribes; and so it is that we find that the Esquimaux have a practical knowledge of the Arctic waters, and the hill tribes of the Indian North-West Frontier a knowledge of the mountainous region in which they live. From practical issues such as these modern map-making has arisen.

Quoting from the article already mentioned: “An exceedingly ancient map can be seen in Hereford Cathedral. It is known as the *Mappe Mundi* and was drawn by Richard de Bello, an English monk of the thirteenth century. The designer seems to have been less concerned with the actual mapping of the world than with his own religious beliefs, for he has made Jerusalem the centre of the world and placed the other countries around it.

Specially interesting are the quaint symbols which he employed in an endeavour to portray life in the different places. Mermaids swim about in the Mediterranean, a horde of monkeys seem to have taken possession of Norway, and India boasts a queer kind of native with only one foot which could be turned upwards from the ground and spread over the head after the style of a sunshade!”

This method of illustrating important geographical features by means of small pictures was popular with British map-makers until comparatively recent times. The pictures have now been replaced by useful signs and symbols some of which will be illustrated below. A visit to the local museum would probably result in the viewing of copies of some of the early British maps, where it would be possible to see the difference between the early attempts giving very little real information and the more modern maps whose interpretation provides the traveller with a wealth of material.

## Surveying & Mapping Simplified

The signs and symbols given below are the ones used on the Ordnance Survey maps. The Ordnance Survey was founded in 1791, its original purpose being the construction of a map of this country on the scale of 1-inch/1 mm., i.e. 1/63,360.

### SYMBOLS USED — in the — ORDNANCE SURVEY. 1" = 1 MILE. IN OUTLINE.

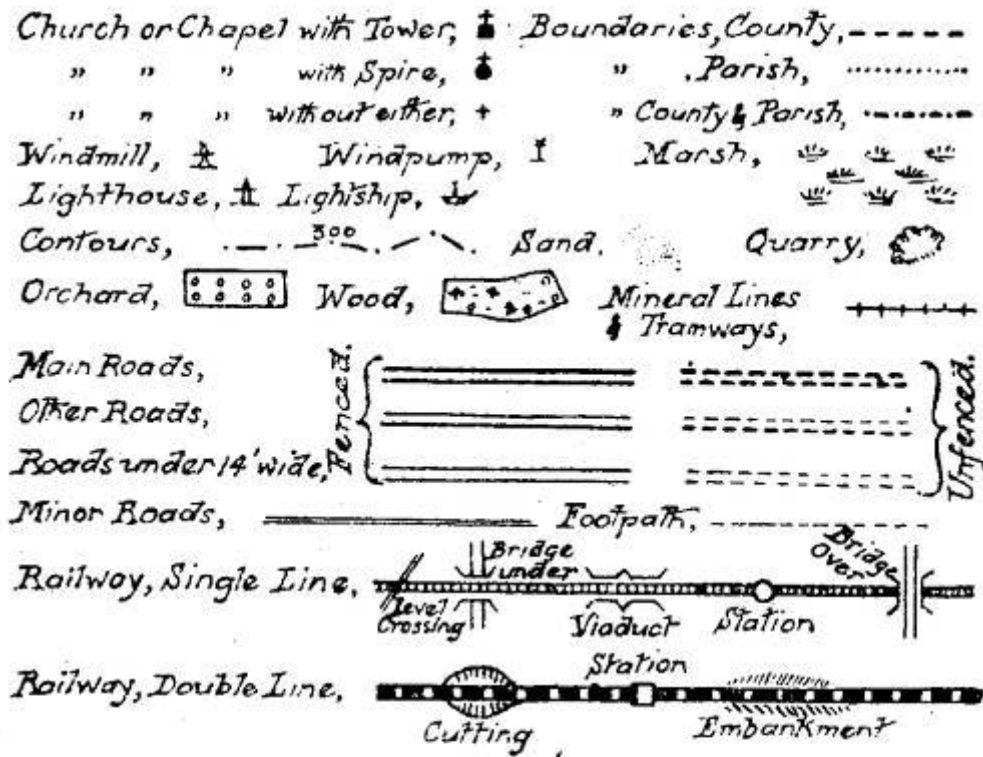

### IN COLOUR. (Where different from above.)

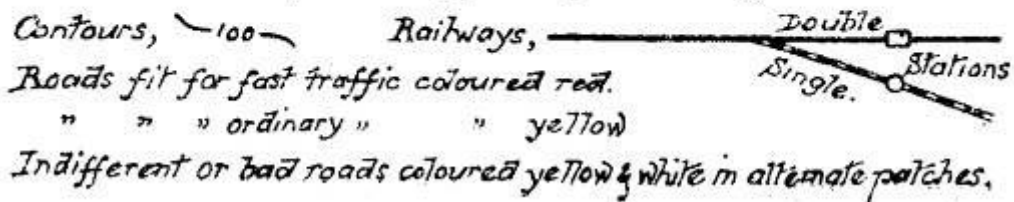

**CONVENTIONAL SIGNS**

— used in —

**FIELD SKETCHING.**

(where different from Ordnance Survey)

— Woods. —

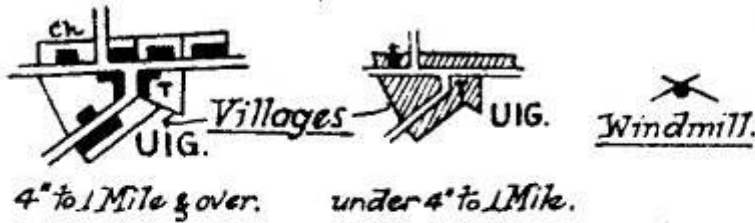

— Railways. —

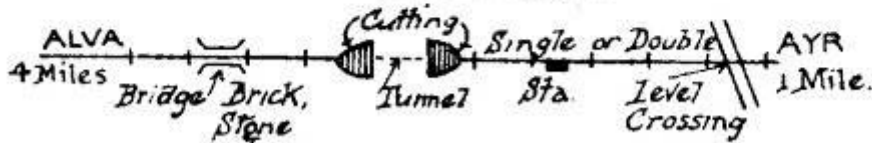

— Roads. —

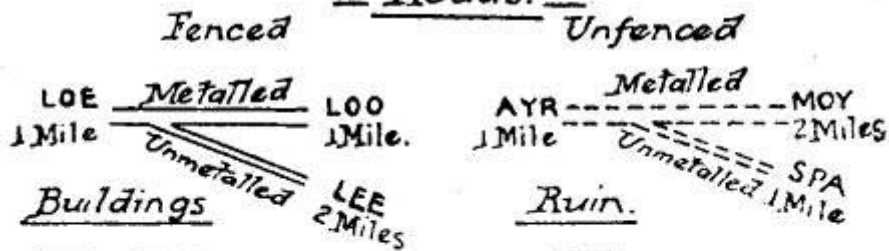

Buildings



Canal.

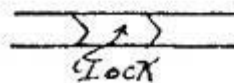

River.



Telegraph.

Tramways





**CONVENTIONAL SIGNS**







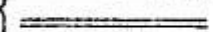





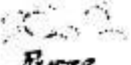

— used in the —

**ORDNANCE SURVEY.**

**6" MAPS.**

Railway, Double Line,   
 Railway, Single Line & Tramways,   
 Main Roads, Fenced  Unfenced.  
 Minor Roads, "  "  
 Contours— Red or Blue. { Instrumental, — 100 — } Black.  
 { Sketched, - - - 125 - - - }

**Woods.**

 Coniferous.  
 Deciduous.  
 Mixed.  
 Underwood.  
 Rough Pasture  
 Furze  
 Marsh  
 Reeds  
 Osiers  
 Sand Pit  
 Gravel Pit  
 Quarry  
 Shingle  
 Other Pits  
 Cutting,  Embankment,   
 Well, Spring, Boundary Post, o Pump, Guide Post,

**ABBREVIATIONS USED**

— in the —

**ORDNANCE SURVEY**

Bench Mark,	B.M.	Low Water Mark (1"),	L.W.M.
Bridle Road,	B.R.	" " (6"),	L.W.M.O.S.T.
Church,	Ch.	Mile Stone,	M.S.
Farm,	Fm.	Pump,	P.
Footbridge,	F.B.	Post Office, without Telegraph,	P.
Guidepost,	G.P.	" " with " "	T.
High Water Mark (1")	H.W.M.	" " " Telephone,	Pt.
" " " (6")	H.W.M.O.S.T.	School,	Sch.
Letter Box,	L.B.	Station,	Sta. STA.
Lamp Post,	L.P.	Well,	W.

Conventional Signs and Lettering used in  
Field Sketching.



- Road 1st Class.
- Main Road from town to town, 14 feet of metalling.
- Fenced.      Unfenced.
- RAILWAYS (1-inch maps).
- LETTER BOX      L.B.
- POST OFFICE, at Village P
- TELEGRAPH and POST OFFICE, at Village T
- FOOT BRIDGE      F.B.
- FOOT PATH      F.P.
- MILE STONE      M.S.
- MILE POST      M.P.
- STATION      Sta

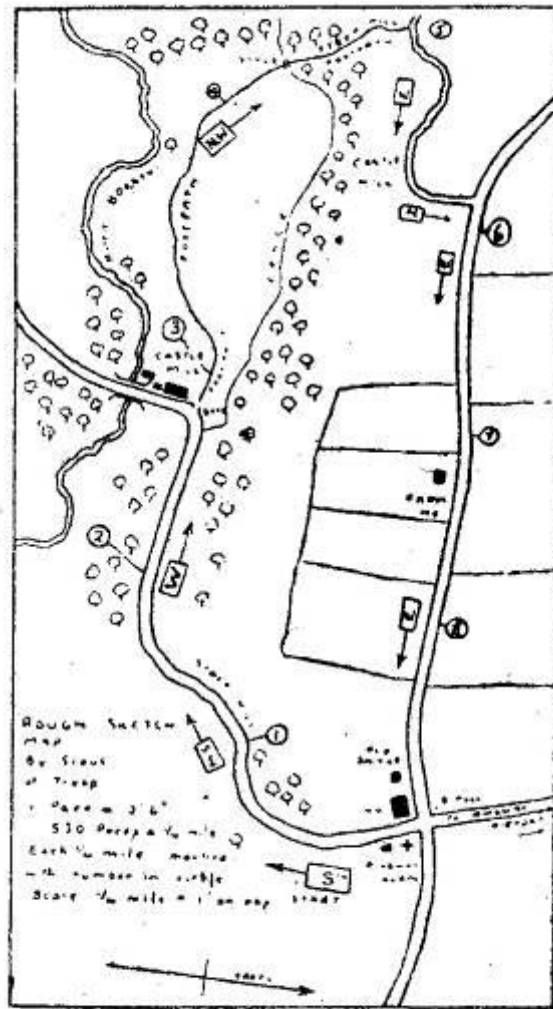

A Rough Field Sketch.

### LETTERING.

Lettering must be easily legible and should show clearly to what it refers.

*jkpqvxz.*

*An otherwise excellent Sketch or Map may be spoiled by bad lettering.*

*ffjqvz.*

*Lettering should be horizontal excepting the names of rivers, railways & canals. jkqw.*

The names of these should be written along their courses in the following types of printing called Blocks.

*jqvz.*

**SLOPING BLOCKS ARE EASIEST TO DO AS WELL AS BEING MOST EFFECTIVE.**

**HJQUXYZ.**

**1234567890.**

**UPRIGHT BLOCKS LOOK BETTER WHEN PRINTED SLOPING SLIGHTLY BACKWARDS.**

**FJMQVXZ.**

**1234567890.**

*The following are Italics Capitals :-*

*ABCDEFGHIJKLMN OPQRSTUVWXYZ.*

*ABCDEFGHIJKLMN OPQRSTUVWXYZ.*

*and should only be used as such.*

## CHAPTER II.

### HOW TO MAKE A SIMPLE MAP.

A MAP is a representation on a small scale of the features of the earth's surface. The *scale* to which a map is drawn is usually expressed as the ratio of a distance *on the map* to the corresponding distance on the earth's surface. The scale might be 1: 25,000,000 that is, 1 inch on the map would represent 25,000,000, inches or *about* 400 miles on the earth's surface. It is hardly likely that the average person will be concerned with mapping on such a scale! What is more probable is that in everyday life it might be necessary to make a careful *large scale* map to show just a few features of the countryside in great detail. The Ordnance Survey map of Great Britain is on a scale of 1: 63,360, or *1 inch to a mile*. Other scales used by the Ordnance Survey are 2 miles to an inch or 10 miles to an inch, and for very detailed work the scale is 25 inches to a mile. Even this last scale is not necessarily suitable for the making of simple sketch maps as is required by Scout mapping tests. The scale, whatever it may be, is obviously *most important* and the scale used *must always* be shown on the map or the map loses much of its meaning.

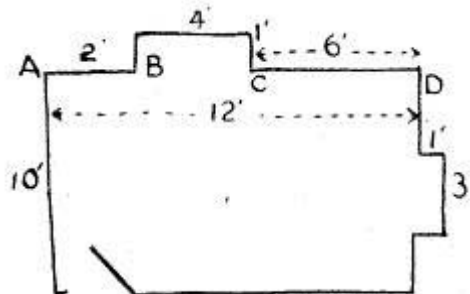

Fig 1.  
Rough Sketch.

In order to understand how maps are made it is desirable to do some *practical mapping*; that is, to practise putting on to paper the essential features of an area of land. As a first exercise it is suggested that a *plan of a room*, classroom or Scout headquarters should be made. This is a convenient area to use as measurements are comparatively easy to make – there is no reason why a ruler should not be used for an indoor dining room or a Scout staff for a larger Scout Headquarters. It is within the range of possibility that it might be necessary to purchase linoleum to cover completely such a floor space. If the linoleum to be used was an expensive one it would be desirable to know the *exact* measurements of the room in order that wastage might not occur. The easiest way to do this is to make a rough sketch on paper showing the shape of the room – the position of the door, fireplace, bay window or recess, etc., and then to add exact measurements to the rough sketch. The measurements may be made with the most convenient and handy measuring instrument. All measurements should be *checked* to reduce the possibility of *error*. Having done this it is a simple matter to make an accurate *plan* of the room to *scale*. If the length of the longest side of the room is 12 feet, then a suitable scale for transferring the main features of the room on to paper would be 1 inch (on paper) to 2 feet of the room. Near the bottom of the paper rule a line 6 inches long to represent the side of the room of length 12 feet. The presence of a recess on this side of the room would necessitate a slight modification being made. For the purpose of this first practice it could be *assumed* that all the angles of the room are right angles. The diagrams will help to make all this clear.

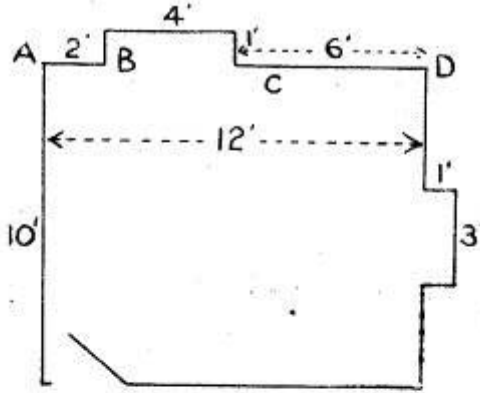

Fig 2.

Second Sketch, Proportions Correct, Ruled on Paper.

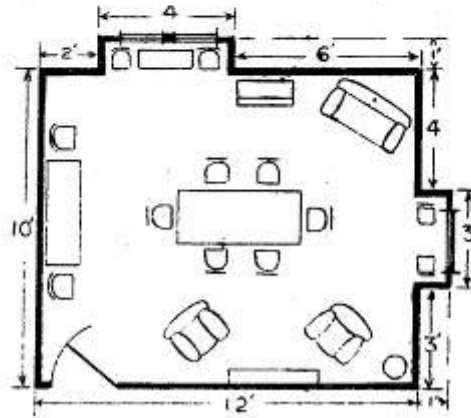

Fig 3.

Finished Plan of a Room.

**Map of a Small Area of Land.** – When finding the area of large tracts of land, a *Surveyor* uses a method known as *triangulation*. It is termed “triangulation”, because by means of an instrument called a *theodolite* he is able to divide the required area into *triangles* whose *angles* are known. A triangle is a three-sided figure whose angles add up to 180 degrees, that is, the equivalent of two right angles. By means of a Scout staff or, as is used by the Surveyor, a *chain*, it is possible to measure some of the sides of the triangles. If the angles and some of the sides are known it is possible to calculate the *area* of the triangle. Great accuracy is necessary and there must be a line, a *base line*, on which the triangles can be built. One such base line was made by the Ordnance Survey on Salisbury Plain when finding the area of the British Isles.

**Method. – Area of a Playing Field.** – 1. Make a rough plan of the field as seen from the top of the pavilion.

At A, as near to the boundary as possible, drive in a Scout staff preferably with a Patrol flag attached to the top to assist with sighting. Measure the distance AB as accurately as possible, making use of a Scout staff, a steel tape if one is possessed, or a length of knotting cord of known length, e.g. 10 yards. In the same way measure BC, CD, DE, EF, FA. It is necessary, however, to know certain other lengths, namely, AC and AE. Between these points there are no well defined boundaries, *i.e.* they are imaginary lines running across the playing-

field. It is therefore necessary to drive Scout staves into the ground in such a manner that poles at, e.g. X, Y and Z are in a straight line with each other and with A and C. The distance between these poles is then measured, the total being the length of AC. Obviously the distance between any two poles must be less than the length of, e.g. the cord which is being used for making measurements in order that that cord may still be used with accuracy. All these measurements should then be entered on to the *rough plan*.

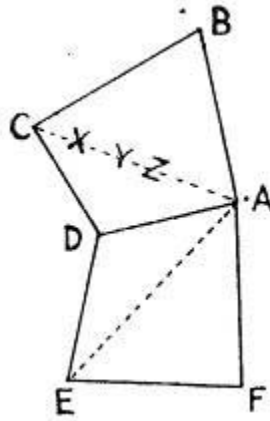

With the aid of compasses and a good ruler it is easy to make a *scale* drawing of the area. (See also page 20.) The actual area may then be calculated by using squared paper. A tracing of the area surveyed is transferred to squared paper. The number of whole squares enclosed by the boundary line is counted, ignoring squares *less than half* but counting as whole squares those greater than half. Half squares are counted as such. The area represented by one of the small squares must be calculated, using the scale of the plan. The area represented by the total number of squares may then be calculated.

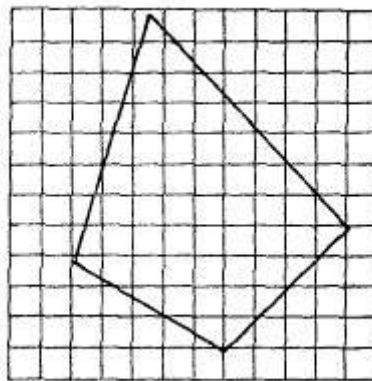

**Second Suggestion – The Ray Method.** – (A. W. N. Mackenzie.)

*Apparatus.* – Paper, pencil, Scout staves, compass, a flat board and a ruler.

*Method.* – Make a rough survey of the land to be mapped by walking over it. Choose the longest line with an unobstructed view as the *base line* for the map. Drive in a staff at one end of this line. Proceed to the other end of the base line.

Fasten the paper to the board by means of drawing pins. If possible, fix the board to a tripod so as to make a *plane table*.

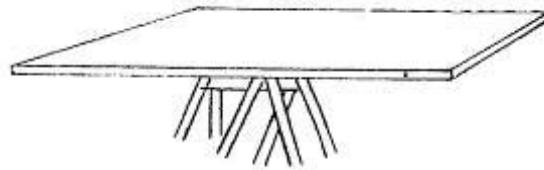

PLANE TABLE

Arrange the board so that the greatest length of the paper is facing in the direction of the staff at the other end of the base line. Select a point X on the paper and stick a pin there to represent the spot where the board is set up. Determine the position of the true north and indicate its direction on the map in, e.g. one corner. Place a compass on the true north line and draw the magnetic north line as indicated by the compass. The purpose of this is to enable the board to be set in the same relative position when it is removed, at a later stage in the mapping, to the other end of the base line.

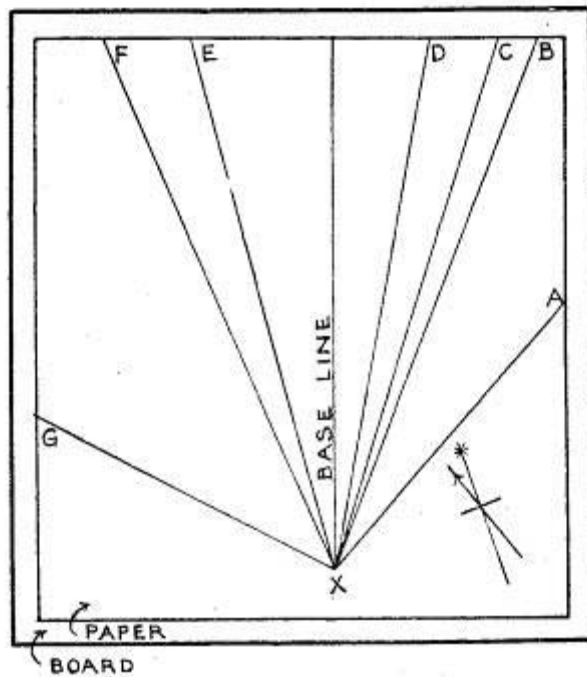
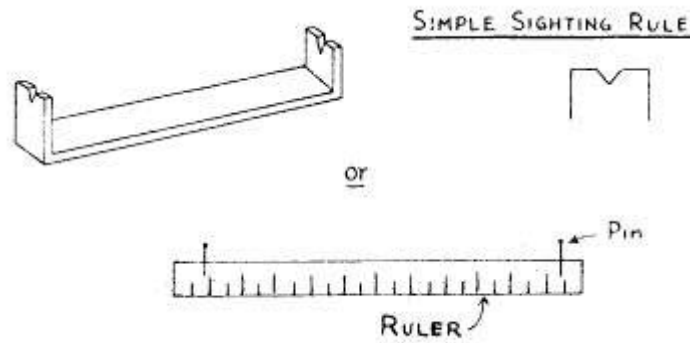

Diagram 1.—Showing the Sketching Board set up in its first position.



Place the ruler on the board with the edge against the pin at *X* and *take a ray* to the staff at the other end of the base line, i.e. adjust the ruler so that its edge points directly at the staff. If the base line is a long one the addition of a Patrol flag to the staff will assist. Rule a line on the paper in the direction of the staff and label it *base line*.

Next choose conspicuous objects not too far away such as edges of fences, corners of buildings, or trees, etc., and using the ruler as before take a ray to each of them in turn and rule *faint* lines on the paper in their directions as *XA, XB, XC*, etc. (See Diagram 1.).

Remove the board and the tripod and erect a staff at the spot where the board has been. Measure the distance from *X* to the other end of the base line using any apparatus available, or pacing the distance roughly followed by a check. Remove the staff at the end of the base line and set up the board there.

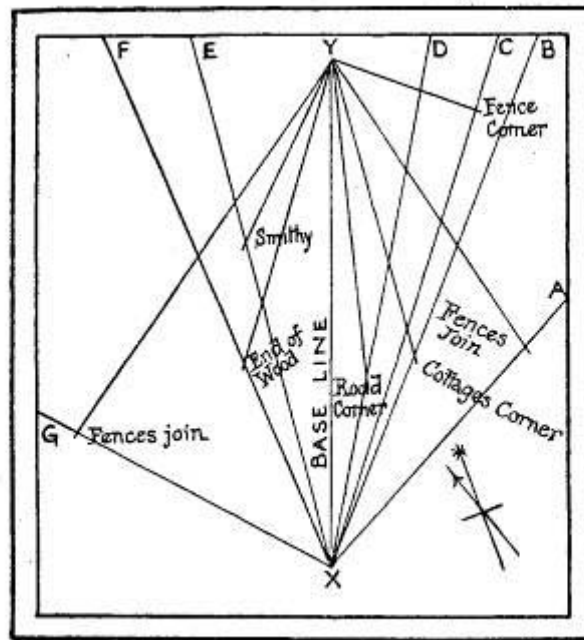

Diagram 2.—Showing the Sketching Board set up in its second position.

From *X* measure off the length of the base line to a scale of 6 inches to the mile, calling the other end of the base line *Y*. Remove the pin at *X* and fix it at *Y*. Place the ruler along the line *YX* and turn the board round until the ruler is pointing directly at the staff at *X*. Place the compass on the magnetic north line already drawn on the map, and if the compass corresponds with it then the board is correctly set.

With the edge of the ruler against the pin at *Y* take rays to each of the objects previously selected from *X*, and draw *faint* lines which will cut the lines *XA, XB, XC*, etc. The points where the lines cross will indicate the exact positions of these objects which should now be distinctly marked and named. (Diagram 2.)

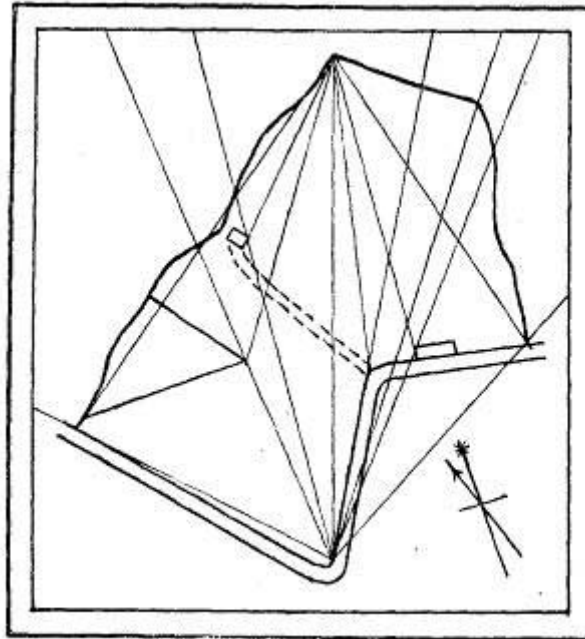

Diagram 3.—Illustrating the Addition of Detail.

Details of the ground, such as roads, streams, fences, woods, etc., should now be sketched in either by pacing or measuring to them from the prominent objects in the directions indicated by the compass, or if great accuracy is not essential, by *estimating* their positions and distances by eye. (Diagram 3: to prevent confusion the lettering shown in Diagrams 1 and 2 is omitted in Diagram 3.)

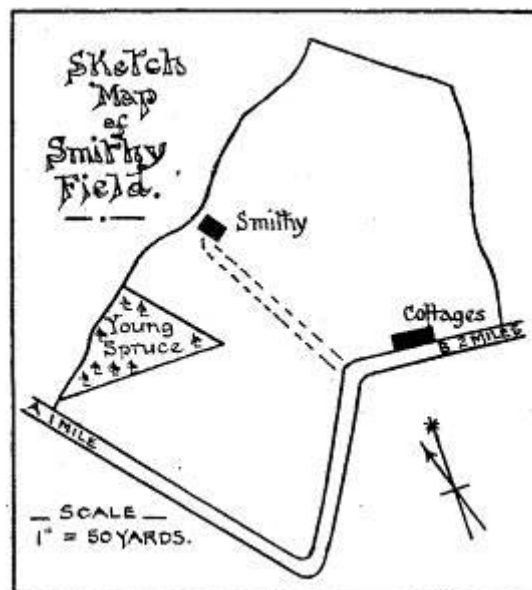
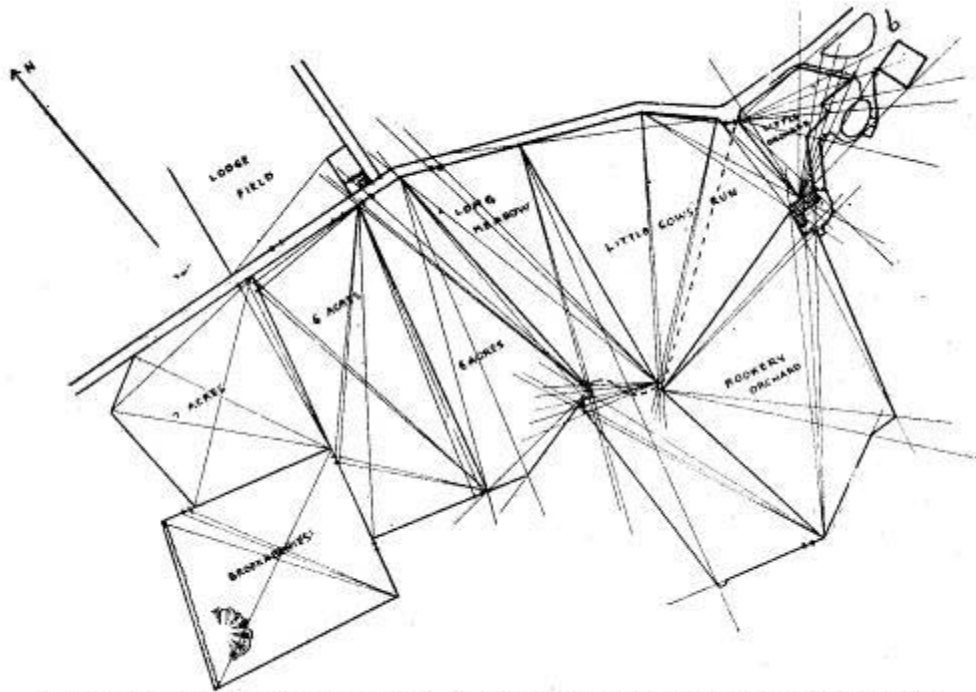
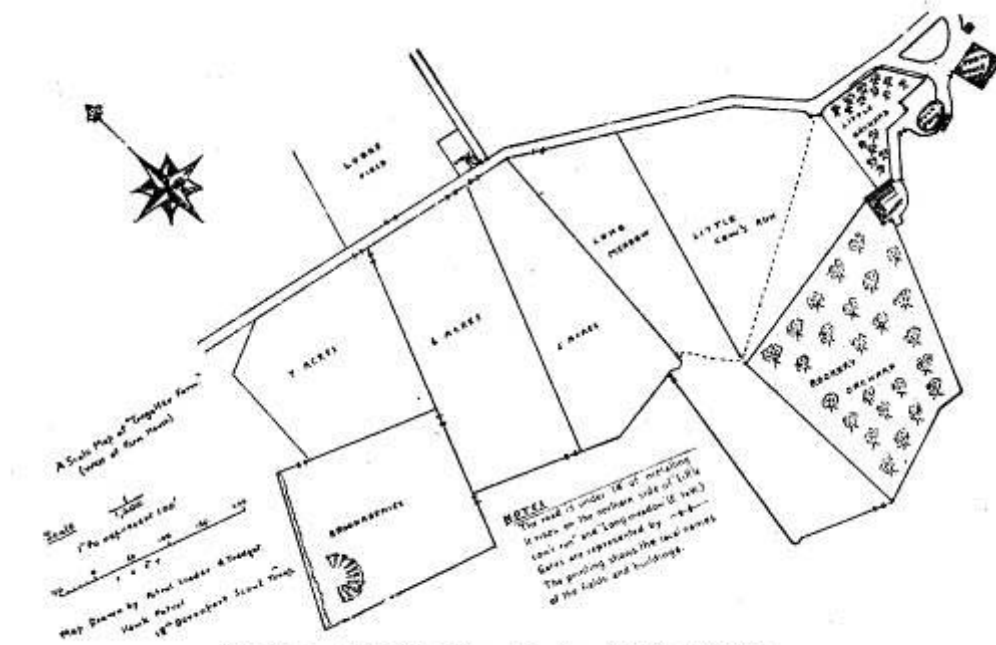

Diagram 4.—The Completed Sketch Map.

Ink in the details of the sketch map; show the SCALE and the NORTH POINT clearly; give the map a TITLE; rub out all pencil marks. (Diagram 4.)



Map of a Cornish Farm by P/L A. Tredget, 18th Devonport, showing Position of " Rays".



P/L Tredget's finished Map of a Cornish Farm (1940).

*Special Note.* – By drawing to a smaller scale more distant objects can be shown on the paper. After reaching the stage indicated by Diagram 2 the board may be removed and fixed at one of the prominent objects, the exact position of which has been ascertained. The board should be *set* by sighting back to X or Y or both and its setting should be checked by the compass. A further series of rays may then be taken to more distant objects and their positions fixed by moving the board to another of the prominent objects and taking rays to the same

distant objects as previously explained. This method is satisfactory for use by one person, e.g. an individual Scout preparing a sketch map for one of the Scout badges.

To repeat – triangulation is a method used for the making of maps using a triangle as a basis. If the length of one side of a triangle is known and two of its angles then it is possible to find the length of the other two sides. If in a triangle  $ABC$  the length  $AB$  is known and the angles  $CAB$  and  $CBA$ , then it is possible to find the length of the other two sides. On a large scale the length  $AB$  may be 250 yards.  $A$  might represent one corner of a field,  $B$  a cattle trough and  $C$  a cowshed some distance away.

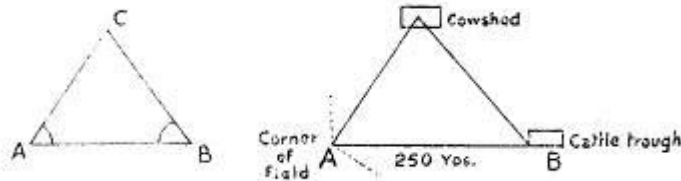

In actual practice the big difficulty is one of ACCURACY: how to measure *accurately* the angles  $CAB$  and  $CBA$ . To ensure accuracy when mapping on a large scale a *Surveyor* uses an expensive instrument called a *theodolite*. This is not unlike a telescope fixed on to a base board with an angle scale attached. If the theodolite was at  $A$  it might be sighted on point  $B$ . The scale on the board would then be set at 0 degrees and the theodolite swung round until it pointed at  $C$  and the number of degrees traversed would be noted. A real theodolite is an unessential instrument as far as Scouts are concerned as there are ways of constructing simple instruments which give reasonable accuracy.

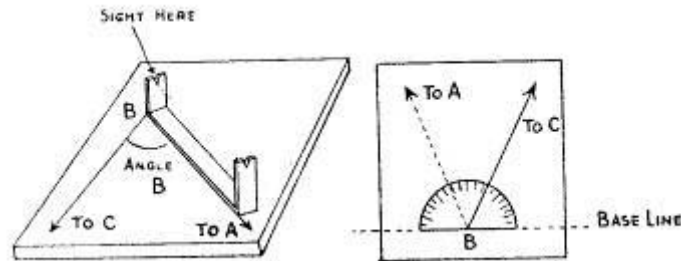

Refer back to the diagram of the playing field. In the “angle” method the side  $AE$  would be measured as in Method 1, and its direction obtained using a simple plane table, a sighting rule and Scout staves. If possible, make the plane table perfectly level by using a spirit-level. Place the sighting rule on the table as shown in the diagram so that the sights are in exactly the same straight line as the Scout staves. Draw a line on the paper on the plane table to show this direction. The direction  $BC$  is obtained in a similar manner and the angle  $B$  is noted. The angles at  $A$ ,  $F$ ,  $E$ ,  $D$  and  $C$  should be obtained in the same way. It is also desirable to obtain the angles  $BCA$ ,  $FAE$ , etc. The various distances  $BC$ ,  $CD$ , etc., may be obtained as in the first method. All that remains to be done is to make a scale drawing of the area under survey.

## CHAPTER III.

### HOW TO ENLARGE OR REDUCE A SIMPLE SKETCH MAP.

It may be necessary to enlarge or reduce maps and plans for some particular purpose. This may be conveniently done in a simple yet accurate way, provided that due care is taken, by means of *squares*. One or two examples not necessarily to do with mapping may be helpful. It may be necessary to enlarge an illustration of the Scout Tenderfoot badge perhaps for display purposes or in connection with the making of a calendar. Obtain a print of the Scout badge, e.g. from the cover of *The Scout*. Mount this on a piece of paper and then draw a square round the badge as shown in the diagram. Divide up this square into a suitable number of small squares. Take a second sheet of paper and rule on it a square which is five, ten or twenty or more times the size of the original print of the badge. Divide this into the same number of squares as the original. It is now quite a simple matter to draw in the enlarged outline of the badge by noting where the horizontal and vertical lines cut the badge outline. For a symmetrical design of this sort, only half the badge need be drawn in this way, as by means of thin tracing paper it is possible to make a tracing of one side of the badge for use in drawing the other half.

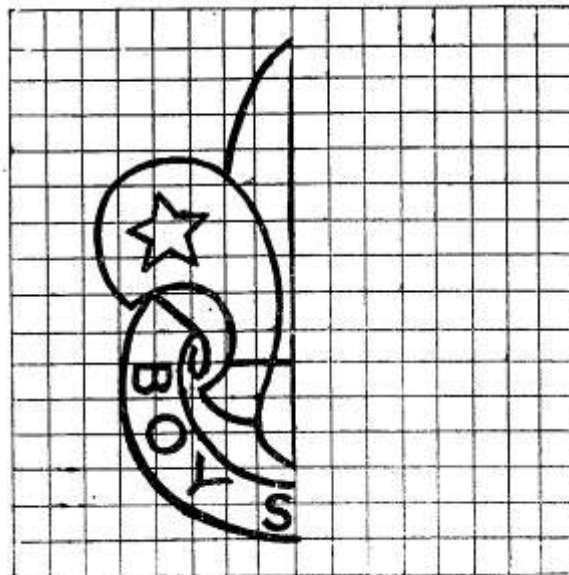
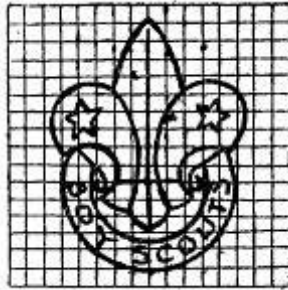

The Scout handyman may like to make a cut-out of his Patrol emblem for use in the "Patrol Den" or a stencil for marking the Patrol gear. If a small illustration of the Patrol emblem is available, e.g. in *Scouting for Boys*, then an enlarged copy may be made as in the previous method. The illustration will help to make this clear.

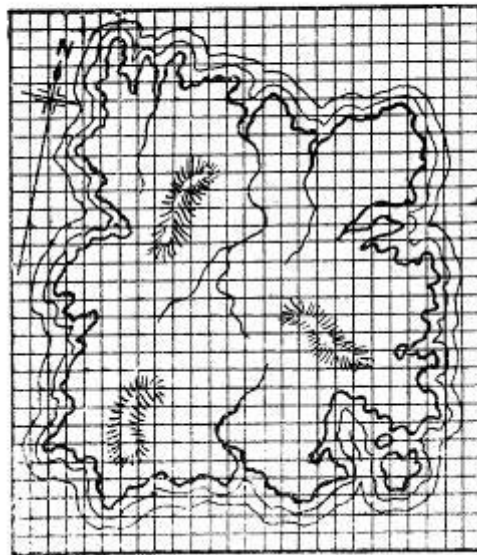
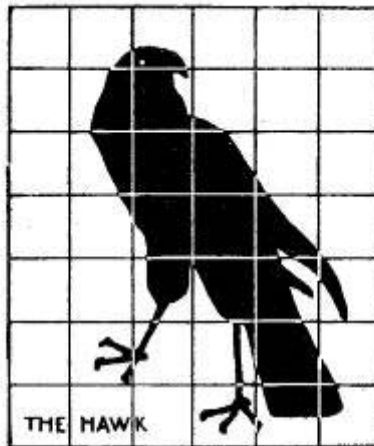

Treasure Island.

Here is something a little more elaborate which I have adapted from a stunt which appeared some years ago in *The Scout*. In *The Scout* a suggestion was made for raising money at the “Troop Parents’ Evening”. It was suggested that an imaginary “Treasure Island” should be sketched on paper divided into squares as in the illustration. Parents were invited to stick a flag in one of the squares paying a small sum of money for the privilege.

Either some secret sign was made underneath a particular square on the map to represent “treasure” before the map was pinned up or the location of the “treasure” square was handed to a member of the Parents’ Committee. At the end of the evening the successful treasure seeker’s name was announced. An improvement on this – for at the same time an important piece of Scouting is demonstrated is to get the parents to enlarge the map of “Treasure Island” by filling in the map outline for any one square and numbering it. The “treasure” is located somewhere along the map outline or on some line shown on the map. A Scout or Scouts must explain to the parents the two ideas of the stunt.

Parents must be warned that they must make an exact outline in their allotted square or they may miss the treasure.

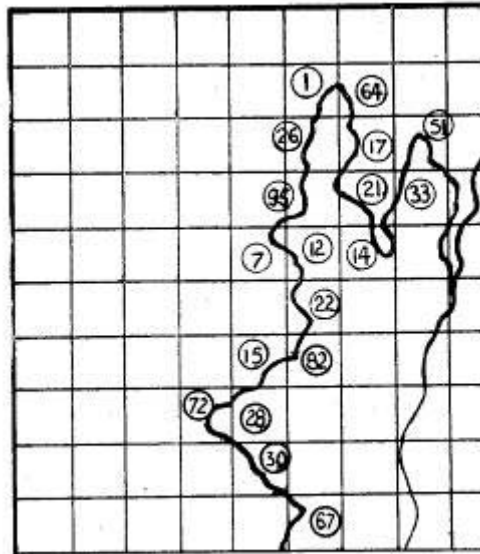

Treasure Island Map as Enlarged by Parents.

Now to apply the same sort of thing to maps or plans. The map or portion of the map (A) to be enlarged is divided into squares of suitable size and the clean sheet of paper on which the enlargement is to be made is divided into squares (B), the sides of which bear the required ratio to the sides of the squares on the original. The various marks contained in the squares in (A) must be carefully measured and reproduced in their relative positions in the corresponding squares in (B). The same system *reversed* is used for the *reduction* of maps and plans.

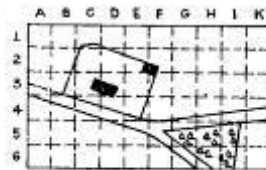

Original A.

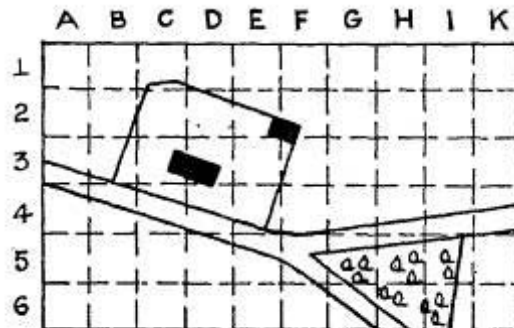

Enlargement B.

## CHAPTER IV.

### THE TRUE NORTH AND THE MAGNETIC NORTH.

THE north is the universal direction which is shown on maps and from it all other directions can be found. It is most important that the relationship between the ground represented on the map and the compass directions be given. On the Ordnance Survey maps the left and right hand edges of the map point *true* north and south, the top towards the north. Scouts should be careful to see that any sketch map prepared in connection with badge tests clearly shows the direction of the true north. The word “true” is necessary because the needle of the *compass* does not point to the geographical or true north but to the *magnetic north*. Essentially a compass consists of a magnetised needle pivoted in such a way that it is able to swing freely. The fact that the compass needle does not point to the true north but to the magnetic north is true of all places on the earth’s surface except at places situated along an irregular line called the *line of no variation*, which circles the earth approximately north and south. The difference or angle between the magnetic and the true north at any spot is called the *magnetic variation*.

This “line of variation” does not remain stationary but is always swinging very slowly east or west. It is therefore either approaching or moving away from any spot on the earth. Consequently the magnetic variation at any spot on the earth’s surface must similarly be diminishing or increasing. This increase or decrease in the magnetic variation for each year is called the “annual change”. True and magnetic north are shown on the 1 inch to the mile Ordnance Survey coloured map as shown in the following diagram: –



If the local magnetic variation and the annual change are stated on a map the approximate variation for any future year may be calculated as follows: – Supposing the map shows “magnetic variation 18° 36’ W. 1914; annual decrease 6’ ” – the variation for 1923 will be  $(18^{\circ} 36') - (6' \times 9 \text{ years})$  degrees = “18° 36’ – 54’” = 17° 42’ W. (If the annual change had been shown as 6’ increase it would of course be necessary to add 54’ to 18° 36’ W.

In addition to magnetic variation the compass is liable to be affected by what is known as *magnetic deviation*. This is caused by metallic attraction in, or on, the earth in the vicinity of the compass. In large towns attractions are numerous, such as gas and water mains, railings, etc. On board a ship special precautions have to be taken in this connection. As this attraction cannot be calculated or allowed for great care must be taken before reading the compass to see that all metallic substances are removed from the immediate vicinity, e.g. penknives.

**How to Show the True and Magnetic North in Making a Map.** – Owing to the near presence of metallic substances it is very unlikely that the compass being used by a Scout who is map-making will give the correct magnetic north so that the true north would be correspondingly wrong. The true north is a direction which *never* alters – therefore the true north should be used as the basic one for the map,

If a map is being made and a drawing board is available, fix the drawing board in position and draw in the base line for the map. Take a watch and lay it near the edge of the sheet and point the hour hand to the sun. Half way between the hour hand and 12 o’clock (1 p.m. Summer Time) will then be *south*. South of the equator this would of course be north. Draw this line



marking the end of it away from the sun in some conspicuous way. To draw this line accurately hold a blade of grass vertically so that its shadow is thrown across the watch face and then bring the hour hand into this shadow. Even if the sun is not clearly visible it will be found that an object always casts a shadow no matter how dark the day. Having fixed the drawing board and drawn in the base line, hold the blade of a pocket-knife vertically with the point near the edge of the paper and revolve the knife until the blade casts a narrow black shadow. Draw this line faintly on the paper, point the hour hand of the watch along it and proceed as above.

After removing metallic objects from the neighbourhood of the drawing board lay the compass over the true north line, and when the needle comes to rest make marks on the paper opposite both ends of the needle. Draw an arrowhead at the north end of this line which is the magnetic north as indicated by the compass. The angle between the magnetic north and the true north gives the variation of the compass for that year.

### **Setting the Map.**

1. *With a Compass.* – If the magnetic north line is shown on a map, place the compass exactly over the magnetic north line (continued if necessary) and turn the map round slowly until the needle of the compass at rest and the magnetic north line coincide – the map is then set. If the magnetic north line is not shown on the map, this line can be drawn in with a protractor from the variation which is indicated in the margin of the map. About 17 degrees west is a fair average for magnetic variation in Great Britain. The compass is placed on this line – proceed as already described.

2. *Without a Compass.* – Identify on the map the exact spot where you are standing and make a mark.

Pick out an easily distinguished object on the map. Lay a straight-edge along the line of the mark and the representation of the object chosen. Turn the map slowly round until the mark, the representation of the object and the object itself are in the same straight line – the map is then set.

3. *To Find on a Map the Spot where the Observer is standing.* – If two prominent points on the map CAN be recognised, take a compass bearing on each of these points and draw lines back from them on the map. The point of intersection represents the spot at which the observer is standing.

## CHAPTER V.

### SCALES.

NOTE. – To avoid confusion it is necessary to remember that in talking of *scales* with reference to maps the word is used in two different senses. There is the *scale* to which a map is drawn (such as 1 inch to 1 mile) and there is also the *scale*, which is usually shown in the margin from which distances on a map are measured.

**A SCALE indicates the proportion which the distance between any two points on a map bears to the horizontal distance between the same two points on the ground.**

Thus if the distance between two points on a map is 4 inches and the horizontal distance on the ground between the same two points is one mile, the scale is 4 inches to the mile.

The scale is usually shown in the margin of a map or immediately beneath the heading and from it distances on the map are measured. Generally speaking it should be from 4 to 6 inches long, excepting on very large maps when the scale should be longer as it will then probably be necessary to measure much longer lines.

When no scale is indicated or drawn a map is practically useless as then one is unable to ascertain the distances between points.

### REPRESENTATION OF SCALES.

A scale may be represented by merely stating it as:

**Scale=4 inches to the mile.**

or it may be shown thus: –

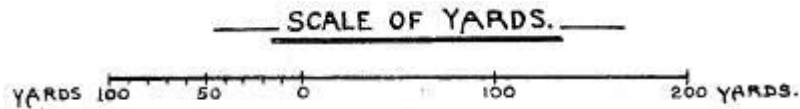

which shows yards; or thus: –

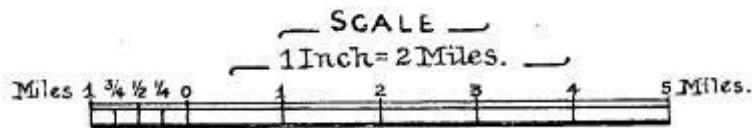

which shows miles, or by a representative fraction (R.F.) thus: —

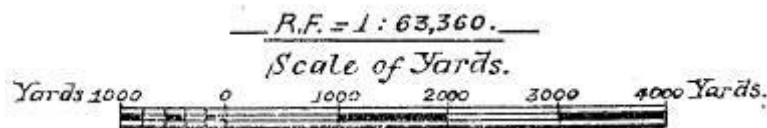

which means that each unit on the map represents (in this case) 63,360 similar units on the ground; or by an R.F. stated in multiples of 10 (as shown in the 12500 O.S. map and on foreign and some colonial maps) thus: –

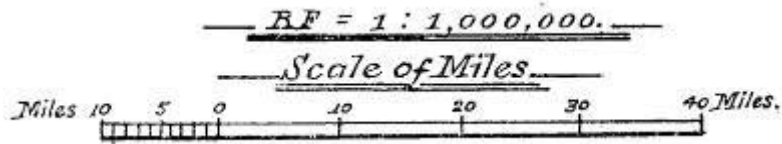

When the scale is stated in multiples of 10 to find the number of miles to the inch, divide the denominator of the R.F. by 63,360 (the number of inches in a mile).

Supposing the R.F. to be 1: 100,000, then the number of miles to the inch is  $100,000/63,360 = 1.58$  miles to the inch.

To find the number of inches to the mile when the R.F. is stated in multiples of 10, divide 63,360 by the denominator of the R.F.

Supposing the R.F. to be again 1: 100,000, then the number of inches to the mile is  $63,360/100,000 = 0.63$  inches to the mile.

### **DIVISION AND SUBDIVISION OF SCALES.**

As has already been stated a scale is shown on a map so that distances on that map may be measured.

**A scale is divided according to the unit of measure that is required.** That is to say, if it is desired to measure a small scale map in miles it would be ridiculous to divide the scale into feet: if it is desired to measure in feet it would be equally ridiculous to divide the scale into links.

**In order to be able to measure smaller distances, the left division of a scale is subdivided into smaller divisions which must be parts of the larger divisions.** That is to say, if the scale shows hundreds the left division must show parts of a hundred; if miles, parts of a mile; if chains, parts of a chain; if tens of miles, parts of 10 miles, and so on. This is illustrated in Diagrams H and I where H shows correct and I incorrect subdivision.

A moment's thought will tell the reader that when the nothing or zero point of a scale is shown at the extreme left hand end it is not so easy to get direct accurate measurements as when the zero point is shown at the right of the left division. (See first Scale in Diagram I.)

**Always, therefore, show the zero point at the right hand end of the left division and subdivide it from right to left.**

### **CONSTRUCTION OF SCALES.**

Suppose a map is to be drawn to the scale of 2 inches to the mile. To construct the scale: –

As already stated, the scale should be from 4 to 6 inches long.

It will be found most convenient (in this case) to divide the scale into thousands of yards.

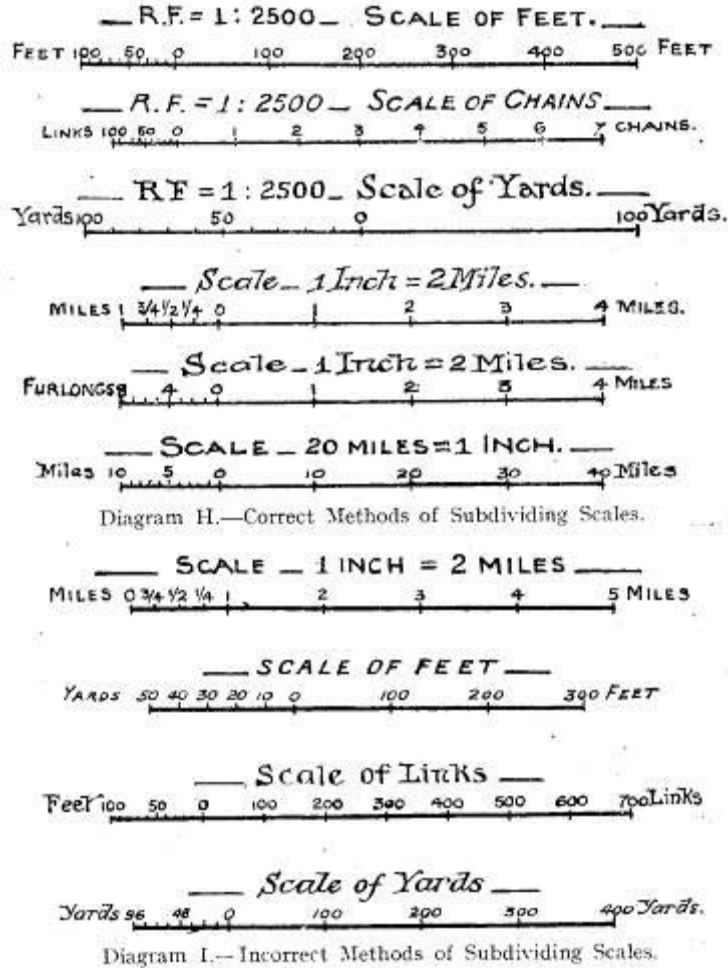

It is known that 1760 yards is represented by 2 inches. Therefore 4000 yards will be represented by  $\frac{2 \times 4000}{1760} = 4.54$  inches.

1760

Draw a line 4.54 inches long and from one end of it draw in pencil a line (X) at about 45° and mark off from this end four equal units – say inches. (See Diagram.)

Join the fourth unit to the end of the scale line and draw parallels from the intermediate units to cut this line.

The scale is now divided into sections of 1000 yards,

Now to subdivide the left division into parts of 1000 yards.

Suppose it is decided to subdivide in hundreds of yards.

From the left end of the scale line draw a line (Y) on the opposite side from (X) and mark it off into 10 equal units.

Join the tenth unit to the right end of the left division and draw parallels from the intermediate units to cut the scale line. (See Diagram.)

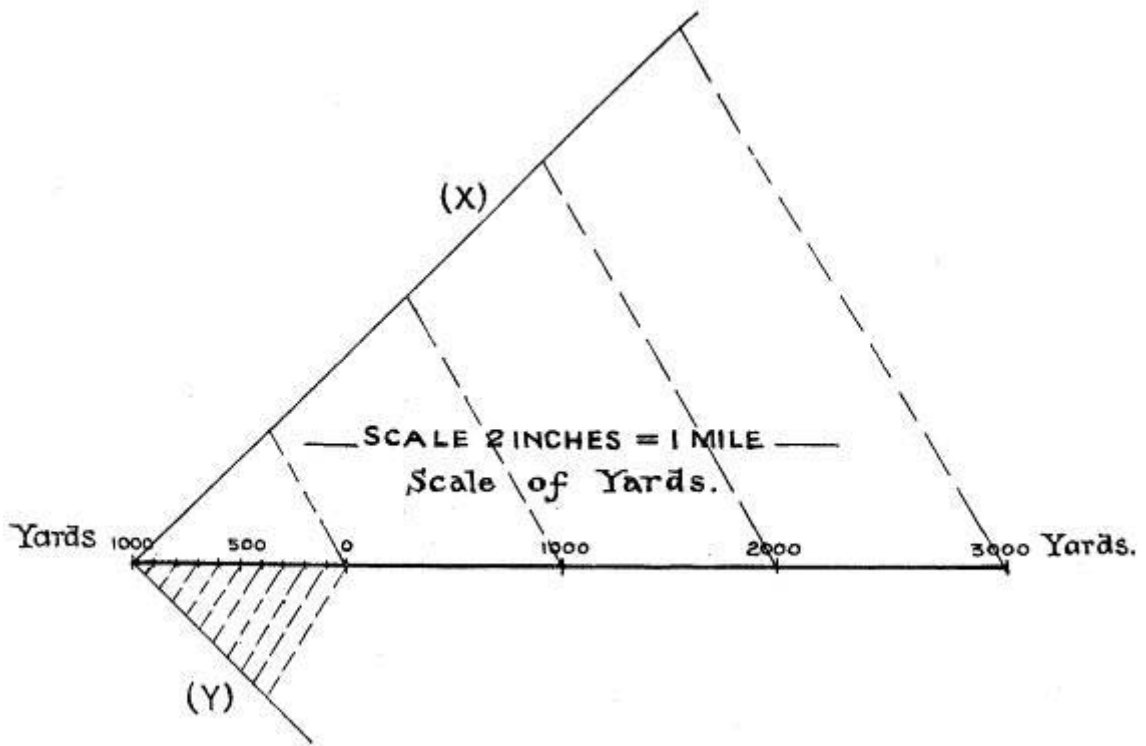

## CHAPTER VI.

### SCOUT ESTIMATION TESTS.

ALL Scouts should be able to *estimate* (not guess) such things as heights, distances and numbers with reasonable accuracy. Imperial Headquarters are kind and allow a big margin of error – 25 per cent, *either way for the* purposes of the Scout estimation tests, which means to say that if there are 100 people in a room and a Scout estimates that there are between 75 and 125 he complies with the regulations. It is, of course, the aim of every Scout to get much nearer the correct number or height or distance by *careful estimation*. Scout regulations do not allow apparatus to be used during the actual test, so that the only way a Scout can become accustomed to estimating with accuracy is to *check* each practice estimation which he makes. Such checks may involve actual measuring or the use of simple apparatus. Estimations made in the field are most useful as aids to accurate sketch-map making.

Every Scout should be his own “rule”; or, in other words, he ought to know his own personal measurements. The origin of apparatus for measuring probably takes us back to the time of primitive man. Our savage ancestors soon came to realise the value of living in *communities* for mutual protection, often living in caves. It was only natural that the work necessary to maintain the life of the community should be shared amongst its members. Some would be hunters, others agriculturalists, whilst others did “cave” duties. We may imagine that when arts and crafts developed one member of the community would specialise in making leather thongs which he would trade to other members of the community for meat and other food. Naturally the length of thong would depend upon the nature of the goods offered in exchange, and so no doubt arose the idea of measuring lengths by stretching the leather from the chest to the finger-tips, a method still of practical use. Obviously, to prevent quarrelling, it would soon become necessary to establish *standard* lengths, possibly a branch of a tree would be used for this purpose.

Our modern standard measures of distance probably arose in some such way as this. It is very interesting to note that all the early standards of measuring had something to do with man’s work – the mile a thousand Roman paces (each pace two steps); a team of oxen could pull a plough a “furrow-long” (furlong) before resting: the pole used for prodding the oxen gave its name to the poles. In the Old Testament we read of the “cubit” and the “span” – the cubit varied in length from 18 to 22 inches, in different countries, while the span represented the distance from the end of the thumb to the end of the little finger when the fingers are extended. In this country, as history books show, the “ell”, a unit of length used in connection with the sale of cloth, was the length of a man’s arm from the shoulder to his fingertips (about 1¼ yds.). To-day the standard yard is the distance between two marks on a metal bar kept in the offices of the Board of Trade in London. This bar is of bronze and the distance between the marks must be measured at 60 degrees Fahrenheit, which is the temperature at which Government offices are usually kept.

A Scout can easily have his own standards of measuring if he adopts the following suggestion, which is that a personal measurement table should be completed on a small piece of cardboard which will easily fit into a pocket or the chart in a *Boy Scout Diary* (*Brown’s* is the best) can be filled in. Incidentally this card must be kept up-to-date as a Scout is a rapidly growing young animal!

1. The Scout’s own height. (Stand against things to estimate height.)
2. The span of thumb and forefinger – for measuring short distances.
3. The span of thumb and little finger.

4. Distance from finger-tip to finger-tip when the arms are fully extended sideways – this is approximately equal to the Scout's height and is valuable for measuring short distances above ground level.
5. Length of ordinary pace – useful for measuring distances. Take the *average* length of pace.
6. Length of nail joint of forefinger – this is approximately one inch in an adult.

Others are shown in the illustration below which is taken from *Brown's Boy Scout Diary*, price 1/-.

**Handy Self Measures.** – Every Scout should know his personal measurements.

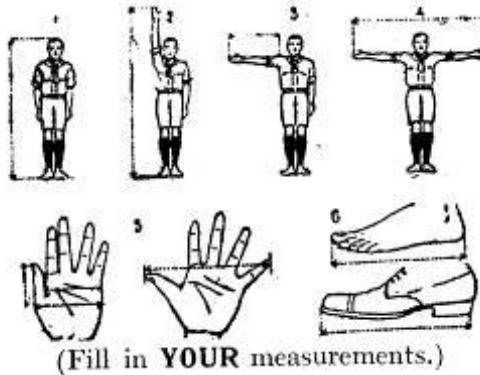

1. Height \_\_\_\_\_
  2. Height to tip of extended hand \_\_\_\_\_
  3. Length of arm, armpit to tip of finger \_\_\_\_\_
  4. Extended arms, finger-tip to finger-tip \_\_\_\_\_  
(Called a fathom and nearly equals your height.)
  5. Hand. Length of thumb \_\_\_\_\_  
Breadth of hand \_\_\_\_\_  
Breadth of hand, thumb to small finger \_\_\_\_\_  
(This is the hand measurement used in measuring horses.)  
Span of thumb to little finger \_\_\_\_\_
  6. Length of bare foot \_\_\_\_\_  
Length of boot \_\_\_\_\_
- also: –  
Wrist to elbow \_\_\_\_\_  
(This also gives you the length of the foot.)  
Elbows to tip of forefinger \_\_\_\_\_  
(Called a "cubit.")

Then again, no Scout is completely equipped unless he has a Scout staff – this is purposely and conveniently marked off in rings so that it may be used for measuring inches or feet. Incidentally, as all keen Scouts are readers of *The Scout*, published by Imperial Headquarters (Editor, F. Haydn Dimmock), they have at their disposal a handy 10-inch rule – this is to be found on the back cover of the paper.

Having established some "personal standards", the next thing to do is to get impressions of certain well-known-distances and heights, etc. A cricket pitch is 22 yds. between the stumps, whilst an Association football pitch is 120 yds. x 80 yds. Measure the height of the lamp-posts in your street or the width of the pavement outside your house, and then use these as standards so that estimations of longer lengths or greater widths may be made with a fair

degree of accuracy. It cannot be too strongly emphasised that to be skilled at estimations it is necessary to PRACTISE constantly. Once good standards are known then it is a comparatively easy matter to measure the unknown against the known, mentally, before deciding on a final estimate.

Now to take each type of test in turn and to explain methods of checking the estimation.

**Numbers.** – The rule is “start small” – in other words, don’t start by attempting to estimate the number of people at the local cup-tie. Start with a small number, *e.g.* TEN – tram tickets, marbles on a tray, lead shot in a bottle or leaves on a twig. Next try another “standard” – TWENTY of something or other: people in a photograph, sticks in a bundle, matches in a box or dots on a piece of paper. Once these “units” are firmly fixed in the mind then it is possible to estimate the number of people at the Troop concert by regarding the audience as being divided into so many of these units, When practising, a check should whenever possible be made by actual counting – but don’t do like the farmer is supposed to have done, count the number of legs and divide by four to find the number of cows in a field!

**Distances.** – It has already been suggested that certain “standard” distances should be learnt – mentally visualised for comparative purposes. Obviously for long distances it is wiser to use a map if one is available. As an exercise, when on a hill, study a map of the area, look at the scale and then try to work out the distance of a certain church or tower. This can be checked in a practical way by using the “Scout’s Pace” method, *i.e.* another Scout “standard” is that he can cover a certain distance in a certain time at “Scout’s Pace.”

1. *Estimating Widths.* – To measure the width of a river it is usual to select a prominent mark such as a bush near the water’s edge on the other side of the river and at a spot where the course of the river is approximately straight *X*. Place a stone at point *A* exactly opposite *X*. Pace off a convenient distance from *A* along the bank to *B* and place another stone. Continue to *C* making *BC* equal to *AB*. At *C* walk inland at right angles to the river bank until a point is reached where *D*, *B* and *X* are all in line. Place a stone at this point. *DC* represents the width of the river and may be measured again by means of a Scout staff. *AXB* and *BCD* are similar triangles, *BC* has been made equal to *AB*, *DCB* and *XAB* are right angles, *etc.*, and so *CD* is equal to *AX* and *CD* can be measured. The diagram will help to make this clear.

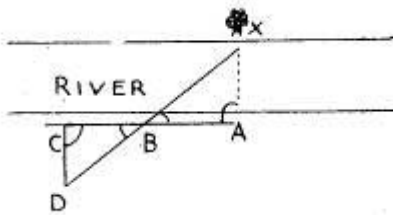

2. *Napoleon’s Method.* – It is said that Napoleon used this method for finding the distance of an unapproachable object. Study the diagram carefully. Stand on the bank of the river looking across the river, holding the chin with one hand to ensure that the eyes remain at the same level all the time the observations are being made. With the other hand, tilt the brim of the hat forward until it just cuts the opposite bank. Turn in any direction in which the ground is level and note the spot where the tilted hat brim appears to cut the ground. The distance from the observer to that spot is the approximate width of the river.



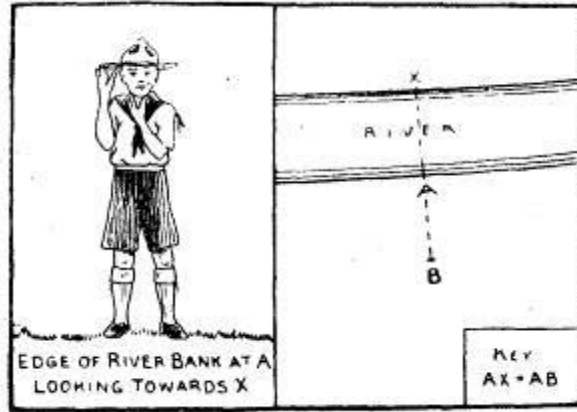

For these and other methods it is handy to be able to lay off a RIGHT ANGLE. If a compass is not available the following method may be used. Assuming that a right angle is to be made as at  $ABE$ . Take a cord and make a loop at each end and one exactly in the middle as shown. Put one loop over a peg at  $B$ ; drive in another peg anywhere on the line  $AB$  at  $C$  and put the other loop over that. Pull at the centre loop until both sides of the cord are tight and drive a peg through the centre loop at  $D$ . Remove the loop at  $B$  and pull it round until it is exactly in line with those at  $C$  and  $D$ . Drive a peg through the loop at  $E$ :  $BE$  is therefore at right angles to  $AB$ .

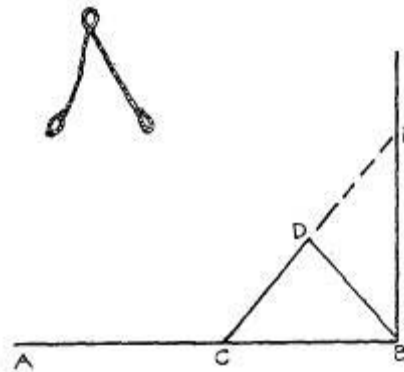

Another method of laying off a right angle is as follows: – Cut three sticks in the proportion of 3, 4, and 5 (e.g. in feet). Lay the 3-ft. stick along the line  $AB$  with one end at  $B$ . Complete the triangle  $ABC$  as shown in the diagram.  $BC$  is therefore at right angles at  $AB$ .

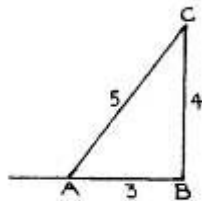

A third method recommended in *First Class Tests* is as follows: – The Scout stands on the known line with his arms fully extended sideways along it. He then sights along it over each of his outstretched arms in turn. He now looks to his front and closes his eyes. The hands are brought forward sharply to the front, at shoulder level, till they meet with a clap. The eyes are opened and a sight line taken on some convenient object to which the hands are now pointing. This sight line will be at right angles to the original line.

*Thumbs up!* – An interesting method of estimating distance is as follows: – Clench the right fist, extend the arm and hold the thumb upright. Close the LEFT eye and hold the thumb so that its *left* edge is on the object. Open the left eye and shut the RIGHT eye. Estimate the distance which the thumb has jumped and multiply this by 6. This gives an approximate figure for the distance – try it out.

**Hints for Judging Distances.** – (As given in *Brown's Boy Scout Diary.*)

Judging distances is a branch of a Scout's work which can be readily acquired but which requires practice.

Never make a wild guess at a distance; have some such method as is given in the following: –

- At 50 yards a person's mouth and eyes can be clearly seen.
- At 100 yards a person's eyes appear like dots.
- At 200 yards all parts of the body, badges, etc., can be seen.
- At 100 yards the face is indistinct.
- At 400 yards the movements of the legs can be made out.
- At 500 yards the head and hat can be seen and colours distinguished.
- At 600 yards the head is like a dot.
- At 700 yards it is difficult to distinguish the head.

**Points to be observed.** – The distance is usually overestimated when: –

- Looking over broken ground.
- In a dull light.
- Object is in the shade.
- Heat haze is rising from the ground.
- Both background and object are the same colour.
- Kneeling or lying down.

The distance is usually under-estimated when: –

- The air is clear and the sun is shining brightly on object.
- Looking across level ground, snow, or water.
- Colour of object is different from the background.
- Looking uphill or down.

**Heights.** – As in the other estimation tests make an estimation first and then check by some method – by actual measurement if possible.

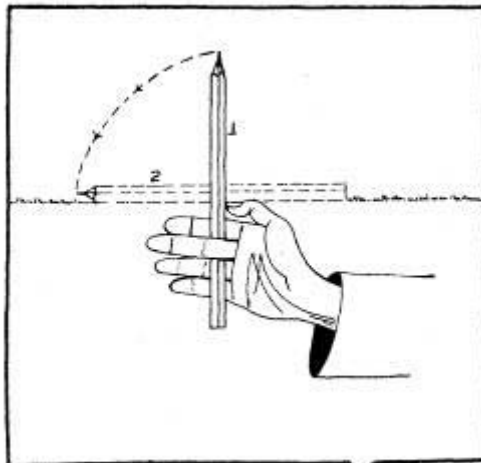

1. *Lumberman's Method.* – To use this method it is necessary to stand sufficiently far away so that the whole height of the object can be seen. Hold a pencil at arm's length from the body and arrange that the tip of the pencil coincides with the top of the object, *e.g.* a tree, and move the thumb down the pencil until the thumb appears to be at the base of the tree. Swivel the pencil through a right angle about the point touched by the thumb, keeping the arm steady. Note the point on the ground where the tip of the pencil now appears to rest. Pace the distance from this point to the foot of the tree – this is the approximate height of the tree, A Scout staff may be used for this although it is much harder to make a steady turn through a right angle owing to the weight of the staff and the difficulty of keeping it exactly upright in the first instance.

2. *The Perspective Method.* – This is a method often used by the artist. Either make a mark on the object whose height is being determined, *e.g.* a tree or a building at a known level (say 6 ft.) or get a friend of known height to stand against the object. Hold a pencil at arm's length from the body and see how often the marked height or the height of the friend appears to go into the height of the object. If this appears to be *four* times then in the case of the friend 6 ft. high the object, would be 24 ft. high.



3. *The Indian Method.* – The diagram is really self-explanatory. Walk away from the object whose height is to be measured with the back to it, until by looking through the legs as shown in the diagram the top of the object can just be seen. It is wise to try this first with some object whose height can be measured – then walk the measured distance away from the object, stand with the feet apart and try to get the correct stance to enable the top of the object to be seen. Use this stance for future estimations or the result may not be too encouraging.

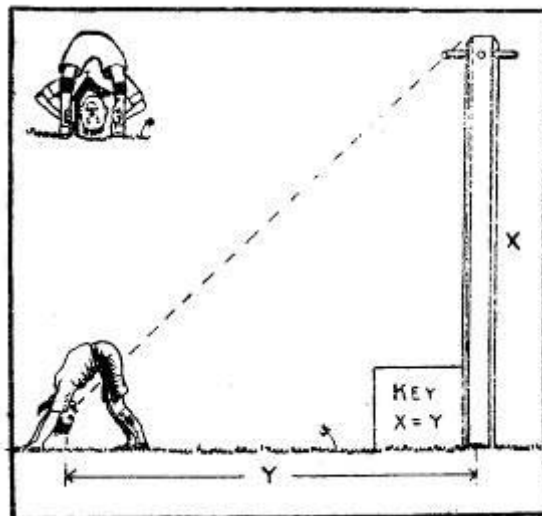

4. *The Shadow Method.* – Measure the length of the shadow cast by a Scout staff A and express as a fraction thus: –

$$\frac{\text{Length of staff}}{\text{Length of shadow}}$$

The height of a Scout staff is known, e.g. 5 ft. and its shadow cast on a sunny day may be 2½ ft. so that the fraction given above becomes  $\frac{5}{2\frac{1}{2}} = \frac{2}{1}$

Without *wasting any time* measure the length of the shadow cast by the object. If the length of the shadow cast by the object is 10 ft. its height will be 20 ft. To find out just why the two measurements – shadow cast by the staff and by the object – must be measured within a minute or two of each other, measure the length of the shadow cast by the object at, say, 6 p.m. and again at 7 p.m. (on a summer's evening).

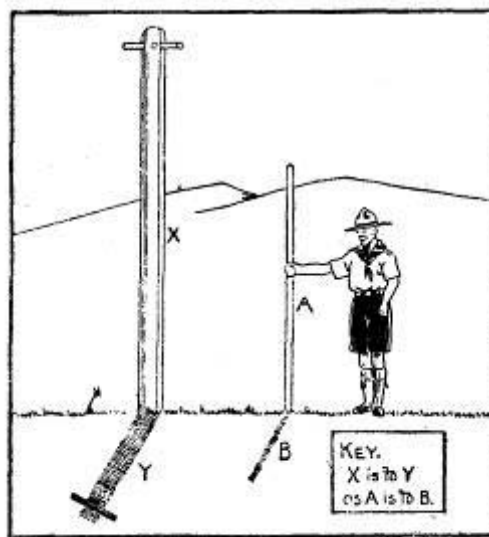

5. *The Right Angle Method.* – Make a cardboard right-angled triangle with the two shorter sides equal in length or use a wooden set square. For accuracy attach a small plumb line as shown in the diagram – this can consist of a bead at the end of some stout thread. Place this triangle at the top of a Scout staff of known height and sight along the long side (hypotenuse) moving backwards until the top of the object can be seen along the long edge. The plumb line is to enable the card and staff to be held vertically all the time so that one of the short edges is parallel to the ground. The distance the observer is from the tree PLUS the height of the staff to the base of the triangle is equal to the height of the object.

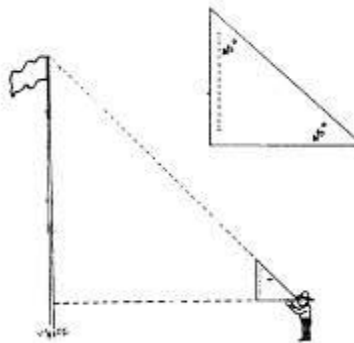

6. *The Chiefs Method.* – (As given in *Scouting for Boys*.)

Pace any convenient distance from the base of the object whose height is to be measured and there set up a Scout staff whose height is already known. Pace on in a straight line until it is possible by crouching down and squinting upwards with the eyes close to the ground to see that the top of the staff comes in line with the top of the object. Mark this spot and then work out the following fraction.

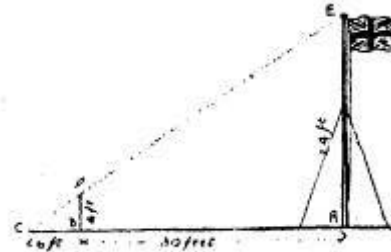

$$\frac{\text{Height of staff} \times \text{Distance from eye to base of object}}{\text{Distance from eye to staff}}$$

– the answer is the height of the object in feet.



7. *The One-in-Twelve Method.* – Walk away from the base of the object whose height is to be determined for 11 “UNITS”, e.g. yards. At this point set up a Scout staff. Pace on for *one* more unit and then get right down close to the ground so that the eyes are as near ground level as possible and look towards the object being measured. A friend moves his hand up and down the staff (as illustrated) until he comes to a point on the staff where the observer’s eye, the friend’s hand and the top of the object appear to coincide. This point should be marked carefully. The distance from the friend’s hand to the ground in INCHES is equal to the height of the object in FEET.

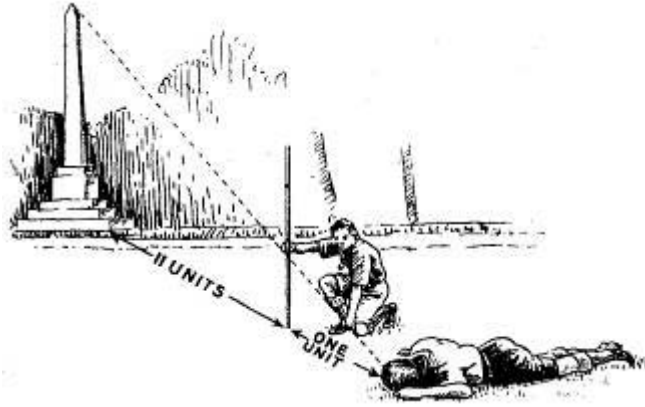

The information given here should enable Scouts (and others) to estimate and check with reasonable accuracy, and work of this sort is very valuable in field sketching and in simple map-making.

**CHAPTER VII.**

**USEFUL INFORMATION ABOUT MAPS.**

A MAP is a fine companion for hiking or rambling providing a wealth of information about the countryside being traversed. To get the most out of a map it is necessary to understand it – what it is, how it was made and the meanings of the numerous markings on it. A map is simply an attempt to represent a picture of the countryside on a piece of paper of convenient size. It is a proportionate picture of a part of the earth’s surface as viewed from above and shown on a flat surface. All distances are reduced equally to enable a large area of country to be depicted on a relatively small map. It is excellent practice to go to the top of a hill or a tall building and to look out over the countryside which will be spread out in front of the observer like a gigantic map. Aerial photographs also help to give an excellent idea of the real appearance of the countryside as viewed from above. In the case of the 1-inch Ordnance Survey map (the type in general use) 1-inch measured on the map represents 1 mile of actual country. As explained in the chapter on “Scales” the scale of a map is sometimes represented by a fraction known as the “Representative Fraction”. The distance on the map and the distance on the actual country is given in the same unit of measurement, e.g. 1-inch on the map represents 63,360 inches (1 mile) on the country and the fraction is written as  $1/63,360$ .

A sketch map or field sketch is an *approximate* picture of a portion of the earth’s surface as viewed from above and shown on a flat surface.

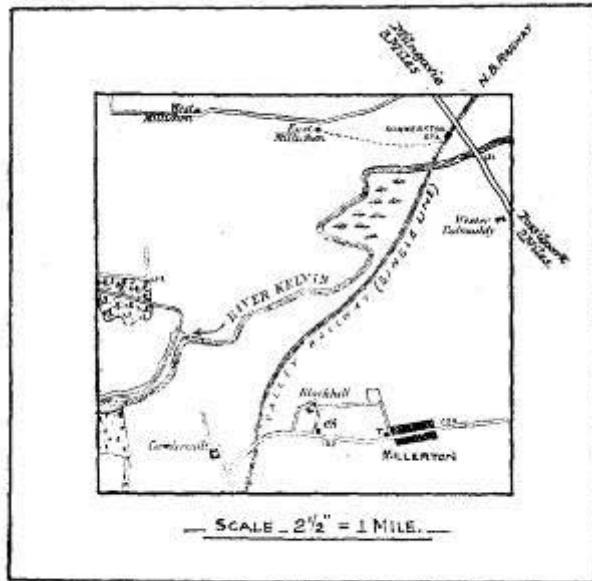

Diagram A.—Map of Section of Country.

A *plan* is an accurate drawing, on a flat surface, of anything viewed from above. A map drawn to a large scale is often called a “Plan”.

Naturally it is impossible to depict hills and valleys, etc., on a flat map. These variations in the level of the ground must be indicated on the map as otherwise much of its usefulness would be lost. The following methods are used by the makers of the maps to show these ground variations: –

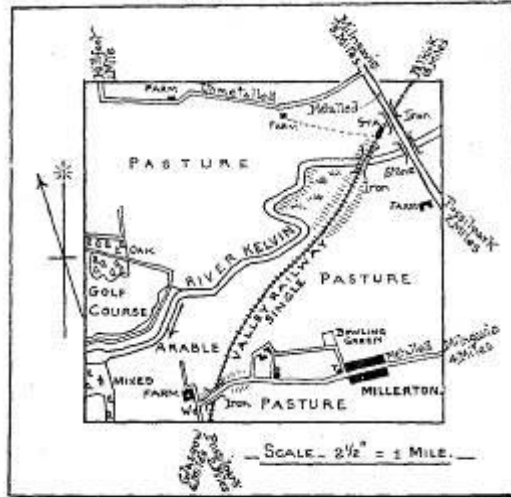

Diagram B.—Sketch Map of same Section of Country.

**1. Contours.** – This is the chief method used for showing hills on the 1-inch map. They are lines drawn through points of equal height above sea level. The path followed by each contour represents the same height all through its course. The sea level contour is termed “0” and higher ground is shown at intervals of 50 ft. or 100 ft., *i.e.* there are 100 ft., 200 ft., 300 ft. contour lines and so on. The illustration should make this clear. The diagrams given are self-explanatory.

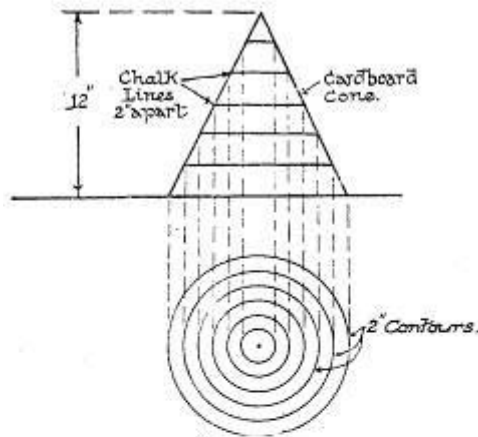

Diagram 1.

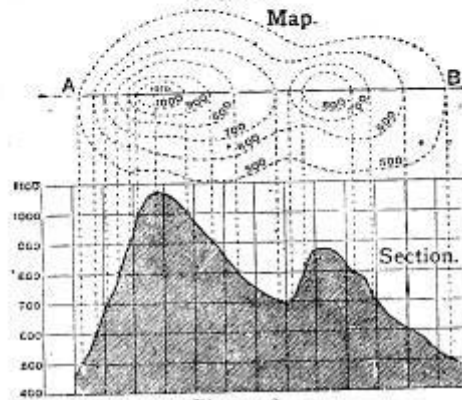

Diagram 2.



The “Vertical Interval” (V.I.) or the interval between two adjacent contours is indicated in the margin of the map. If the slope of the hill is gentle then the contour lines will be wide apart, but if the slope is steep then the contours will be closer together. A study of the way in which the contours run can thus give a good deal of information to the map reader.

**2. Hachuring or Hatching.** – This is a method of indicating the steepness of hills by means of shading. These short disconnected lines of shading are drawn directly down the slopes.



**3. The Layer System.** – This is a “colour” method – the height above sea level is shown by various shades of colouring on the map, a key being provided.

**4. Spot Levels.** – No indication of the shape or steepness of the hill is given by a spot level – it merely indicates the height above sea level at a given point, *e.g.* the brow of a hill. These spot heights are often shown at changes of gradient and so are useful to the map reader.

**5. Bench Marks** (indicated thus  ) are marked on Ordnance Survey maps on permanent landmarks and indicate the height, of each spot so marked, above the average sea level at Liverpool.

**6. Conventional Signs.** – By means of these signs it is possible to indicate on the map a number of important features of the landscape, *e.g.* churches, rivers, railways, woodland and moor. These signs have already been given in a previous chapter, but they may be found at the bottom of every Ordnance map and can always be referred to by Scouts actually using the map. All the different marks or signs on the map have a distinct meaning and much information about a particular piece of countryside may be gained by studying the map at home before traversing the required route. It is interesting to use the map to build up a mental picture of the landscape and then to check that picture by visiting the actual country.

## CHAPTER VIII.

### GRADIENTS AND SLOPES.

**Gradient.** – A gradient is a *slope* expressed as a fraction. Thus a gradient marked 1/10 represents a slope rising one unit in every ten units.

NOTE. – Gradients are calculated on the plan measurement and never on the ground measurement.

#### How to Measure a Gradient. –

1. Take the plan measurement of the slope. It has previously been stated that on a map or plan all distances are measured on a horizontal plane. Therefore if measuring along a line and a slope is encountered, the actual ground measurement is not taken but the horizontal measurement. The method employed is called “stepping”. Suppose the slope to be measured is *AB* as shown in the diagram; a measuring tape and a plumb line are required. Commence at the top of the slope *B*. The tape is always held horizontally when measurements are being made. *Y* moves down the slope, in the direction of *A*, letting out the tape while *X* remains at *B* with the end of the tape on the ground. *Y* moves down the slope, in the direction of *A*, letting out the tape while *X* remains at *B* with the end of the tape on the ground.

When *Y* has gone as far as he can while still retaining the tape in a horizontal position, he notes the length of tape which has been given out and drops the plumb line, noting the spot *C* where it touches the ground when at rest. A stone tied to a piece of string makes an emergency plumb line. Suppose that the length of tape given out is 12 ft. *X* now descends to *C* where he places the 12 ft. *mark of the tape* and *Y* proceeds as before. This is continued until the foot of the slope is reached. The total length of tape given out is the plan measurement of the slope. It is advisable to have a continuous measurement of tape rather than commencing with the beginning of the tape at each step.

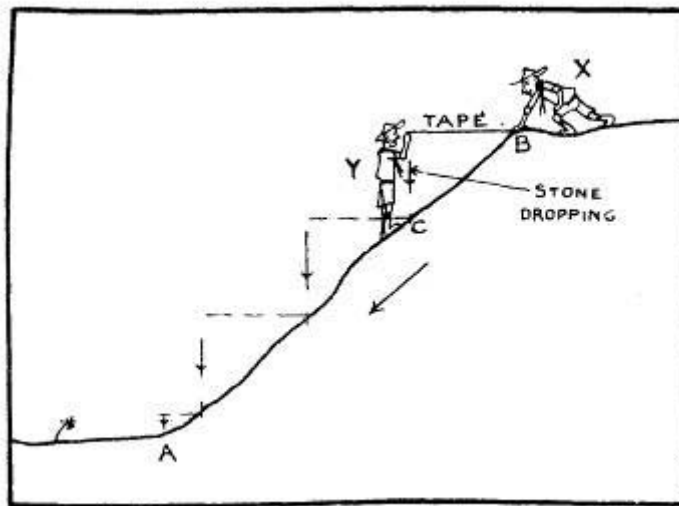

2. Having determined the plan measurement of the slope, along the same line take the actual measurement along the ground. Plot as shown in the diagram – this diagram shows a rise of 50 ft. in 200 ft., which gives  $50/200 = 1/4$  – a gradient of 1 in 4.

V.I. is marked on the diagram – this stands for *Vertical Interval* and represents the difference in height between adjacent contours on a map and is expressed as so many feet. H.E. on the diagram stands for *Horizontal Equivalent* and is the distance in a horizontal line between two adjacent contours and is stated in yards.

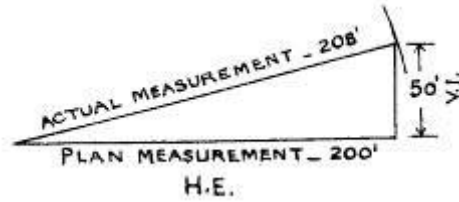

**How to set out a straight line over a hill when part of the line is not visible from the starting point.** – Place a staff at the starting point *A* and one at the finishing point *B*. Send two assistants each with a staff to positions *C* and *D*. The surveyor at *A* must be able to see both *C* and *D*, and assistant at *C* must be able to see *D* and *B*.



*A* sights to *D* through *C*, and signs to *C* until *AC* and *D* are in line. Then *C* sights through *D* to *B*, and signs to *D* until *D* is in line with *B*. This is repeated until *A B C* and *D* are all in alignment, and the correct direction can be followed along these staves for accurately measuring line *AB*.

**To set out a line *AF* where the view is obstructed by a building.** – Place a staff *B* close to the building along the line to be measured, and measure from *A* to *B*. Then set a line *BC* at right angles to *AB*, sufficiently long to clear obstruction. Set another line *CD* at right angles to *BC*. Measure *CD* and add to the length of *AB*. Set a line *DE* at right angles to *CD*, and make *DE* equal to *BC*.

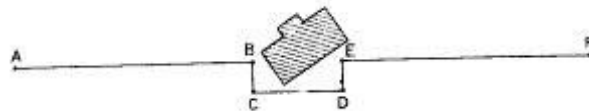

Set a line *EF* at right angles to *DE* and measure *EF*. Then *AB* plus *CD* plus *EF* will be length of line required, and *A B E F* are in alignment.

## CHAPTER IX.

### THE ORDNANCE SURVEY.

THE Director-General of the Ordnance Survey has supplied me with the following information from his office at Southampton. I wish to record my thanks to him for providing me with this first-hand information which all who are interested in maps will find of the greatest interest.

#### Ordnance Survey Maps.

Great Britain may be said to owe its first maps to Scotland. The first survey of the country was made by the Army engaged in suppressing the rebellion of '45 and it is probable that the difficulties experienced by that Army in the uncharted Highlands had much influence in deciding the Government to authorise the systematic survey of the whole country. The scale selected for this survey was one-inch to one-mile, and as it was for the defence of the country it was entrusted to the Board of Ordnance; hence the name "Ordnance" Survey which has been retained ever since.

In those days, however (*i.e.* the end of the eighteenth century) surveying was an art rather than an exact science, and there was no supply of ready trained surveyors in the country whom the Board could engage for the job, but it happened that just when this matter was being considered a proposal had been received from the French for a survey to connect the observatories of London and Paris. This connection was wanted for an investigation of the size and shape of the earth, a problem that was at that time engaging the attention of scientists all over the world. The French proposal having been approved, Captain William Roy, who had been in charge of the survey in the Highlands, was selected to take charge of the work and was given a detachment of soldiers to assist him.

The first stage in any systematic survey is to select and mark a number of reference points suitably distributed over the country and to fix the positions of these with especial care. The points are arranged so that the lines joining them form a network of triangles, and the method of surveying by which their positions are fixed is called triangulation. Triangulation was the method of surveying used also to connect the observatories of London and Paris, and this triangulation, started in 1789, was later extended over the whole country in order to fix the reference points for the one-inch survey, Roy's detachment of soldiers becoming the nucleus of the Ordnance Survey.

The one-inch survey was actually started in 1791, although the first sheet of the county of Kent was not published until 1st January, 1801. The county of Essex followed four years later, and the work was gradually extended northwards, but before it had proceeded very far new demands arose for maps on larger scales, and the military detachment had to be expanded by the enlistment of civilians, firstly for a survey of Ireland on a scale of six-inches to one mile, and later for a survey of Great Britain on the 1/2500 scale (25.344 inches to one mile). When the 1/2500 survey of Great Britain was started (in 1853) the primary triangulation had just been completed, and the one-inch survey had covered most of England. By 1870 the one-inch map of England had been completed, but the more recent portion based upon six-inch and twenty-five inch work was so much better than the earlier sheets that it was decided to scrap much of the original one-inch map and replace it by a new one made by reduction from the twenty-five inch and six-inch work. These early maps were engraved on copper and printed in black only with hills shown by hachures. Copies are still obtainable from the Ordnance Survey.

When England had been completed the survey of Scotland was taken up. The first edition of the one-inch map covered Scotland in 131 sheets, each covering 18 X 24 inches. These sheets

also were engraved upon copper in similar style to the English sheets. Modern maps are no longer engraved, but are drawn on a suitable drawing medium, photographed, printed down on to zinc plates and reproduced on lithographic machines. The maps on scales of one or more miles to one-inch are printed in colours and are generally sold mounted on cloth, and folded.

In recent years many other maps on scales of two, four, ten and more miles to one-inch have been published by the Ordnance Survey. All these, though specially redrawn for each particular scale, are ultimately based on the six-inch and twenty-five-inch surveys. All have to be periodically revised and brought up-to-date. The large scale maps (*e.g.* the sheets on the six-inch and twenty-five-inch scales) are supposed to be revised every twenty years, while the period for small scale maps is supposed to be fifteen years, but the revision of all maps fell into arrears during the war, and in the post-war period changes on the ground have been taking place at such a rate that it has proved impossible to adhere to these periods. By 1935 the problem of keeping Ordnance Survey maps up-to-date had become so acute that a Committee was appointed by the Minister of Agriculture and Fisheries (under whom the Ordnance Survey works) to go thoroughly into the matter and recommend what should be done. This Committee has now completed its work, and its final report has been published.

The headquarters of the Ordnance Survey is at Southampton, but it has a branch office in Edinburgh from which most of the field work of revising the maps of Scotland is controlled. There is, however, one item of revision which is of some interest at the present time and is controlled direct from headquarters at Southampton. This is the overhaul of the National Triangulation. The points of the original Ordnance Survey triangulation were marked by stones or tiles buried deep in the ground and many of them cannot now be found. Reference points are, however, essential for the maintenance of the Ordnance Survey, and it has been found necessary to commence a complete new triangulation, intended eventually to establish points at intervals of four or five miles all over the country. These points will be marked by small concrete pillars about four feet high. These pillars marking points in the primary chain of triangles can already be seen on the tops of hills and mountains all over Great Britain.

Triangulation parties are now working in several areas carrying out observations from these pillars in order to establish points in the secondary system.

To return, however, to the one-inch map. The Ordnance Survey sheets are issued in two styles. The sheets of the regular series are printed in six colours, black for "outline" and names, blue for water features, brown for contours, green for woods and red and yellow for roads, but districts much visited by tourists are also shown on special "Tourist" editions in which hill features are indicated with added clearness by the addition of flat tints of layer colouring or by shading.

All Ordnance maps – large scale as well as small – are printed at the Headquarters offices at Southampton, and are on sale to the public at booksellers' shops all over the country.

### **The Triangulation of Great Britain.**

The existing triangulation of Great Britain was started in 1789 and completed about 1860. The stations were marked by stones or tiles buried deep in the ground. The work was carried out with instruments which, though the best of their time, would now be regarded as primitive and cumbersome. Nevertheless, the accuracy of the primary triangulation was believed to be almost, if not quite, up to the standard of the best modern work, though the checks it had been possible to apply in recent years were not sufficient to establish this beyond doubt. Unfortunately the primary framework had not been completed and adjusted before the 1/2500 survey had begun, and the triangulations for the latter have never therefore been

adjusted into the primary work as thoroughly as would be desirable. It has long been known that there were discrepancies at the boundaries of some of the county projection systems, but it has not been possible to correct these without further observation to connect the county triangulations with the primary framework. Until recently these discrepancies have not caused much embarrassment, and any such work has consequently been postponed from year to year. Recent developments have, however, made it necessary to take steps for the better co-ordination of the various country surveys, and a re-examination of the triangulation position showed that the recovery of a sufficient number of the old buried stations would be impracticable. In 1935, therefore, it was decided to start on a new triangulation framework designed eventually to provide the country with a complete network of triangles of about four mile side, the stations of this system being marked by concrete pillars about four feet, high so designed as to form pedestals for observing instruments and signals.

It had then to be considered whether this new framework could be based on the old primary network and what additions to the latter would be necessary to enable this to be done. It was found that some of the primary stations had disappeared altogether, and that the recovery of a number of others would be somewhat costly and might delay the start of the work. Moreover, many of the old rays are so long that an attempt to re-observe them in the smoke-impregnated atmosphere of the industrialised areas might involve many weeks, or even months, of waiting. It was accordingly decided to lay down a completely new foundation of primary triangulation over the whole country.

The work was started in 1935 and observations commenced in the summer of the following year. By the end of 1938 the whole of the observations for the primary triangulation of Great Britain had been completed except for that part of Scotland lying to the north-west of the Caledonian Canal, which will be completed at a later date.

The measurement of a new primary base line about seven miles long was completed during November, 1937, along the Berkshire Ridgeway in connection with the new primary triangulation. A second such base line was measured in the North of Scotland during 1938.

Meanwhile, the reconnaissance and station preparation for secondary triangulation has been carried on concurrently with the primary work, giving priority to the mining areas in South Wales and Central England.

This work has been observed with Geodetic Tavistock Theodolites manufactured by Messrs. Cooke, Troughton & Simms. The primary triangulation of the whole country will eventually be rigorously adjusted in six large figures. Four of these figures have already been adjusted with the aid of Mercedes M.A. Calculating Machines, and work is proceeding on the fifth.