

Downloaded from:  
"The Dump" at Scoutscan.com  
<http://www.thedump.scoutscan.com>



Editor's Note:

The reader is reminded that these texts have been written a long time ago. Consequently, they may use some terms or express sentiments which were current at the time, regardless of what we may think of them at the beginning of the 21<sup>st</sup> century. For reasons of historical accuracy they have been preserved in their original form.

If you find them offensive, we ask you to please delete this file from your system.

This and other traditional Scouting texts may be downloaded from The Dump.

# THE CREW SCOUTER'S HANDBOOK



SECOND EDITION  
1963

*Originally Published by*

THE BOY SCOUTS OF CANADA, OTTAWA, ONT.

### AKNOWLEDGEMENTS

The Canadian General Council of the Boy Scouts Association extends grateful thanks to the following persons and organizations who have assisted in the preparation of this handbook by giving permission, expressed or implied, to reproduce and adapt material prepared or published by them; or who have given advice or constructive criticism of the material: —

Ernest F. Mills, former Executive Commissioner (Training) of Canadian Headquarters.

The late G. Gerald Purkis, former member of the Executive Staff at Canadian Headquarters and the Greater Toronto Regional Headquarters.

Professor Harold Breen, Ph.D., while at Carlton University, Ottawa, Ontario.

Harold Taylor, former Assistant Provincial Commissioner (Rovers) for Ontario, Delhi, Ontario.

Members of the Ontario Rover Round Table.

Members of the Quebec Rover Round Table.

The Boy Scouts of America, New Brunswick, N.J., U.S.A.

Imperial Headquarters of The Boy Scouts Association, London, England.

Robert R. Robinson, formerly Director of Education of the Alcoholism Research Foundation, Toronto, Ontario.

M.N. Balsillie and J.A. Westwood, Hertfordshire Scout Council, England.

The late W.L. Currie, former Deputy Chief Executive Commissioner, Ottawa, Ontario.

The Royal Bank of Canada, Montreal, Quebec — Monthly Letter.

To the many Rover Scouts and Scouters who have prepared papers for Council magazines and bulletins, and for Rover Moots. The written material they provided has proved to be of real value for research in the writing of this book.

The Canadian General Council of  
The Boy Scouts Association  
Ottawa, Ontario.  
1961.

## FOREWORD

Once upon a time I was a Rover Scout.

I will always remember the helpful guidance I received from my Skipper, and the fine comradeship I enjoyed with my fellow Rovers. I don't believe I ever thanked Skipper for all he did for me during the six years I was a member of the Crew. They were very happy days, full of activity with good companions helping each other out when the going got rough.

In retrospect, it seems strange that we got on so well. On the surface Skipper and I appeared to have so little in common. Without being disagreeable, we disagreed about many things. Our religious beliefs were different. Our political inclinations were not the same. Our attitudes towards smoking, drinking, leisure and nearly every aspect of everyday living were often in conflict.

My companions in the Crew were a strange mixture. Amongst ourselves our ideals seemed as far apart as the poles, and our ideas of what the world had in store for us never agreed.

Somehow, this diversified group accomplished much in terms of Good Turns and brotherhood and open air life. I remember the men who were once young men in that Crew, and the success they have now attained in their lives. What a marvellous influence our Skipper exerted upon us!

Never once did he tell us we were on the wrong trail, but by his quiet example and sincere personal beliefs he encouraged us to solve our own problems and 'paddle our own canoes'. On Good Turns and on rambles his philosophy of living was gradually imparted to each one of us, and our youthful radicalism was tempered and altered without attempting to destroy our individuality. I think it is fair to state that from our Crew emerged a group of happy, healthy, useful citizens.

To such men as Skipper, we owe a dept of gratitude for the production of this handbook. Former Rover Scouts and Rover Scout Leaders, as well as men and young men presently engaged in Rover Scouting have contributed to its production. I sincerely hope that Rover Scouts yet to come will benefit from what this book has to offer, and the Rover Scout Leaders will find it helpful in the leadership of their Rover Crews.

G.G. PURKIS

**CONTENTS**

<b>Foreword</b>	5
<b>Chapter 1 What is Rovering?</b>	7
Quest No. 1 Purpose	7
Quest No. 2 Rovering	7
<b>Chapter 2 The Young Man and You</b>	8
Quest No. 3 Young Men	8
Quest No. 4 Their Leader	11
<b>Chapter 3 The Rover Crew</b>	13
Quest No. 5 Starting	13
Quest No. 6 The Rover Scout Leader	19
Quest No. 7 Teams and the Rover Scout Mate	22
Quest No. 8 The Crew Executive and the Crew-in-Council	23
Quest No. 9 The Rover Scout Den	25
<b>Chapter 4 The Rover Programme</b>	27
Quest No. 10 The Rover Scout Sponsor	27
Quest No. 11 The Rover Squire (The Probationary Stage)	30
Quest No. 12 The Rover Scout (The Training Stage)	36
Quest No. 13 The Service Rover (The Service Stage)	40
<b>Chapter 5 Ceremonies</b>	41
Quest No. 14 Progressive Rovering	41
Advancement (Troop to Crew)	42
Acceptance (Becoming a Squire)	43
Investiture (Becoming a Rover)	43
Leave-Taking (Becoming a Citizen)	46
Openings and Closings	46
<b>Chapter 6 Crew Meetings</b>	47
Quest No. 15 In the Den	47
Quest No. 16 Out-of-doors	51
Quest No. 17 Co-educational and Social Activities	53
<b>Chapter 7 Rover Craft</b>	56
Quest No. 18 Crew Quests	56
Quest No. 19 Individual Quests	59
Quest No. 20 Ramblings and Logs	61
Quest No. 21 Camping and Camp Gear	65
Quest No. 22 Fitness	90
Quest No. 23 Living with Others	96
Quest No. 24 The Use of Leisure	98
<b>Chapter 8 Important Principles</b>	101
Quest No. 25 Duty to God	101
Quest No. 26 Duty to Queen	102
Quest No. 27 Duty to Neighbour	105
Quest No. 28 The Scout Law and Promise	106
<b>Chapter 9 Success</b>	108
<b>APPENDIX — HISTORY</b>	110

CHAPTER ONE

## ***What is Rovering?***

---

### *Quest No. 1 — Purpose*

**The Aim** | Rover Scouting has as its aim good citizenship through the development of individual character. This is accomplished by: —

1. Training young men in habits of observation, obedience, and self-reliance in the school of woodcraft.
2. Impressing loyalty and thoughtfulness for others by instruction and by giving service to others.
3. Teaching young men services useful to the public and handicrafts useful to themselves.
4. Developing mental and physical powers of the individual through wholesome social contacts and activities.
5. Leading the individual to develop spiritual and social values by example and association.



The aim is common to all three Sections of the Boy Scout Movement. While the aim may be the same it is important to keep in mind that the methods employed to attain this aim are progressive. The Wolf Cub Pack trains the child to become a boy with desirable character traits. The Boy Scout Troop develops these character traits in a boy as he advances to young manhood. The Rover Scout Crew has as its aim the further development of good character in the young man to enable him to become a mature adult, a good citizen; one whom we would be pleased to call a friend and neighbour.

The home, the church, and the school are the three basic pillars of our society. What is done in Rover Scouting complements the influence of these agencies.

### *Quest No. 2 — Rovering*

**What is Rover Scouting?** | In very clear terms, Baden-Powell has given an “Explanation of Scouting” in the first few pages of his book **Scouting for Boys**. This explanation should be read in conjunction with the following.

Rover Scouting is a “continuation” of the training that is given to Wolf Cubs and Boy Scouts with good citizenship as the final goal.

Rover Scouting covers the period during which a young man is “finding himself” — that is, he is developing his character by putting into practice in a wider world the principles of the Scout Law and Promise. It is of the utmost importance to remember that the main and immediate aim of Rover Scouting is to provide a further period of “Training” for young men.

If we are looking for a specific programme of badges, tests, and activities to tell us how to do Roving we will seek in vain. Unlike Cubbing and Scouting, Roving is not a programme. **There is no programme for the Rover Crew, but there is a programme for each Rover Scout.** Every member of the Crew may have different interests and Rover Scouting endeavours to develop these. It follows that each Rover will have to set his own programme to suit his own needs. However, we can help each to seek and aspire to make the best use of his talents. Thus, the individual embarks upon a series of Quests designed to help him “find himself”.

Why, then, are there Rover Crews if the individuals in the Crew cannot follow a common programme? Rover Scouting was described by Baden-Powell as a “brotherhood of the open air and service”. Brotherhood, open air activity, and service are the common meeting grounds.

Rover Scouting also provides a short period at the end of training for each one to test his ideas of brotherhood and service in the community before finally taking leave of the Crew.

To sum up, Rover Scouting is an individual training experience for young men, carried out in a democratic setting, with Scouting ideals governing the conduct of individuals and the group as a whole so that they may individually and collectively give practical expression to these ideals in their adult lives.



## CHAPTER TWO

### ***The Young Man and You***

---

#### *Quest No. 3 — Young Men*

Before we get involved with the mechanics of Rover Scouting let us take a close look at the nature of the raw material with which we work — the young man. The secret of success lies in attempting to understand the attributes of young men and in using these attributes as the basis for training.

**The Period** | Young men of Rover age are still in a period of adolescence. For our purposes adolescence may be described as that time of life which lies between boyhood and manhood, of the period from about the twelfth birthday to the twenty-first.





When we speak of adolescence we must be sure of the meaning of this term. It is generally considered to begin at puberty and end at maturity. Puberty is easy to define but maturity has many connotations. Legal maturity is generally considered to be twenty-one. Sexual maturity is quite early — it may be anywhere from fourteen to seventeen, or even eighteen. Even more vague is social maturity. It may be attained anywhere from the late teens until fairly late in life. Maladjusted people sometimes never attain social maturity.

The Boy Scouts Association has not accepted twenty-one as the end of its citizenship training programme in an arbitrary manner. A young man is a citizen at twenty-one and we must achieve our goal in time for him to take his legal and rightful place as a worthwhile citizen.

Adolescence may be divided conveniently into three sections. Early adolescence is from eleven to fifteen or sixteen; middle adolescence is from fifteen or sixteen to eighteen or nineteen and late adolescence covers the balance of the period until maturity. In Rover Scouting we will be concerned with boys and young men in middle to late adolescence.

The importance of having boys and young men engage in healthy physical and social activities under sound leadership and good company cannot be over-emphasized.

**Characteristics of Youth** | It is not easy to understand young men. By the time boys are of Rover age many influences have been at work developing individuality, and it is virtually impossible to give a list of characteristics applicable to all. However, there are some guiding principles that the leader of youth will find helpful if they are used judiciously as considerations and not as unalterable conclusions to be applied.

1. In dealing with young men it is necessary to guard against the error of attributing to them, in a wholesale or arbitrary way, the characteristics which their years suggest. The maturing process of whole groups may vary greatly between one group and another, and within that group, depending upon environment, educational, economic, and social background.

2. The time of maturity differs with each individual. He must be treated as an individual, and his needs studied and met.

3. Adolescence is the period during which the young man is faced with practical questions of membership in social groups, conformity to social standards, vocation, friendships, public opinion, individual beliefs, leadership, mass hero worship, personal appearance, sex, and ambition. These questions and many more now press for answers. In Rover Scouting this process is called “finding himself”.

Young men very often resent outside interference in the solving of their problems. This is quite natural, because this is a part of the maturing process which gives them the opportunity to face up to the responsibility of self-control and self-direction. Sooner or later all adults must take a lively interest in the management of their own conduct. The privilege to originate plans independently of others, and the liberty to accept or reject the judgement of elders is looked upon as the young man's inherent right. Youth is independent and creative. Young men will argue for argument's sake, and while they may appear completely hostile to adult suggestion, they are weighing both sides of an argument. They appreciate advice, but they tend to reject dogmatic views. Young men must be given tactful guidance and encouraged to solve their own problems.

4. Physical changes in middle adolescence are not as conspicuous as in the earlier years, but a "settling down" process is now evident and during this period physical habits are formed. This is the period of life when youth is trying out his physical prowess. This is when the young man is "finding himself" physically. From this period to late adolescence young men are gradually attempting to control the body by conscious effort. They seek to master physical skills as exemplified by vigorous sports and social activities such as dancing. Therefore, it is essential to provide young men with opportunities for engaging in activities of this nature.

5. Social development undergoes radical changes during the period of adolescence. Beginning with strong influences of the gang, it progresses, during the period corresponding with Rover Scout membership, to the greater influence of a few friends who may change frequently and with a particular activity being pursued. Group life will still be important, but not in the intense way of the gang. It is obviously necessary to maintain a flexible organization which will be capable of meeting these changing needs in the group.

6. Loyalties, too, vary radically throughout the three periods of adolescence. The home and the school are usually the centres around which activities are pursued in the early stage. If the boy's family is a church-going family, the church may be another centre around which activities are built.

In middle adolescence the loyalties to these centres are subjected to severe upheavals. Young men now find much to interest them away from home, and it becomes a real problem for parents to maintain parental discipline. In fact, parental discipline disappears as such and ultimately becomes replaced with self-discipline based upon respect for others and love for home and family. This must be a prelude to marriage and is part of the maturing process.

The influence of the school diminishes. It has been estimated that only twenty-five per cent of young men who proceed to schools of higher learning do so of their own volition. The balance are lead or directed to universities by their elders. The desire for education is replaced by a desire to be self-dependent by becoming a wage-earner. This, too, is part of the maturing process, but one which should not be hurried.

During mid-adolescence dogmatic religious teachings are often questioned. From mid to late adolescence youth may be influenced by sound leadership practices to re-establish church connections which become based upon intelligent devotion. Leaders of youth must work in close harmony with the home, the church, and the school.

7. Youth is "in a hurry", and inclined to be impetuous. This desire is accomplished by a lack of skill and knowledge to do the very things they crave. On the surface, they appear to be quite contemptuous of and impatient with the slower reasoning processes of adults. Radical ideas and actions are both a part of the desire for action. Rules of conduct, usually set by their elders, are challenged. Youth wants to have a say in how things should be done.

They have their own ideas of what is “right” and what is “wrong” — but, all too often, what is “right” today may take on a different hue and be “wrong” tomorrow. There appears to be no stability of concepts. There is nothing “wrong” with this situation. It is another phase of growing up which will pass with maturity, although here, too, adults waver and probably rightly so. It is the rashness which disappears with maturity. In dealing with young men it is imperative that they be led to understand and accept a reasonable code of discipline. Sooner or later we must all learn that we are subject to discipline by a higher authority.

8. During mid-adolescence boys start taking an interest in girls, culminating in courtship in late adolescence, and marriage soon after this period has passed. In many cases marriage actually takes place during late, and even middle adolescence. We cannot train young men unless we include girls in our programmes.

**Psychological Needs** | All humans are subject to certain psychological needs. Some of these needs are for affection, belonging, and recognition; others pertain to the desire for achievement and independence. Finally, the most important and basic need is that of self-respect.

Young men must have friends, male and female. They must be led to realize that they are growing mentally, physically and socially. They must be made to feel at home amongst their contemporaries and elders. They must have the opportunity to receive acclaim for their accomplishments while in the company of their companions. They must be made to feel that they are masters of their own fate and that their views will be heard and considered. They must be made to feel that they have an important part to play in the scheme of things and that they are important as individuals.

**What Rover Scouting Has to Offer** | Rover Scouting is geared to meet many of the physiological and psychological needs of older boys and young men. The organization and activities are therefore flexible to permit and encourage individual and group development.

### *Quest No. 4 — Their Leader*

Now that we understand something of the nature of young men of Rover Scout age, let us examine the type of man who will be acceptable as their leader.

**The Choice of a Leader** | Remembering that young men have a strong desire for self-determination, it is quite obvious that a leader of their own choice stands a far better chance of success than a leader imposed upon them. A group of young men interested in Rovering will naturally gravitate towards an older person who can meet their needs. The period of blind hero worship has passed with boyhood, and as young men they are more discerning and choose their leader with the practical thoughts of the needs of their Rover Crew in mind.

**Characteristics and Qualifications** | Personal appearance will play a major part in the initial choice. Young men like a man who is up-to-date in his choice of clothing. The man need not adopt the radical dress which may be prevalent in the current styles, but he should be well groomed.

Young men will also be attracted to men with young ideas. The leader should enjoy things which young people like doing. In other words, he must be young at heart.

The leader of young men must keep an open mind on the problems of youth. He must be a better listener than a talker. In the presence of youth there is no room for dogmatic views, but rather all avenues must be explored so that youth may find its own answer.

The leader of young men must be willing to stand aside and let them make their own mistakes. However, this does not mean that leadership must be passive. Real leadership is necessary to bring out the pros and cons of the problem of the moment so that reasoned judgement may be developed. For example, if the group decides to hold a social planned to last from 9:00 p.m. until 1:00 a.m., and it is obvious from parent reaction that this is considered far too late on a school night for both the fellows and their girls, it is useless to tell them that the social must close at 11:00 p.m. If we do, *this* social will cease at 11:00 p.m., but the same problem will recur at the next gathering. However, if we approach the problem as something to be solved by all concerned we develop reasoned judgement. The problem is stated — “One in the morning is considered far too late to close the social. What can we do about it?” The pros and cons are drawn out — “Will the parents of any one of your dates or your girl friend’s parents stop you from attending another social if we close at one?”



It is not so much the successful completion of a project or problem which is important, but rather the method of approach and the lessons consciously or unconsciously learned that count. When a project is completed, successfully or unsuccessfully, the skilled leader will help the participants draw conclusions. The “I told you so” attitude is doomed to failure, but if the leader becomes one of the group and helps with the discussion by posing the question, “If *we* had followed this line of action, what would have happened?”, the young men will be led to develop powers of evaluation of their actions.

Young men want their leader to maintain an open door policy. He must always be approachable. They want a friend and counsellor in whom they can confide. The leader should not pry into the individual’s personal problems, but if the leader has proven himself to be a man of his word and loyal in every respect, confidences will be advanced without prompting.

This leads to an understanding of those abstract qualities of honour and loyalty. Young men can detect sham very quickly and they are inclined to classify many things as flaws in character. For example, the man who utters disloyal remarks about his employer, or makes disparaging allusions to others in authority, or indulges in petty dishonesty, will soon lose the confidence of those whom he is trying to lead.

Young men appreciate stability. A man who has found happiness in his way of life and in his occupation, without being smug about it, or avoiding opportunities of improving himself or of helping those about him, has the necessary qualifications to develop into a leader of youth.

The leader of young men must be capable of understanding the needs of young men and lead them through an understanding of this phase of life. His job is to help them see and adjust to the world as it is, without erecting barriers to reality and without stifling idealism and ambition. Young men will learn and profit by experience, and it is a mistake to attempt to protect them from all errors in judgement. For that matter, young men will reject over-protection and will attempt to do the very things the leader thinks unwise, but the attempts will be made under unsupervised conditions, and this may be positively harmful.

While the leader must be reconciled to taking a back seat and see his pet schemes rejected or overhauled by those he leads, he must stand firm on principles and standards. Within these bounds control of a group of young men must be left to the young men themselves.

To sum up: a good leader should be up-to-date and youthful in his ideas. He must be permissive in his dealings with young men, but must also have a fully developed sense of values and standards of his own, which are mature and yet flexible enough to permit him to accept the rebelliousness of youth without himself becoming angry or resentful.

In other words, the good leader must possess a judicious combination of tolerance and understanding together with personal maturity and control. He must blend with the young men he leads, while a part of him stands always outside the group and alone, as a source of reliable authority and stability.

**Summary** | What has been said about the leader of youth may sound idealistic. It is! This does not mean that anyone who does not possess all of these characteristics will fail. However, the leader who recognises his shortcomings (and we all have them) will be in a far better position to give real leadership than the person who plunges on blindly in self righteousness. It is necessary to understand oneself before attempting to understand others.

## CHAPTER THREE

### ***The Rover Crew***

---

#### *Quest No. 5 — Starting*

**Presenting the Facts** | It pays to advertise. Scouting itself was born as a result of the mass distribution of information in the form of fortnightly editions of **Scouting for Boys**. This was followed by speaking trips by the Founder which eventually took him all over the world to spread the news about Scouting. Every effort was made to enlist the support of influential people as well as the parents of the boys themselves.

Under this heading of “Presenting the Facts” much will be said which does not directly concern a Rover Scout Leader. However, the Rover Scout Leader should understand from where he may expect support, and from this understanding he can infer how he should fit into the scheme.



Today we live in a world of high pressure salesmanship. From all sides we are assailed with “buy this, by that, buy the other thing”. In our everyday lives we are influenced through the medium of advertising in what to buy and what to do.

People expect this treatment, and Scouting cannot ignore the approach. Through advertising we “create a demand” for our product.

How do we create a demand for Rover Scouting? Constant repetition is one method. From the day a boy joins the World-wide Brotherhood of Scouts he should start to hear about Rover Scouts. His Cubmaster, and later his Scoutmaster, must constantly emphasize that it is a natural step to proceed from the Pack through the Troop to the Crew.

Rover literature must be in every Troop library. It is a very good idea to present a copy of **Rovering to Success** to a Scout when he attains First Class grade, or as a fifteenth birthday present.

To create a demand for our product, its desirable features must be made known. We must say to young men, “If you enjoy the company of older fellows and girls at parties, picnics and social affairs; if you wonder what the future holds for you and your life’s work and you desire to explore the possibilities around; if you want to share in the responsibilities of citizenship; if you like clean, healthy, outdoor life with adventurous activities; if you like helping other people — then Rover Scouting will interest you”. This approach can be used on the Scout and the non-Scout alike.

Another principle of advertising that must be applied to creating a demand for Rover Scouting is to make sure that the standard, once stated, is maintained. In other words, if we make the desirable features of Rover Scouting known, these features must be a reality and not merely a theory.

In the strict sense of the word we are not in competition with other youth movements, but nevertheless we must recognize the fact that young men’s time is being sought after even within our own Movement. We must have a burning zeal for Rover Scouting and believe it is one of the best things for young men to join in order to develop themselves to the fullest extent.

For example, there are many sixteen-year-old fellows actively engaged as Patrol Leaders and Troop Leaders in Boy Scout Troops. This is a perfectly desirable situation provided Boy Scouting is still benefiting the young man concerned. However, in some cases, Scoutmasters hold their older boys because they have reached the stage where they are of real value to the Troop. While this may also appear desirable as far as the Scoutmaster and the Troop is concerned, it may be harmful to the boy concerned. Most young men of sixteen are still not mature enough to give ideas as readily as they receive them. Scouting, in the form of Rover Scouting, still has much to contribute to the young man’s development along the road to good citizenship.

It is suggested that, when a Boy Scout becomes really useful to the Scoutmaster, aside from his ability to run a Patrol if he is a Patrol Leader, it is time to pass the boy along to the Rover Crew for further training. After all, when a boy has successfully completed his training in high school, he is not retained as a teacher's helper because he knows the subjects. Rather, he goes on to a school of higher learning.

If the older boy is retained in the Troop, he may gradually miss one or two meetings, then a few more, and ultimately disappear from the membership of the Troop. This is a natural development and should be expected. However, how much better it is to pass these young fellows along to the Rover Crew for a few more years training while they are still interested in Scouting.

This leads us to another point in creating demand for Rover Scouting. The Group Committee must be made to realize that young men should advance to the Rover Crew if the total Scout programme is to be effective. They should be made to realize that they are doing only part of their job if Rover Scouting is not in their Group.

There is one other point which must be dealt with under the heading of creating demand for the organization of a Rover Scout Crew. In far too many cases older Scouts are suddenly catapulted into adult responsibilities of being an assistant leader in the Pack or the Troop. Section leadership is for mature adults, and while we must concede that many eighteen-year-olds make excellent assistants in terms of knowledge of Scouting skills, it is rare to find a young man of this age group mature enough to have developed a philosophy which makes an indelible imprint upon the characters of the boys being led.

Young men who are active in Scout Troops should have a break of several years before going back to a Section as a leader. They will be better leaders because of it, and furthermore, they will be more acceptable to the boys concerned. If we do our job right in Rover Scouting we feel certain that some of our leadership problems will be licked. However, let us not get the idea that Rover Scouts are necessarily in training to be Scout Leaders. Far from it. They are being trained to be good citizens. Again, if we do our job properly we should expect to get our fair share of these potential leaders back into our Movement as leaders of boys, Group Committeemen, and Council members.

**Sources of Members** | As Rover Scouting is the natural outcome of Boy Scout training in the Boy Scout Troop, there comes a time in every Boy Scout's career when the Boy Scout Troop has completed its job of training him. This usually occurs about the sixteenth birthday. Young men in this category may seek admission to a Rover Scout Crew.

If a young man is a Boy Scout he must be recommended for advancement by his Scoutmaster.

Young men who have never been Boy Scouts, or who have dropped out of the Boy Scout Troop also may apply for membership in a Rover Scout Crew.

If a young man is not advancing directly from a Troop to a Crew he will be admitted, providing he is willing to live up to the Spirit of the Scout Law and Promise and learn to do practical Scouting.

Anyone seeking admission to the Crew must have the approval of the Rover Scout Leader and the Crew.

**The Responsibility of the Sponsoring Institution and its Group Committee** | Once the Scouters of the Pack and the Troop have created a demand for the formation of a Rover Scout Crew in conjunction with their Scout Group, the young men themselves will probably insist upon the formation of a Rover Scout Crew. From this point on, the Sponsoring Institution and the Group Committee have definite responsibilities which must be met if the plan of starting a Crew is to bear fruit.

First of all, the head of the Sponsoring Institution, in consultation with the people of his institution, who are charged with the responsibility of attending to the needs of the youth of the institution, must give approval to the plan. When approval is forthcoming the head of the Sponsoring Institution will instruct the Group Committee to proceed with the necessary steps for form a Rover Crew. The Group Committee now carries the ball for the Sponsoring Institution.

The Group Committee has the real responsibility for organizing a Rover Scout Crew for the young men who are desirous of joining. They must apply to the next senior Council for permission to organize a Crew. On its part the Council will supply expert advice and direction.

As the Crew is an integral part of the Boy Scout Group, and the closest liaison must be maintained between the Rover Scout Leader and the Scouters of other Sections in the Group, it is essential to put the matter of starting a Crew to all of the Scouters concerned, and discuss any difficulties which may be encountered.

The Group Committee is responsible for securing adequate meeting facilities, and a suitable Rover Scout Leader. This should be done in consultation with the would-be Rovers. Subsequent chapters in this handbook deal with these subjects. In addition, the Group Committee must arrange for the registration of the Rover Scout Crew once it is under way, and attend to the annual re-registration of the Crew.

**Numbers** | As long as four young men wish to be Rover Scouts the formation of a Rover Crew should be given serious consideration. In a very short time additional young men will wish to join if real Rovering is being carried out.

Because of the very nature of Rover Scouting, Rover Crews do not grow to be very large. There is an odd exception, but it is rare. From eight to twelve members appears to be a good working unit, but if circumstances permit and all concerned are agreeable, there is no harm in expanding further.

There appears to be a time in the life of most Rover Crews when they no longer attract new members. This may happen for a variety of reasons. It may be because of age difference between the youngest member in the Crew and available recruits; a conscious or unconscious rejection of newcomers; accommodation that limits numbers; activities that are geared to an older age group, and even the personality of the Rover Scout Leader. We must remember that he has been acceptable to the members of the Crew, but this does not imply that he would be acceptable to the newcomer. There may be innumerable other reasons for a Crew ceasing to grow. Suffice it to say that some reasons are because of Crew attitude and some because of attitudes of the potential recruits.

However, if a Rover Crew is in existence and additional young men want to be Rovers, but not in that particular Crew, there is good reason for organizing a second Crew in conjunction with the Group. Crew Number One may cease to exist in a few years, perhaps because all members are over age. This may be the best thing that could happen, as long as there is a Rover Crew forming or functioning to take care of the young men who wish to advance from the Troop, and who may wish to join from outside the Troop.

This may be a never-ending cycle, but let us remember that we are not interested in the perpetuation of a particular Rover Crew as a Section of a Group. We are interested in the training of young men by whatever organization pattern appears to be sound.



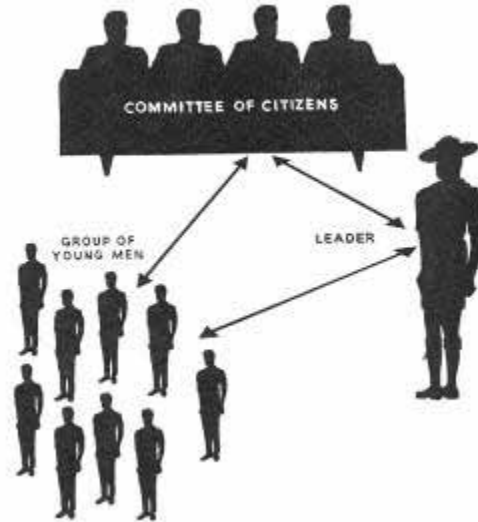

**First Meetings** | First meetings will set the standard and tone of subsequent meetings, and therefore they are important meetings.

### *1. The Rover Scout Leader*

Normally a Rover Crew will start to function before a Rover Scout Leader is appointed and, therefore, it will be necessary to have some other adult guidance in this interim period. Perhaps the Scoutmaster, or an Assistant Scoutmaster, or even one of the Group Committeemen may volunteer to supervise a few meetings. In any event, the Rover Crew should not continue to function very long without a Rover Scout Leader. The choice of a leader should be one of the earliest decisions made during the first meetings.

It will be necessary to have the Commissioner or his duly appointed representative invest the new Rover Scout Leader if he has not yet been invested.

One of the Rover Scout Leader's first jobs should be the setting up of a personal record for each member of the Crew. Factual information can be secured from the Scoutmaster of the former Scout. It will be necessary for the Rover Scout Leader to get to know something of the background, aspirations, and talents of each of the members of the Crew. All of this should be recorded in his record book.

### *2. The Sponsor*

Farther on in this book reference is made to Sponsors of Rover Squires. What do we do when we have no Rover Scout to act as a Sponsor? We will have to make a plan to suit local conditions. For example, if another Crew exists somewhere in the District, members from that Crew can be asked to act as Sponsors for members in the new Crew. It may be necessary to go fifty or one hundred miles or even farther to another town or city to find Sponsors. If this scheme is impractical, the young men may have to be Sponsors for each other under the close supervision of the Rover Scout Leader.

### *3. The Initial Meeting*

The young men will want to know all about Rover Scouting. What uniform is worn? How do we become invested? What are we going to do? These questions, and more, must be answered, not

necessarily in detail, by the leader in charge at the first meeting.

The Crew will have to decide how often and where they will meet. Some Crews meet every week on a stated day, others meet every other week on a stated day, while others meet several times a week. Some are fortunate enough to have a Den of their own. Others find Skipper's basement or living room quite adequate for a start. Some Crews rotate from home to home.

Membership fees will have to be determined, and the rate of weekly dues decided upon. Some sort of bookkeeping system and a bank account will have to be set up immediately. Also, it is a good idea to start a Crew Log at the very first meeting so that the Crew will have a complete history and record of all it has done.

It will be necessary to set up some sort of *pro tem* organization within the structure of the Crew to get things under way. Of course, ultimately the Crew will become properly constituted with Mates, Secretary, Treasurer and other Officers.

#### 4. *And We're Off!*

After the first meeting, which is a "getting acquainted" meeting, as well as an initial organizational meeting, the Crew should start to function with its own members giving strong leadership. If this process is delayed there will be a tendency to lean heavily upon the Rover Scout Leader, and the habit will become increasingly more difficult to break as time goes on.

All meetings should have an opening and a closing. They should begin on time and end on time. This is particularly important in first meetings.

Fun and fellowship should be present right from the beginning. Games, particularly observation games, should be enjoyed by all, and a half hour of fellowship after the close of the meeting with a cup of coffee and a biscuit usually is welcomed.

#### 5. *But What Do We Do?*

First meetings need not be haphazard and uninteresting. True, they may not be as exciting or inspiring as later meetings, but we should work on the principle that some activity is completed at every meeting, and something new is learned.

The Crew should be led to plan and execute some practical activities. Perhaps a ramble. How about repassing the Tenderfoot requirements? An industrial visit might be interesting. There is an endless list of possibilities into which the Rover Scout Leader can lead the members of his Crew.

For the first four or five months it is desirable to have members of the Crew read **Scouting for Boys** and **Rovering to Success**. At meetings, extracts may be re-read, and the Crew may be led to carry on a discussion to find out how what is written affects them in their daily lives.

## *Quest No. 6 — The Rover Scout Leader*

**Finding the Right Man** | Naturally, in the early stages of the formation of a new Crew it will be necessary to find and appoint a Rover Scout Leader. Also, Crews that have been in existence for some time may be unfortunate enough to lose their Rover Scout Leader, and it will become necessary to secure another. This is the responsibility of the Group Committee.

A well-tried method of choosing a new Leader is to have the Group Committee suggest that the young men who will become the nucleus of the Crew, in the case of a new Crew; or a Committee of the Crew, in the case of an existing Crew, submit a confidential list of men they would like to have as their future leader. The Group Committee can then go through the list with the Crew and, after approving a particular man, a small deputation consisting of perhaps one Group Committee member and two Rovers could make an appointment to see the prospective leader.

The Rover Scout Leader is appointed on the recommendation of the Group Committee, and approved by the Commissioner.

**Qualities and Qualifications** | The Selection of a leader must be made carefully. His age should normally be not less than thirty. Where a man of lesser age is being considered, his experience and understanding of his duties in relation to the age of the Crew must be taken into consideration. He must be a mature man, preferably married with children of his own. He must be a respected member of his community and one who is making a success of his own life.

A Rover Scout Leader must be acceptable to the members of the Crew.

In the past there has been a certain amount of misconception regarding the Rover Scout Leader and his duties. He has been looked upon as a genial old codger who sits back, takes a very small part in the deliberations or activities of the Crew and allows them to “run their own show”. How such a character can be called a Leader is hard to understand.

First of all, the Rover Scout Leader must be absolutely confirmed in his belief that the Scout Law and Promise teach principles of a way of life. He must be willing to subscribe personally to the Scout Promise. He must be prepared to stress this fact at all times and to see to it that the tone of the Crew reflects the fundamentals of Scouting. Real leadership is essential.

He must be a man who has had a considerable amount of experience in life, and by virtue of this experience be in a position whereby he can advise and guide his Rover Scouts, particularly, of course, when they are in trouble or doubt.



Technical skill in practical Scouting is an advantage, but not absolutely necessary; but he must read and study **Scouting for Boys** and **Rovering to Success**. Perhaps it should be said that he should continue to read and study those two volumes. B.-P.'s **Aids to Scoutmastership** is another book to read.

While it is good that he should allow the Rover Scouts to run their own Crew, he must advise them, suggest activities, warn them of difficulties, and encourage them when they come up against problems.

Above all he must continually be on the lookout for opportunities whereby the Rovers can render Service, and for means whereby they can train for Service. He must have the ability to make friends, particularly of course, with young men of Rover Scout age.

**His Place in the Crew** | The matter of the Rovers running their own Crew deserves some attention. Once the Crew has committed itself to any activities, and after the Rover Scout Leader has briefed them regarding possible difficulties and methods by which difficulties may be overcome, he should sit back and let them get on with it. It may be that he will have to submit to having his schemes rejected or overruled. He has to realize that Rover Scouts must learn and profit by experience. However, the Rover Scout Leader should know when to call a halt. But he also should see that once action has been taken, it is followed through to completion.

Like any leader, the Rover Scout Leader cannot be a "know-it-all", and he has to realize his limitations. When he feels that outside help is needed to train the Crew along certain lines he should not hesitate to obtain help from other people. This points to the need for the Rover Scout Leader to have a capacity for making friends with people who are outside of Scouting's orbit.

As Rover Scouting is a branch of Scouting, it should be apparent that he should love the outdoors and find delight in the world about him. He should have a keen appreciation that the world is full of things to marvel at and to investigate.

Above all, the Rover Scout Leader must enjoy his leadership and look on it as a happy adventure and be careful to see to it that at all times he sets an example of all that is meant by "Good Scouting".

His contacts with the Crew members must be frank and helpful, and he must work very closely with his Mates.

The Rover Scout Leader has been described as a guide, counsellor, and friend.

As a guide he must be able to show how life can be a rewarding experience when it is based upon a proper interpretation of the Scout Law and Promise as a code of daily living. A guide must know where he is leading and the road he proposes to follow, and also the methods he intends to adopt. In other words, he must have been over the trail beforehand. Thus, the Rover Scout Leader must experience what he advocates.

As a counsellor, a Rover Scout Leader must have calm judgement and practical wisdom. He must see life as a whole and attempt to lead his Rovers outward to the world as it is, with special stress upon opportunities that exist. There is no use in trying to turn Rover Scouting into a form of escapism or make it a barrier to reality.

As a friend, the Rover Scout Leader must remember that he will have friendship for the whole Crew and personal friendship for the individual. As a friend, the Rover Scout Leader is one to whom each Rover can turn, confident of the sympathy and understanding with his problem.



**Assistant Rover Scout Leader** | The selection of an Assistant Rover Scout Leader — if necessary because the Crew is very large — is very important. His qualifications are the same as for a Rover Scout Leader, except that the minimum age is twenty-five. An Assistant Rover Scout Leader must be able to work in harmony with the Rover Scout Leader, but at the same time he should have some different personal qualities so that, working as a team, they complement each other.

**Training and Resources** | To assist Rover Crew Scouters to better understand the art of leading their Crews, leadership training will prove of inestimable value.

There are many ways to receive training. Good books are one source and should not be underestimated.

Many institutions, colleges and community associations offer various types of training. These opportunities should not be overlooked.

The Boy Scouts Association also conducts many types of training courses and full details may be secured from your next senior Council.

Amongst the training opportunities offered by The Boy Scouts Association, Wood Badge Training is by far the most useful, and it should be the aim of every Rover Scout Leader to take this form of training. A pamphlet entitled “Your Personal Training Plan” is available through your local Headquarters, and we would also refer you to the book **Policy, Organization and Rules**, which every Scouter should own, and be familiar with.

The leadership of a Rover Crew is an outstanding challenge and a happy and rewarding experience. The trained leader can make the most of this opportunity.

## *Quest No. 7 — Teams and the Rover Mate*

**The Democratic Setting** | Scouting — Rover Scouting in particular — attempts to develop good citizenship. Good citizenship implies the ability of the individual to accept responsibility and to acknowledge the need to delegate some of his responsibilities to others as, for example, through the use of elected representatives at the local, provincial, and federal government levels.

A club, or even a gathering, must have some kind of organization and direction or else confusion reigns, and nothing is ever accomplished. Organization and leadership are necessary not only for the survival of the Crew, but also, for the proper training in citizenship that the Crew is supposed to give its members.

When Rover Scouting was first devised, the Patrol System, as applied to Boy Scout Troops, was thought to be the best method for organizing a Rover Crew. In practice this did not work out. Take another look at what has been written in Quest No. 3 concerning the make-up of young men. The reasons for the ineffectiveness of the Boy Scout Troop Patrol System are quite evident.

To achieve the desired training values it is essential to emulate the democratic setting in the organization of our Crew. The Crew must be run “for the Rovers, by the Rovers, and in the interest of the Rovers”.

**Teams** | In practice, it has been found advisable to divide large Crews into teams, of from four to six Rover Scouts, for ease of operation. The division of the Crew into such teams should be neither lasting nor arbitrary. They can form a useful working arrangement for general Crew activities, good turn projects, and camps.

**Elections** | For the regular Crew organization, the Crew will hold an annual meeting at which time a Rover Mate, and Assistant Rover Mates, if necessary, are elected by the Crew in consultation with the Rover Scout Leader. At this annual meeting there are elections for other offices, such as Secretary, Treasurer, Quartermaster, and other offices which the Crew might deem necessary.

For many reasons, every officer's responsibility and authority should be definitely determined. One who knows what is expected of him can plan his work and check up on his performance. He can fully use, but not over-step, the authority of his office.

This definite understanding is particularly important in a democratic group. Here every member shares in electing leaders and officers and also in serving as a leader or officer from time to time when elections roll around. A clear understanding by all members of the duties and powers connected with the various offices is a guide to intelligent voting in elections. It encourages members to give either their criticism or credit constructively. On the part of the leaders, it discourages two dangers to democracy — “passing the buck” on responsibilities, and assuming too much authority.

The provision for annual elections is a wise one. It enables the valuable training which a Mate and other officers receive to be spread over the entire Crew over a period of years.

**Function of Mates** | The Rover Mate has a considerable amount of responsibility on his shoulders. In a large Crew, it may be advisable to have one or two Assistant Rover Mates. He is expected to see that Crew activities are carried out through to completion, to give encouragement and advice to the Rovers in the Crew, and generally to see that the Crew is functioning properly. He is responsible for the business agenda of the Crew, and for the weekly programme of activities. He must be close to the Rover Scout

Leader, and the bond between the Mate and the Rover Scout Leader should be one of mutual trust and confidence.

The Rover Scout Leader should ensure that the Mate gets many opportunities to lead. This may well be his first chance of being a leader, and the experience he gains will stand him in good stead as a member of some community endeavour in the years to come.

The Rover Scout Leader has a real responsibility in giving advice to all Crew officers. Elected leaders do the best job when they welcome the counsel of their Rover Scout Leader.

No doubt the Crew Treasurer will welcome advice concerning the bookkeeping and banking necessary to keep the Crew's finances in order. It is amazing the number of men who go through life with only an elementary knowledge of keeping accounts.

If a Rover Scout likes detail work, the chances are he will make an efficient Scribe or Secretary. Regardless of personal likes, most young men can profit by the practice in record keeping and correspondence which the job involves. This will require the careful supervision of the Rover Scout Leader if it is to be done efficiently and, of course, the leader must keep in mind that it is sometimes detrimental to a person's well-being to push him into a job for which he is totally unsuited. Other duties, such as Quartermaster, should also be carefully assigned and assistance given to the Rover Scout by his Scouter in the initial stages of the appointment.

**Project Teams** | While the above-mentioned organization may serve a useful purpose for general activities, very often it will not prove to be suitable for some activities. For example, a Rover Crew with two Teams might have Rover Scout Jones in one Team and Rover Scouts Smith and Black in another. These three Rover Scouts may be interested in pursuing the Quest of Public Speaking. They should be allowed to form a Project Team to pursue their Quest. This type of "extra" organization within the regular Crew framework can serve a very useful purpose. After all, it is that way in life. You choose your friends with whom you wish to do amateur photography, and you probably have another set of friends with whom you play golf. It is quite natural.

The Project Team should be set up and authorized by the Crew Executive. Terms of reference and time limits should be set. When the project is completed, the leader of the Project Team should be expected to submit a report to the Crew, and when the report is accepted, the Project Team then ceases to exist.

### *Quest No. 8 — The Crew Executive and the Crew-in-Council*

**Democracy in Action** | The affairs of a large Rover Crew are controlled by a Crew Executive consisting of the Rover Scout Leader, his Assistants, the Mate and his Assistants, and such other Rovers or officers of the Crew as may from time to time be elected.

In this setting we have elected representatives making policy and determining activities for their constituents. The members of the Crew Executive are elected annually. In this way the Crew is given the opportunity to approve or disapprove of the way in which they have discharged their duties. This also produces the situation where the electors are willingly being led, accepting their share of the responsibility which goes with the privilege of being allowed to vote. This is democracy in action.

**Function** | The Crew Executive is responsible for conducting all the detailed business of the Crew. It is responsible for the control of funds, the acceptance and development of Good Turn projects, the development of Crew activities, the appointment of Sponsors to new Squires, Crew discipline and general Crew administration.

The Crew Executive uses the Scout Law as the basis upon which it conducts all its business and activities. This makes the Scout Law a living reality — a code of daily living.

One of the very important functions of the Crew Executive concerns the progress of individual Rovers. It must make certain that the new fellow is assigned a Sponsor or Sponsors from the moment he is accepted into the Crew on probation. At subsequent meetings of the Crew Executive there are reports from the Sponsors concerning the progress of the Rover Squire. If the progress is not satisfactory the Sponsors may be instructed to give the Squire additional help, and the Crew Executive should be prepared to give advice concerning how this can be done.

The Crew Executive also is responsible for seeing that each Rover Scout sets for himself a programme of self-development tied in with Training Stage activities. The Crew Executive will approve or disapprove of the individual's detailed programme and set a time limit within which the individual Rover must complete his Quest. When the time limit has expired the Rover will be expected to demonstrate how he has progressed on his Quest, and the Crew Executive will pass on the qualifications.

The Crew Executive is also responsible for arranging for older Rover Scouts to move on to the Service Stage.

The Crew Executive that operates efficiently, will make certain that some of its duties are delegated to Rovers who are not on the Crew Executive. For example, if a social or other Crew activity is being planned, the Crew Executive might appoint one of its members to head up a Committee to carry through with this activity. Members of the Crew may be added to this Committee to give them the opportunity to fully participate in all Crew activities.

**The Crew-in-Council** | The Crew-in-Council is a meeting of the whole Crew for the conduct of business. In small Crews the Crew Executive and the Crew-in-Council may be one and the same thing, i.e., there is no separate Crew Executive. In larger Crews the Crew-in-Council would meet infrequently; possibly once every quarter, but in any event at the annual meeting of the Crew.

Apart for the annual meeting of the Crew, the Crew-in-Council would meet only when major matters affecting the whole Crew have to be considered, and where the Crew Executive feels that the opinion of the entire Crew is desirable.

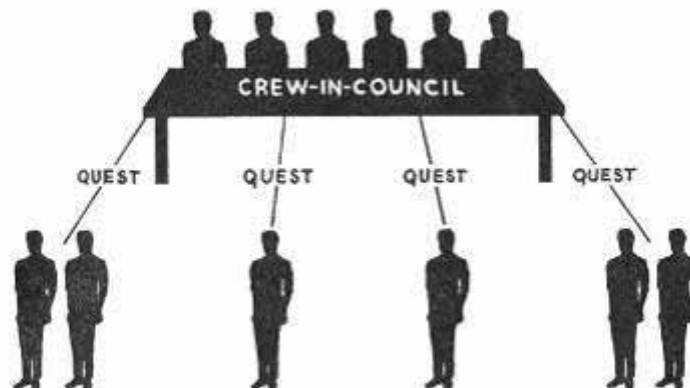



The Crew-in-Council would meet to consider the long range plans which the Crew Executive has developed. The main point to be considered would be the general scheme of things. The details must be left to the Crew Executive to work out.

Whether it is a Crew Executive or a Crew-in-Council meeting, the Rover Mate is in charge of the meeting.

It is very important to remember that the experience young men receive in assisting in the operation of their Crew along properly constituted lines is very valuable training since it represents the situation which will be repeated over and over again in their adult lives.

### *Quest No. 9 — The Rover Scout Den*

**Purpose** | A Rover Scout Crew needs a place wherein they can meet to accomplish the plans and endeavours in which they engage. Having an exclusive use of a Den gives the Crew a sense of belonging.

**Types** | While it may not be possible for a new Crew to obtain a Den right away, it should be their aim to have one as soon as possible. However, in the meantime the Crew may meet in the homes of the various members of the Crew. A box with portable equipment can be devised with a little ingenuity, and any living-room can be converted into a Den with a Rover atmosphere, in a very few moments.

All sorts of unlikely places have been made into Dens. For example, when one church changed their heating equipment from coal to oil, there was a large coal bin vacant. The Crew got permission without any difficulty, and converted the bin into a Den. The job called for an enormous amount of work to clean the bin after twenty years of storing coal, but the lads went to work with a will and some six months after taking over they had a very nice Den. They pointed with pride to the black oak rafters, which actually were pine wood, impregnated with coal dust.

Ancient garages have been used, as have odd corners in church basements, and there are some Dens which have been built entirely by Rovers. There is one Den built on church property which is liked so much by the authorities that the Vestry asked and received permission to hold their meetings in it.

**Facilities** | The Den should not be too large but should be reasonably comfortable. If there are no sanitary or cooking facilities to which the Crew has access the Den should include these amenities. If the Crew installs their own sanitation, they should take care to obtain a permit from the local health authorities. In fact, if a Crew decides to build a Den no matter where, a check with local building authorities must be made.

The furnishings of the Den need not be elaborate. Simplicity combined with comfort is all that is needed. It may be that, as soon as it is known that a Rover Scout Den is being built, offers of help will be made. These offers may include some provision of building materials and furniture. Some people may be ready to provide furniture, some of which may be ancient easy chairs or even davenport beds of equal vintage. It may be a bit awkward to refuse donations of this sort, but it must be kept in mind that the Den is a place to go from, as well as to go to, so that the furniture, while comfortable, should be utilitarian. Obviously the furniture for the Den should be selected on the basis of the amount of room available.

**Using the Den** | If a workshop space can be found close to the Den, so much the better, but if there is no such space available, the Crew should constantly be on the lookout for suitable workshop space. The

absence of a workshop, however, need not necessarily rule out handicrafts since the Den can be turned into a workshop for all sorts of projects.

**Decorating the Den** | Decorating a Den can be fun, and can be left to the Crew members. It is a good plan always to have some job that needs doing, so that every newcomer to the Crew has an opportunity to make a contribution to the Den. Unless all members of the Crew have had something to do with the construction or maintenance of the Den, they will take it all for granted, and they will have little or no pride of possession.

It has been known that in some places Crews have, at three or four year intervals, depending on the turnover of membership, made a clean sweep of the décor of the Den. They retain traditional features but as far as possible, create an entirely new decorative scheme.

There is an unique idea which embraces tradition and up-to-dateness. Each Rover Scout, after his Investiture, designs what he considers should be his coat-of-arms. This is painted on a wooden shield about eight inches across and ten inches long. This shield is hung on the wall of the Den, so that in time there will be a complete frieze of shields. When this happens, the Crew intends to have another row immediately below the original shields. This is an unusual way of keeping a record of membership, but part of the fun of Scouting lies in doing unusual things in an unusual manner.

One privilege of Crew membership should be the right of unrestricted entrance to the Den. As soon as a Squire has been invested, he should be given a key to the Den. Personal use of the Den provides a place where the Rover Scout can either pursue a hobby or study.

The Crew use the Den as dictated by their activities, but the Rover Scouts should be careful not to become Den-bound. The Den should be regarded as a base from which the members will set off on expeditions and Good Turns, just as much as being a place to meet for talks and discussions. It has been said quite frequently that Rover Scouts do too much talking and not enough doing. This may be so, but we must remember that it is natural for young men of Rover Scout age to talk — much of it small talk. While we have to accept this as natural the trick is to channel this tendency into useful directions. Here is where the Rover Scout Leader, the Mate, and the Service Stage Rovers can do a really sound job but, as has already been said, imagination is very necessary.

Naturally the Crew activities will affect the use of the Den, and so it is suggested that there be a sensible balance between projects conducted in the Den and those operated from the Den.

**Securing and Financing a Den** | Questions are sometimes asked about who secures and finances the Den. The securing of a meeting place for any phase of Scouting is the responsibility of the Sponsoring Institution. They generally delegate this responsibility to their Group Committee. However, Dens are not always easily acquired, and therefore the Rover Scouts themselves often co-operate with the Group Committee in obtaining suitable facilities.



Avoid a Den which is too large or which costs too much money to operate. Insist that the Den be clean and tidy at all times.

Before considering going into ownership of property, the Crew Executive and its Group Committee should read Rule 385 of **Policy, Organization and Rules**.

The current financing of a Den is quite rightly the responsibility of the Rover Scout Crew concerned. The objective of Rover Scouting is to turn out young citizens who will “paddle their own canoe”. The management of the Crew Den is valuable training for home management and ownership.

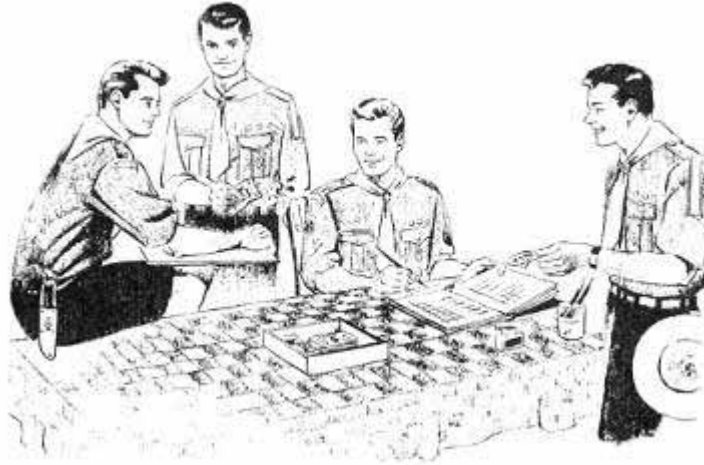

## CHAPTER FOUR

### ***The Rover Programme***

---

#### *Quest No. 10 — The Rover Scout Sponsor*

**Choice of Sponsor** | After a new fellow has joined the Crew and has been accepted as a Rover Squire, it is of the utmost importance that his initial training be taken seriously and completed in a thorough manner. While the responsibility rests upon the individual for his own training, he is assisted by two members of the Crew known as Rover Scout Sponsors.

Rover Scout Sponsors are usually appointed by the Crew Executive in consultation with the recruit. When a new fellow is accepted into the Crew and becomes a Rover Squire the Sponsors are formally assigned to him at that ceremony.

The choice of Sponsors is important. A scheme which has been quite successful is to have one chosen by the Crew and one chosen by the Squire. One of the Sponsors may be from the Service Stage. By the time a young man has passed through all the Stages of Rover Scouting he should have developed a broad experience in Rovering and a good understanding of its aims of citizenship and service, which fits him



admirably for the job of helping the Squire plot his course through the initial channels of membership in the Crew. That one of the Sponsors should be chosen by the Squire is common sense. He will most likely choose one who is a particular friend, or one to whom he has been attracted, and it is certain that he will be much more at home with a person he knows and admires, thus leading to a close bond which will be invaluable during and beyond the Probationary Stage.

Sponsors have an extremely important duty and responsibility, and the first question that comes to mind is what kind of fellows the Sponsors should be. In view of their job, it is surely agreed that they should have a keen appreciation of the ultimate aim of Rover Scouting as well as being experienced Rovers. It is not enough that they be competent in Scouting skills. If competence in Scouting skills was all that was needed then the Squire they are sponsoring would be nothing more than an apprentice.

It follows, therefore, that Sponsors must not only be competent Rover Scouts but wise mentors as well. Right from the start, they must be able to put the Squire at his ease and develop a spirit of comradeship between the Squire and themselves. First impressions are vitally important and, if the

Squire can be made to feel that in his Sponsors he has very real friends who understand him, he will feel at home in the Crew more quickly than if he were left to more or less bore his way in. It takes two to make a quarrel, and it also takes two to make a friendship. This is something that Sponsors should keep in mind at all times. They must make a real effort to cultivate the friendship of the Squire for whom they are responsible.

**Duties of Sponsors** | Please note the word “supervise” in relation to the Sponsor’s job. This indicates that Sponsors need not train the Squire in every detail of his probationary period, but rather see that as far as possible he trains himself and that, when necessary, certain parts of his training are handed over to others. For example, if there is in the Crew an expert in camping, the Sponsors would see to it that the Squire learns from the expert the techniques necessary to do a creditable job on the hike.

On the Squire’s qualifying hike he must cook and cater for himself and his companion. The best companion he can have is one of his Sponsors. If the Sponsor has established a bond of fellowship with the Squire, he will find he can break down reserve and get to know the Squire very well.

It is well to realize that in many instances the role of the Rover Scout Leader is a bit of a puzzle to the Squire, but with fellows of his own age the Squire is much more likely to open up and pose his problems with greater ease and less embarrassment. He may be worried about how he will be able to live up to the Law and Promise. In this case the Sponsor’s own experience will help to encourage him and no doubt show him something of the way ahead. His reading of **Rovering to Success** may recall to him a problem in his own personal life. Again, experience and sympathetic comradeship will help. The Squire may

even be worried about his ability to acquire the necessary Scouting knowledge. Any one of the foregoing can be a source of concern to the new Squire, and there are many other disturbing issues which he must face.

As already stated, the Squire is more likely to discuss them with the Sponsors but the proper approach must have been made by the Sponsors in the first instance. It will do no good to say to the Squire, "Now then, chum, let's talk about your problems". The Squire may be one of those reserved fellows who simply cannot open up his innermost thoughts to others, or he may be the type who dearly loves to talk about himself. In either case the Sponsor would be courting trouble by foisting himself upon the Squire. The approach must be more subtle — a casual reference to the Scout Law, over the meal or while sitting before the dying embers of a fire; some experience of Rover Scouting in action, told while hiking along; items of interest with the Crew itself; yarns about Scouting generally; invitations to the Squire to tell of some of his own experiences. All these are ways that may help to bring about a friendly exchange of experience useful to the Squire and Sponsor.

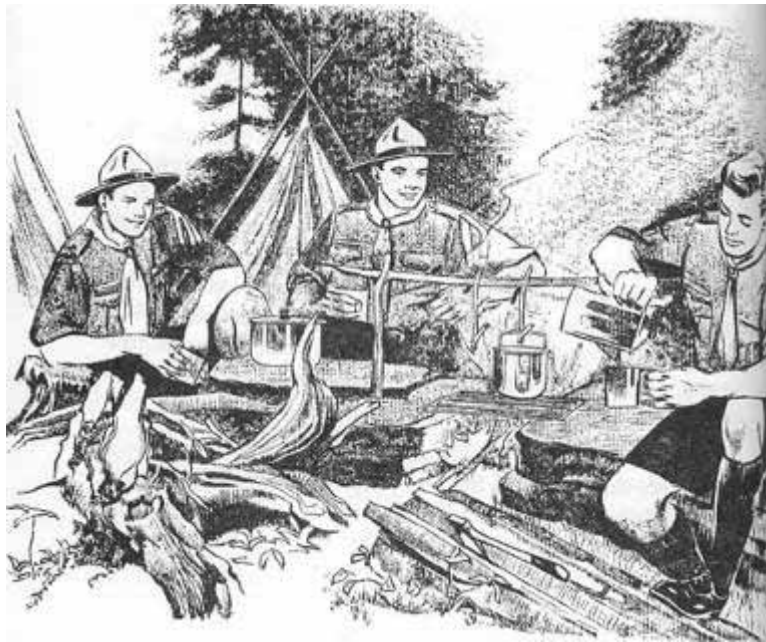

Not the least of the sponsor's duties is to make certain that the Squire fully understands what he is undertaking. The Squire must be completely aware of the implications of the Scout Law and Promise. It may be necessary to clear his mind of an idea that he is going to become a sort of "Super Scout", doing what he likes, where he likes, and when he likes. He may be under the delusion that he is joining a debating club, or he may imagine himself becoming a Sir Galahad and a very superior individual who will be a cut above the ordinary run of people.

These thoughts may be a bit exaggerated, but they will serve to point out what is meant by misconceptions of Rover Scouting. There is no more concise summing up of the principles of Roving than is to be found in the Investiture Ceremony as developed by Baden-Powell. Surely nothing can be more simply stated than, — "Are you, in spite of the difficulties you have had in the past, now determined to lead a clean life; to be honourable, truthful, and straight in all your dealings; clean in what you think about; clean in all you do; clean in what you say?" This, followed by the Rover Scout Leader's explanation of what is meant by service and a statement of the Crew's encouragement and assistance, sums up all that is implied in the term Rover Scout. In addition he should be charged to do his duty to his younger brothers, and to set them an example worthy of his best.

The Sponsors would do well to read the Vigil and Investiture with the Squire. As the Squire will undertake a man-sized job, it is only right that he should know what he is tackling.

Another thing which the Sponsors must determine is whether or not the Squire will fit into the Crew. If, in their opinion, there is some doubt, the Crew Executive and Rover Scout Leader should be consulted. The fact that the Squire does not seem compatible with other members of the Crew may not be entirely his own fault. It may well be necessary to help both the Squire and the Crew members to adjust to one another, or, if this proves impossible, and Rovering is still an attraction to the Squire, to help him “find himself” in another Crew. Failing this, the Sponsors might suggest other avenues of endeavour which may be helpful to the young man.

It must not be forgotten that the Sponsors present the Squire for Investiture. This means that they endorse his membership and undertake the responsibility of vouching for his suitability. This is not a matter to be taken lightly.

**The Sponsors and The Rover Scout Leader** | Apart from the fact that the Rover Squire is receiving valuable training, the Sponsors themselves are experiencing a tremendous training opportunity. It is a great responsibility to play a small part in the development of the character of any person. In effect, this is what Sponsors are doing. In other words, Sponsors are themselves receiving training by being Sponsors.

This situation requires careful guidance on the part of the Rover Scout Leader. It is more than likely that the Squire may pose problems which the Sponsors do not feel confident to tackle. The plan then is to refer the matter to the Rover Scout Leader.

Sponsors should also report periodically to the Rover Scout Leader concerning their sponsorship. This will give the Rover Scout Leader the opportunity to give counsel concerning their responsibilities. It may be that the Rover Scout Leader has found out a great deal about the background of the Squire which may have bearing upon the job of the Sponsors.

When several Squires are in training together, it may be desirable to organize a definite training programme with the Rover Scout Leader, or an Assistant Rover Scout Leader in charge and with the Sponsors assisting.

When the proper relationship between Sponsor and Squire exists, then an enthusiastic, prepared, young man joins the Crew. He knows why he is joining, and what to expect as a member of a Rover Scout Crew.

### *Quest No. 11 — The Rover Squire (The Probationary Stage)*

**Application** | Scouts, former Scouts, and non-Scouts may all seek admission to a Rover Crew.

Applications are usually considered by the Crew Executive, and the applicant should be notified of his acceptance without undue delay. It should be a very rare occurrence when an application is turned down. It must be for a very good reason, and the Rover Scout Leader must have the final say if that step is deemed necessary.

When an application is received from a fellow who is already in a Scout Troop the Rover Scout Leader should discuss the application with the Scoutmaster. Normally, advancement will be from the Troop to the Crew in the same Scout Group.

**Admission** | The admission of a Scout who has left the Troop and wishes to rejoin the Movement as a Rover Scout deserves special treatment. Once an applicant has been accepted, the Rover Scout Leader and Mate should make a point of reviewing the Tenderfoot requirements with him. At a meeting of the Crew the former Scout will be asked to reaffirm his Scout Promise in the presence of the Crew. Following this, he may be admitted to the Crew through the Acceptance Ceremony.

The non-Scout deserves another type of treatment. Once his application has been accepted, the Rover Scout Leader and Mate should assist him through the Tenderfoot Requirements and prepare him for Investiture into the World-wide Brotherhood of Scouts. When the recruit has passed the Tenderfoot requirements to the satisfaction of the Rover Scout Leader he is invested in the presence of the Crew, and subsequently admitted to the Crew through the Acceptance Ceremony.

In welcoming a fellow to the Crew, it is important that he be made to feel that he is really wanted as he may be a bit shy at first. This has been found particularly so with the young man who has never been a Scout. Being more or less suddenly set down in a group of young men, all of whom are probably older than he, and whom he has no doubt regarded as “Super-Scouts”, can be a bewildering experience. The appointment of the Sponsors, if wisely handled, will obviate this situation.

**The Training of a Squire** | The next thing is for the Squire to embark on his training. While the Sponsors will “supervise” this training, in the final analysis it is the responsibility of the Rover Scout Leader.

The first requirement of the Squire’s training is that he should read and study **Scouting for Boys** and **Rovering to Success**. Here is where the Sponsors should work closely with the Squire to see that he tackles the job in such a way that he really does understand these two books. A good deal of prompting and encouraging may be needed, and it is better to lead the Squire through the books rock by rock and chapter by chapter, rather than allow him to scan them. Since much of what the Crew will do is based upon these two books, they are of paramount importance.

There may be occasions when certain points may have to be clarified, or even argued. The Sponsors must be prepared with the proper interpretation, and may have to call upon the Rover Scout Leader for help.

It would be unwise to confine the study of these books to theory. Some of the practical elements in **Scouting for Boys** should be undertaken. Crew activities can provide good opportunities for the Squire’s study. From time to time the Crew may be embarking on a project which has a direct bearing on some portion of **Scouting for Boys** or **Rovering to Success**.

There may also be Crew discussions on some portions of these handbooks, and it is not necessary to stage the discussions deliberately. As a matter of fact, there is considerable value in these topics coming up as and when the occasion arises.

**Rovering to Success** | The question may be asked: “How or when can we be satisfied that the Squire has fulfilled the reading requirement?” First of all, it would be poor policy to determine whether or not the Squire has reached a satisfactory understanding by using any “examination” method. What is needed is to see that the Squire has arrived at a grasping of the underlying spirit of **Scouting for Boys** and **Rovering to Success** and that he is making a real attempt to put that spirit into action in his daily life.

This is the Sponsors' task, and it is their responsibility to ensure that the Squire is given every opportunity to discuss any difficulties he may have, and any problems which may arise.

The next requirement is that the Rover Scout understands and is living the Boy Scout Law and Promise as interpreted for Rover Scouts. Quest No. 31 in this handbook covers the implications of this requirement in detail.

**Sponsors** | It is the duty of the Sponsors to assist and advise the Rover Squire in his approach to the Promise and Law from the viewpoint of a man, and to ensure that he has a proper appreciation of their full import. The Sponsors should point out that the Scout Law and Promise form the basis of all Scouting, and that they are not a mere set of words, but are the hard core around which all Rover activities are built, and that living up to the Law and Promise is a real man's job.

**Scoutcraft** | Now we come to that portion of Rover Squire training which calls for Scoutcraft. The Squire is expected to undertake an eighteen-mile hike carrying his kit and sleeping in a tent, hut, or barn according to the season, for not less than one night, catering and cooking for himself and a companion. At the conclusion of this hike he will report to his Rover Scout Leader. In many cases, the Squire will have to approach this requirement gradually. Satisfactory skill in hiking and camping cannot be obtained overnight. It is much better that the Squire makes a number of hikes, starting out with one day ventures, covering a relatively short distance. Then, fortified by the experience and skill he has attained in the course of the preliminary runs, he can undertake his qualifying hike with confidence.

The Squire should be expected to keep a log of all his trips no matter how short or long the hikes may be. This log should be examined by the Sponsors and Rover Scout Leader from time to time.

A really high standard must be maintained. Rover Scouts will find a great personal satisfaction in setting a good example in all matters pertaining to camping and hiking.

The standard to be attained should be a matter for the Crew to determine, and it should be adjusted to the capabilities and personality of each Squire. Each of us is different, and what may be easy for one may be a bit difficult for another; so in fairness to all, credit for effort should be given. To a large extent, the Crew will have to accept the evaluation of the Sponsors. In this regard, one Sponsor should be the companion for the Squire on his qualifying hike in order that a fair appraisal may be made.

**Probation** | All of the above training is taken during the Probationary Stage of a Rover Squire. This Probationary Stage may be extended beyond the time needed to complete these activities, but should not be unduly protracted. The purpose of the Probationary Stage is to allow time in which the Rover Squire may prepare himself for Investiture, and to assure the Crew that he has attained certain standards of Scoutcraft, moral conduct, and "Scout Spirit".

From experience we know that it is not wise to establish a rigid time for the Probationary Stage. The time must be adjusted to suit the needs of the individual, taking into account his mental and physical standing.

It should not be forgotten that another purpose of the Probationary Stage is to determine whether the Squire will fit into Crew life, and whether the Crew will fit the needs of the Squire. He should be told right at the start of the Probationary Stage that if he finds Rover Scouting is not for him, he should discuss this with the Rover Scout Leader. On the other hand, if during his Probationary Stage the Crew feels he will not fit into their scheme of things, and after due consultation with the Rover Scout Leader, he will be asked to meet with the Rover Scout Leader. In either case, it will be the duty of the Rover Scout Leader to help the Squire adjust to the Crew and vice versa. If this is impossible, he should be encouraged to



continue his Roving in another Crew or in another field of endeavour. Normally the Probationary Stage will not go beyond six months.

During his term of Squireship, the young man should attend all meetings of the Crew and take part in all its activities. However, he should not be granted the privilege of holding offices in the Crew nor have a vote in Crew policy. He may have a say and participate in the planning and execution of Crew activities, as this will be part of his training to fit him into Crew life.

**“Joe-Jobs”** | Under no circumstances whatever should a Rover Squire be expected to do all the “Joe-Jobs” and menial tasks of the Crew. He should take his share of these jobs like any member of the Crew. To burden a new fellow with the unwanted jobs places the wrong emphasis upon the value of work, no matter how trivial.

**The Rover Scout Leader's Part** | While the Rover Squire is undergoing training the Rover Scout Leader has a real part to play, even though it is in the background. He should watch the behaviour of the Squire, and, if necessary, offer a few words of sound advice. For example, if it is noted that the Squire slips into the habit of using profanity when under stress, it is a sure indication that the Squire has not interpreted the Scout Law from the point of view of a man. Mature advice is needed. Similarly, the Rover Scout Leader may mentally compare the Squire's attitude to each part of the Scout Law. This will require deep reflection and contemplation on the part of the Rover Scout Leader, and he should plan his approach in consultation with the Sponsors for corrective measures, if needed, to suit the temperament of the individual.

The Rover Scout Leader should also expect periodic reports from the Sponsors regarding the progress of the protégé. It is suggested that at least two or three reports may be necessary, but in any event, a fairly complete report should be presented by the Sponsors to the Rover Scout Leader before the Squire undertakes his Vigil.

**The Vigil** | Before being invested, the Rover Squire subjects himself to a form of self-examination which we call his Vigil. The central idea is that a young man, before becoming a Rover Scout, shall quietly think out what he is doing with his life, and determine whether he is prepared to be invested as a Rover Scout making his Promise from the young man's point of view.

The Vigil of a Rover Scout may take any form, but the Founder, Baden-Powell, drew up a set of soul-searching questions which experience has shown us has a profound effect upon young men if the preparation for the Vigil has been seriously undertaken.

The following is the Vigil designed by the Founder, Lord Baden-Powell:

“As one grows older, time passes more and more quickly. Comparatively speaking, life only lasts for a short time and is soon away. Indeed, it may end tomorrow — even this night.

1. Am I making the best use of the life that God has given me?
2. Am I frittering it away, in doing nothing that counts — that is, wasting it?
3. Am I working at things that are not doing good to anybody?
4. Am I seeking too much my own enjoyment or money-making or promotion without trying to help other people?

5. Whom have I injured or hurt in my life? Can I do anything to make amends?
6. Whom have I helped in my life? Is there anyone else I can help?

“We get no pay or reward for doing service, but that makes us free men in doing it. We are not working for an employer but for God and our own conscience. This means that we are Men.

“The Rover Scout Branch of the Scout Movement is described as a “Brotherhood of Service”, so if we join it we will get the opportunity of training for and of doing service, in many ways that would not have been open to us otherwise.

“Service is not for spare time only. We must be constantly on the look-out for opportunities of serving at all times.

1. Am I joining the Rover Scouts only for the fun I can get out of it?
2. Am I determined to put real self-sacrificing Service into it?
3. What do I mean by Service?
4. Do I really think of others, rather than of myself, in my plans or undertakings?
5. What kind of Service am I best fitted to do?
  - (a) At home?
  - (b) In my spare time?
  - (c) At work?

“As the success of our Service will depend to a great extent on our personal character, we must discipline ourselves in order that we may be a good influence on others.

1. Am I determined to give up bad habits acquired in the past?
2. What are the weak points in my character?
3. Am I absolutely honourable, truthful and trustworthy?
4. Am I loyal to God and the Queen, my Country, my employers, those under me, the Scout Movement, my friends and myself?
5. Am I good-tempered, cheery, and kindly to others?
6. Am I sober and clean-living, and clean-speaking?
7. Have I pluck and patience to stick it out when things go against me?
8. Have I a mind of my own, or do I allow myself to be carried away by the persuasion of others?
9. Am I strong-minded enough to ward off temptation to drink, to harm a girl or a woman?
10. If I am weak in some of these things, do I resolve here and now, with God's help, to do my best to correct them and give them up?

“May God give me strength to go forward henceforth a real man, a true citizen, and a credit to my country.”

It should be made clear to the young man that he should not be invested and make his Promise until quite sure that he can honestly do so. He should think carefully before taking this important step and should not commit himself to a serious promise until resolved to do his best to keep it.

Scouting in all its branches is voluntary, and this cannot be made too clear to would-be Rover Scouts.

In his self-examination the young man reviews the past, thinks on future possibilities dimly seen, dedicates himself in silence to the service to God, and his fellow men. Without this, the Rover Scout Investiture cannot be what it is meant to be — an outward sign of an inward change of attitude to life in the world.

It is the Rover Scout Leader's responsibility to see that no young man joins the Rover Section of the Scout Brotherhood unless determined to shape his life in accord with the Rover Scout ideals.

Where, how, and when the Vigil is undertaken should be the choice of the Squire. He may choose to take his Vigil in his church, or out-of-doors. He will most likely choose a location which has some special significance to him. He may, or may not, have a companion. Again, he should be allowed to express his own desire.



Normally, a Squire should be able to complete this Vigil in one evening, but there are those who feel the need of an extra night or two. There is no hard and fast rule concerning this, and if by taking extra time the Squire is going to benefit by it, then by all means allow him to extend his Vigil.

In some cases, the Squire may wish to have the Rover Scout Leader accompany him to the place of the Vigil. The Rover Scout Leader could then retire, arrangements being made to see that there is no interruption, and so leave the young man to consider the questions for himself.

In any event, the Squire should let the Rover Scout Leader know when he is to take his Vigil, and the Rover Scout Leader should let it be known that he will remain available in case the Squire wishes to consult with him before, during, or after his Vigil.

Once the Rover Squire has completed the Squire's training to the satisfaction of the Rover Scout Leader and Crew, and has completed his Vigil to his own satisfaction, he will review his progress with his Sponsors, who in turn will report to the Rover Scout Leader. Following this, a time and place will be established for his Investiture.

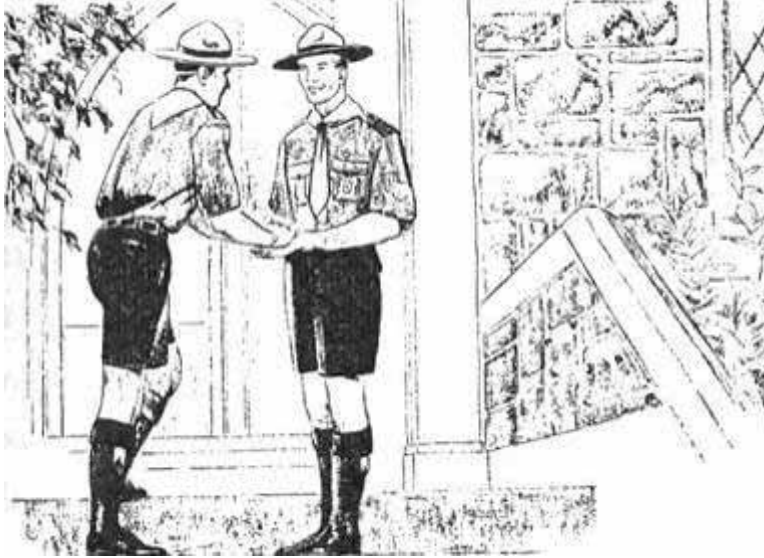

### *Quest No. 12 — The Rover Scout (The Training Stage)*

**Purpose** | Once the Rover Squire has been invested as a Rover Scout he is in the Training Stage. It cannot be too strongly emphasized that the primary task of Rover Scouting is to provide further training for the development of good citizenship by forming the character of young men.

Squire training has been the first step in this direction, but the Training Stage (Rover Scout) is the period during which the Rover Scout Leader may assist the individual to develop a personal programme of self-improvement which will have a lasting effect upon the character of the man.

The Training Stage really has four distinct purposes: —

1. The rounding off, and in some sense the completion of training in Scoutcraft, which in this case means camping, hiking, etc.
2. The broadening of the young man's vision; leading him to see what the world has to offer, in helping him to secure his lasting interest, vocational and avocational.
3. The giving of spiritual and moral strength to the Rover Scout, to effectively carry the Spirit of Scouting into the adult community.
4. The training of the young man for Service to the community both within and without the Scout Movement.

The Rover Crew where every member has exactly the same interests, does not necessarily mean it is succeeding. The bond of a Rover Crew should be brotherhood founded on the Scout Promise, and not founded upon uniformity of activity.

It is reasonable to expect that by the time a young man has reached twenty-one years of age he should have accomplished a great deal along the lines of self-improvement based upon the Quests he has undertaken. It is of the utmost importance that by this time he should have “found himself” so that he does know his capabilities, and where he is going in life. Now is the time to progress to the Service Stage.

**The Scheme of Training** | The training of a Rover Scout may be divided conveniently into two parts. The first part concerns the training of the individual as a part of the Crew, and the second concerns the training of the individual apart from the Crew.

The details of the training of the Rover Scout in the Crew setting will not be dealt with here. Suffice it to say that individual training in the Crew concerns principles and activities which are common to the whole Crew. By principles we mean the promise of Duty to God, the promise of Duty to the Queen, the promise of Duty to neighbour, and the promise of obedience to the Scout Law. By activities we mean the things which the Crew does together. This phase of Rover Scout training will be dealt with in a subsequent chapter.

It has been said that there is no Rover Scout “programme”. This is quite true if we are thinking in terms of all Rovers in the country, following the same set of prescribed activities. However, there is a programme for the individual Rover. This programme includes the activities which he will pursue on his own, or in company with one or two friends. Broadly speaking the Crew activities are common to all Rover Scouting, and all Rover Scouts in the world participate in them, but the individual activities vary according to individual needs and inclinations. In other words, at any given moment every Rover Scout is following two different sets of activities; his personal activity and the Crew activity which make up *his* programme.

**Scheme of Individual Training** | After Investiture, the Rover Scout will undergo training, choosing his individual activities from a wide range of subjects. The subjects, or Quests as they are called, should be chosen with a view towards the development of the individual's mental, spiritual, and physical powers. They include vocational and avocational pursuits, cultural subjects, Scoutcraft, handicraft, sports, and citizenship studies and activities. The Rover aims at progressive development in whatever he chooses, and over a three or four year period he could complete eight or nine subjects.

The first point to make is that there is no scheme of tests, examinations, or badges except the Rambler Badge and the Progress Thong.



Once a Rover Scout has chosen a subject he wishes to pursue for the next five or six months, he is expected to outline what he hopes to achieve and how he will accomplish it. These self-set "requirements" are submitted to the Rover Scout Leader and Crew-in-Council before the Rover Scout embarks upon his Quest, and the requirements are either approved, or modified and approved, for the Rover Scout. It is important to establish challenging, but attainable, standards.

**Rover Scout Leader's Part** | Once the Rover Scout has embarked upon a Quest, the Rover Scout Leader has a vital function in this part of the Rover's training. He must keep his eye on the Rover's progress, give him encouragement and advice when necessary, and see that the Crew activities and obligations are not so demanding upon the individual's time that he cannot possibly go forward along his own trail. Furthermore, if the individual is not making progress in his chosen Quest, it may be necessary for the Rover Scout Leader to review with the Rover the standards and methods which were approved by the Crew. Perhaps the individual has bitten off more than he can chew. In any event, whenever a Quest is undertaken it is essential to bring it to a conclusion, even though incomplete, as long as the individual has done the job to the best of his ability.

Incomplete Quests should not be looked upon as failures. Rather, there should be an attempt to draw useful conclusions from the experience. Thus, the individual can be led to understand his own capabilities and talents. He begins to understand himself — his weaknesses and his strong points. Personal coaching of this sort requires very careful thought and planning on the part of the Rover Scout Leader.

It may be that a Rover Scout will commit himself to a Quest, and then do nothing about it. When this situation arises, the Rover Scout Leader should make an attempt to find out why the Quest has not been completed. It may be that the Rover Scout has not fully realized the opportunity he has had to develop his own character and abilities in a Quest. Perhaps he is content just to take part in Crew activities. If this is the case, he is taking advantage of only half of what Rovering has to offer him. The Rover Scout Leader should try to guide the young man and encourage him to complete his chosen Quest.

**The Crew's Part** | The Rover Crew also plays a part in encouraging the Rover Scout with his Quest. The Crew must see that opportunities are available for self-training and that a periodical check is made on each member's progress. Rovers in the Service Stage can be of immense help to younger members who are in training. Their advice should be sought by Rovers in training, when problems are encountered.

To work with a friend on a project is much more fun and much more interesting than to play the lone wolf. In larger Crews it is quite understandable that a Rover and his friend, or a small section of the Crew may wish to pursue the same Quest, or Quests that are similar. "Workshop parties" for this purpose should be encouraged where possible and desirable.

When does a Rover Scout complete his quest? Well, during his training period he will keep charts and logs, pictures and drawings, samples and specimens, or anything that will help him give a talk or demonstration of what he has found on his Quest. At a regular meeting of the Rover Crew, the Crew will assign twenty minutes to an hour (or as much time as may be necessary) to allow the Rover to demonstrate his knowledge.

It is most difficult to set down any rules or regulations to determine when, or if, the Rover Scout has completed his Quest to the point where it is considered satisfactory. There are a number of factors to be considered. There is the mental capacity of the Rover; there are the opportunities which may, or may not, be present to help him with his Quest. Furthermore, comparisons are odious. To compare one Rover's efforts with another, in a given endeavour, is not desirable, as it does not test either individual's abilities. The main thing is to give credit for the effort put into the Quest to the limit of his ability, the time he has

at his disposal and the resources available to him. It is the duty of the Crew-in-Council to judge whether or not the Progress Thong should be granted. By the time a Rover Scout has pursued his choice to the point where it can be established whether or not he deserves the honour of a Progress Thong, his enthusiasm and capabilities should be well known to his fellows and his Rover Scout Leader, and so the Crew should be able to assess his efforts.

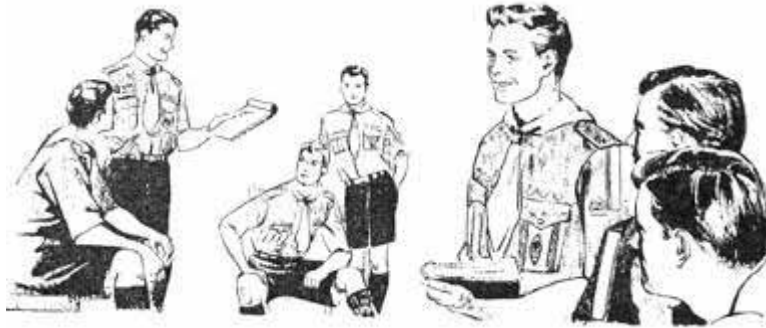

Of course, the Crew will guard with zeal its good name and reputation in establishing standards, but these standards cannot be set out in exact terms. They are arbitrary but, if the Crew bears in mind that enthusiasm and a degree of dedication to the job, plus a practical approach, are wanted, it should not be too difficult to arrive at an honest decision.

From the foregoing it will be obvious that an outside examiner is not in a position to judge, although his advice could be sought in conjunction with any technical details connected with the Quest.

**Basic Training** | Training in Scoutcraft and training for Service are considered formal basic training for every Rover Scout. In addition, each Rover Scout will pursue his own chosen Quest.

As Rover Scouts are a “Brotherhood of the Open Air” they should train towards a very high standard of camping and hiking. Because they are a “Brotherhood of Service” they should train for efficient Service. In this regard it is imperative to recruit the help of other organizations who specialize in this type of training. For example, the St. John Ambulance will assist with First Aid training. The local Civil Defence Organization or local Militia regiment will give training for preparedness in time of disaster. The Royal Life Saving Society will teach lifesaving. The Canadian Red Cross will help with water safety. Use the resources of your community.

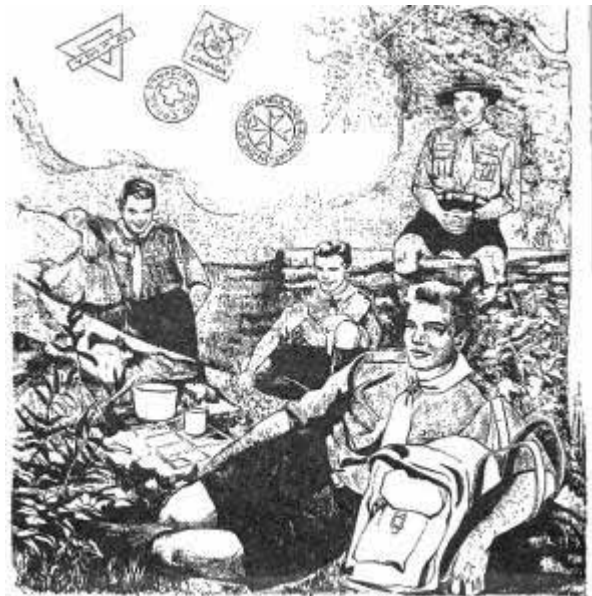

### *Quest No. 13 — The Service Rover (The Service Stage)*

**The Purpose** | The purpose of the Service Stage in Rover Scouting is to provide the opportunity for trained Rover Scouts to carry the Scout Spirit into the community, and to offer trained service in diverse ways, according to the talents and skills of the individual. It allows the trained Rover a year or two of extra membership in the Crew during which time he is expected to take on new responsibilities in the community. He is transferring from the “getting stage” of life to the “giving stage”. While he is doing this he is still privileged to call upon his Rover Scout Leader for personal advice if he runs into snags while taking his part in the community.

**The Time To Move On** | Inevitably the question “When has a Rover Scout completed his Training Stage?” will arise. Naturally, this would depend upon the individual concerned. However, it is reasonable to expect that the young man of average intelligence will move on to the Service Stage somewhere around, but not later than, his twenty-first birthday. The Rover Scout Leader must give strong leadership to direct Rover Scouts who have reached maturity into the Service Stage, or else there may be a tendency to become a “hanger-on”.

It must be recognized that some Rover Scouts will not be able to take advantage of what the Rover Crew has to offer because of employment conditions, home conditions, school studies, and a multitude of other causes. Rovers in this category should be directed towards the Service Stage, so that their uncertain attendance at Crew activities will not hamper the activities and plans of the more active Rovers.

Likewise, Rover Scouts who have become Scouters while still of Rover Scout age should be directed to the Service Stage, so that there will not be any demands on their time which will interfere with their functions as Scouters. This is important.

Rover Scouts who have completed the Training Stage to the satisfaction of the Rover Scout Leader and Crew pass to the Service Stage, at which time they are expected to be available for any Service Projects and other activities undertaken by the Crew. However, it is well to remind ourselves that Rover Scouts in the Service Stage will not participate in the development of programme and policy of the Crew, although they may be called upon for advice.

**Conditions** | If a Rover Crew has been successful, experience indicates that certain dangers may exist when a Crew retains a large number of men in the Service Stage. As *esprit de corps* is largely responsible for success these older Rovers will naturally want to continue their association. They have had, and are still having, an enjoyable experience. However, they must realize that the affairs of the Crew are the business of the Rovers in the Training Stage, and they must refrain from interfering. They will probably see some of their pet schemes and traditions radically changed, but if they are able to accept these changes it is a sure sign that they themselves are maturing.

A large number of Service Stage Rovers may tend to turn the Crew into a social club, or a Scouters' club. There is no room for this type of organization within the structure of the Rover Crew.

Rovers in the Service Stage must be an example of what Rovering can do for young men. Church and home life must be exemplary, business relationships must be above reproach, and willingness to continue to learn must be in evidence. Above all, the members of the Crew in the Service Stage must be a pattern of happy, healthy, useful citizens. They must represent all that is best in Rovering.

As Rover Scouting is a programme of training, it stands to reason that eventually the time will arrive when a young man has “found himself” and will need to take leave of the Crew. This should be a matter



of rejoicing because it means that one of the members of the Crew knows where he is going, what he is going to do with his life — in other words he is finding success and in doing so the Crew itself is successful. The aim of Scouting has been achieved. It may be, however, that a Rover Scout reaches the upper age limit of twenty-three and has not “found himself”. If this occurs, it is imperative that the upper age limit be enforced and that the young man be encouraged to look elsewhere for further development.

CHAPTER FIVE

## **Ceremonies**

---

### *Quest No. 14 — Progressive Rovering*

Since the beginning of recorded history ceremonies have played a very important part in the lives of men. History and literature contain many descriptions of ceremonies. The more ancient are steeped in tradition, and are beautiful to watch. Some are secret, some are allegorical, but whatever their form, ceremonies have been developed for a purpose. Of course, there are exceptions. We find travesties of the word “ceremony” where show and spectacle supplant the original purpose of the ceremony.



In Rover Scouting we must interpret the meaning of the word “ceremony” as “the behaviour regulated by the laws of strict personal discipline and self control of the individual”. In other words, by having participated in a Rover Scout ceremony, the individual participating must so discipline himself and exercise self-control by following the obligations he has undertaken, that he will be a better man for it.

This leads to the next point regarding Rover Scout ceremonies. Sincerity is the key note. Coupled with sincerity must go shortness and simplicity. In the past, many Crews have attempted to elaborate on ceremonies, particularly the Investiture of a Rover Scout, to the point where the central theme, the real meaning of the ceremony, has become obscured. Furthermore, many of these ceremonies have been copies from other organizations where the symbolism has very deep meaning, but where it becomes a mockery when used by a Rover Crew.

The reader will note that the Vigil of a Rover Scout is not described in this Quest. There is a good reason for this. The Vigil is not a ceremony; it is a requirement for Investiture.

There is great value, particularly in a Brotherhood, in having ceremonies which are common to all Rover Crews. The following ceremonies will be found adequate to deal with the various situations as a young man progresses through Rover Scouting.

**Prayers and Religious Symbolism at Ceremonies** | Great care must be exercised in introducing prayers and religious symbolism at Rover ceremonies.

Where a Rover Crew and its Leader are all members of one religious denomination no problem really exists. In this case it is strongly recommended that the Crew consult with their chaplain to develop a religious content to their ceremonies. In this way many beautiful and deeply significant aspects of Crew ceremonial may be introduced.

On the other hand, Crews whose members come from various religions and denominations must strictly abide by the religious policy of The Boy Scouts Association. We must keep in mind that there are certain religions that forbid their members to worship in company with members of another religion. Therefore, anything more than Scout silence could be an affront to an individual's belief. We are not only obliged to respect the individual's beliefs, but also to respect his obligations. There may be instances when an individual will say, "Oh, it doesn't matter", and even his religious advisor may give offhand approval. However, if we sincerely believe that our task is to help the individual to firmly establish himself in his religious life we would be doing him a disservice, and encouraging him to become a weak member or an "unbelieving" member of his church if we did not draw to his attention his religious obligations.

This view may be difficult for some individual Rover Scout Leaders to take in their stride on the grounds that Scouting is inter-denominational. However, we are inter-denominational because we take this view — otherwise we would be non-denominational. If we were non-denominational there would be no individual religious basis for Rover Scouting, and what we profess would be an hypocrisy.

**The Advancement and Acceptance Ceremony (Scout Troop to Rover Crew)** | The Troop is in horseshoe formation and the Crew is lined up across the open end of the Troop formation. If there are sufficient Rovers it may be desirable for the Crew to form a horseshoe with the open ends of the Troop and Crew horseshoes facing each other. The Scoutmaster is in the open end of the Troop formation, and the Rover Scout Leader is two steps ahead of the Crew line, or, in the open end of the Crew horseshoe.

The Scoutmaster opens the proceedings by explaining the purpose of the gathering. Mention will be made of the fact that it is every Scout's aim to advance to the Rover Scout Crew.

The Scoutmaster calls forward the Scout who is advancing to the Crew, and briefly reviews his record in the Troop.

The Scout reaffirms his Scout Promise.

The Scoutmaster now introduces the Scout to the Rover Scout Leader and advances the Scout to the Crew. The Scoutmaster retires, and the Rover Scout Leader officially welcomes him.

The Rover Scout Leader then says something similar to the following: "As you know, Rover Scouts are expected to adopt certain principles which will guide them along the Rover trail. These principles are:—

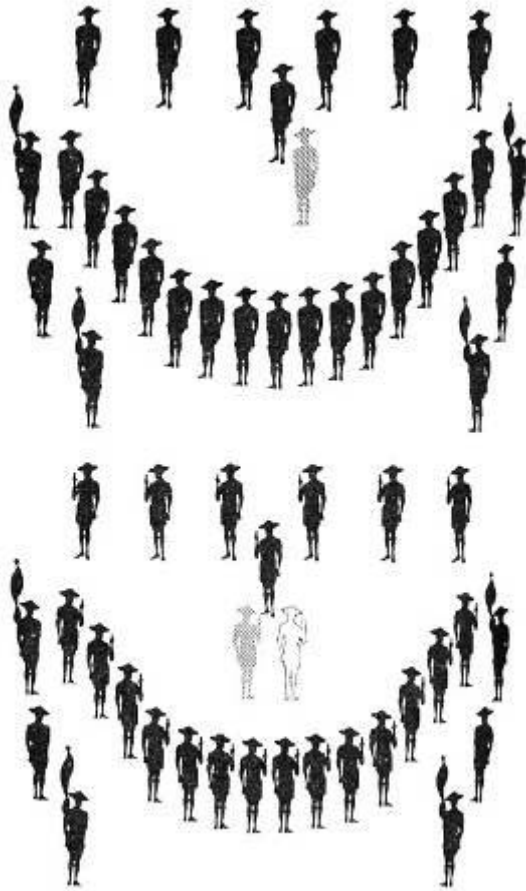

ADVANCEMENT CEREMONY—TOP TO BOTTOM

“Your promise to do your duty to God, by developing your own spiritual life, and by practising your own religion;

“Your promise to do your duty to your Queen by preparing yourself to become a good citizen of your country;

“Your promise to do your duty to your Neighbour by training yourself for service to others, and preparing yourself for useful employment;

“Your promise to obey the Scout Law, remembering that you must now look upon it from a young man’s viewpoint.”

“Are you willing to adopt these principles?”

The Scout says, “Yes sir, I am.”

The Rover Scout Leader will then welcome the young man to the Crew and to Rover Scouting, reminding the new Squire that Rover Scouting is a Brotherhood of the Open Air and Service. The Rover Scout Leader pins on the Rover Squire’s Shoulder Knot and says, “I now turn you over to your two Sponsors who will supervise your Rover Training in preparation for your Investiture as a Rover Scout.”

The Sponsors are formally introduced and take charge of the new Rover Squire by immediately introducing him to all of the members of the Crew who congratulate him upon his Advancement.

This ceremony may close with any Troop and Crew yells or songs which are traditional.

**The Acceptance Ceremony (becoming a Squire)** | When a young man joins a Crew without advancing directly from a Troop to the Crew some formal type of Acceptance Ceremony to mark the occasion is necessary. Following the Scout Investiture of the non-Scout, or the reaffirmation of the Scout Promise by the former Scout, the Rover Scout Leader will immediately conduct the Acceptance Ceremony. This will take the form of the Advancement Ceremony from the point where the Scoutmaster retires, and the Rover Scout Leader takes over.

**The Investiture Ceremony of a Rover Scout (becoming a Rover Scout)** | One could do no better than follow the ceremony as developed by Baden-Powell.

NOTE: — The Investiture as outlined by the Founder is printed in full. If it is not desired to use the ceremonial parts, the portions printed in **bold face** may be omitted.

The young man, after self-examination, is brought before the Rover Scout Crew, the Crew being in uniform, **and stands with his two Sponsors, one on either side, before a table, which is covered with a St. Georges Cross, upon which is set a ewer of water, a basin, and napkin.** The Rover Scout Leader stands facing them **behind the table**, and calling the candidate by name, says:

Leader: "Have you come with a desire to become a Rover Scout in our World-Wide Brotherhood?"

Candidate: "I have."

Leader: "In spite of the difficulties you have had in the past, are you now determined to do your best to lead a clean life; to be honourable, truthful, and straight in all your dealings; clean in what you think; in what you say; in all that you do?"

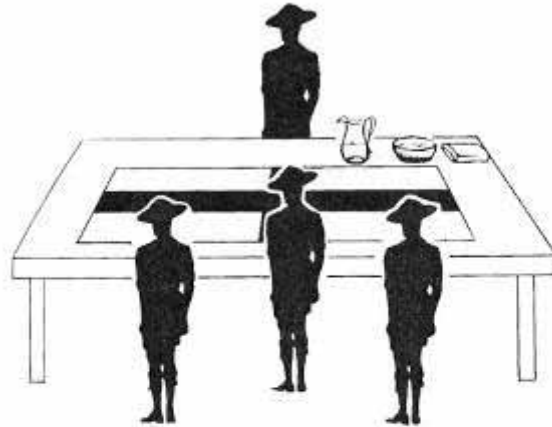

Candidate: "I am."

Leader: "Have you carefully thought what you are doing with your life?"



Candidate: "I have."

Leader: "Do you understand that Service means that at all time you will be good-natured towards all other people, and will do your best to help them, even though it may not be convenient or pleasant to you, and that you will expect no reward for so doing?"

INVESTITURE CEREMONY

Candidate: "I do."

Leader: "Do you understand that by becoming a Rover Scout you are joining a Brotherhood in which we want to help you carry out your ideals, and in which we ask you to obey our Rules and carry out our motto of Service for others?"

Candidate: "I do."

**Leader: "In ancient times it was the custom of those about to become Knights to be laved with water, in token of the washing away of past misdeeds and as a sign that they were determined to commence afresh. Are you willing to give such a sign, here in the presence of us all?"**

**Candidate: "I am."**

**(The candidate, or if more than one, each in turn, thereupon places his hands together over the basin; one Sponsor takes the ewer and pours water over them, while the other takes the napkin and dries the candidate's hands.)**

Leader: "Understanding these things then, I ask you to renew your Scout Promise, bearing in mind that you are expected to interpret it not from a boy's point of view, but from that of a man."

(The candidate advances, and at the same time the Rover Mate steps forward with the Crew Flag in his hands and lowers it between the Rover Scout Leader and the candidate, who takes hold of the Flag with his left hand and makes the Scout Sign with his right. The Crew makes the Scout Sign.)

Candidate: “On my honour, I promise that I will do my best —  
To do my duty to God and the Queen,  
To help other people at all times,  
To obey the Scout Law.”

The Rover Scout Leader then takes the new Rover Scout by the left hand **and gives him a buffet on the left shoulder with the right hand, saying:**

Leader: “I trust you on your honour to continue to keep your Promise **and give you the buffet which the Knights of old received to remind you, as it did them, that you have one tender point, namely, your Honour: nothing should be more quickly felt than an imputation against it.**”

After which the Rover Scout Leader then fastens on the new Rover Scout's shoulder knot and presents him with his badges, saying:

Leader: “In this shoulder knot of yellow, green, and red you see the representative colours of the three Sections of our Brotherhood — let it remind you of your duty to your younger brothers, and of your responsibility as a Rover Scout, to set then at all times an example worthy of your best self.”

(The Crew close in round the new Rover Scout, shaking him by the hand and giving him a welcome.)

The Investiture should never be held in public; it is a solemn exercise of the Crew's corporate life. The Ceremony may be held in a church or chapel, in the open air, or in the Rover Scout Den. If it is held in the Rover Scout Den it has been found that it comes best at the end of an evening's programme.

A fitting close to the Investiture is to finish with prayers, provided prayers can be said by the whole Crew without conflicting with any individual's religious beliefs. Suitable prayers may be found in the book **Prayers for Use in the Brotherhood of Scouts.**

**Progress Thong Presentation** | When a young man has completed a Quest to the satisfaction of the Rover Crew and the Rover Scout Leader, it is proper that due recognition be given of this achievement for the satisfaction of the individual concerned and for the encouragement of the other members of the Crew.

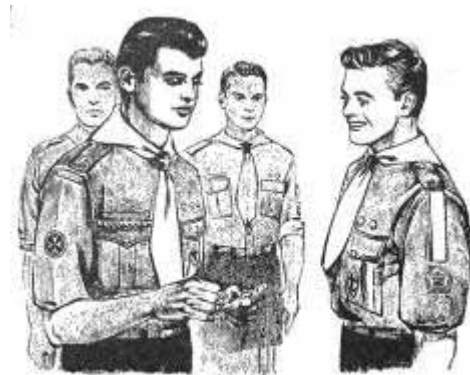

PROGRESS THONG PRESENTATION

At a regular meeting of the Rover Crew, the Rover Scout concerned will present his Thong with the Diamond Knot (or Knots) in it to the Rover Scout Leader, who will briefly outline the accomplishments which it represents. Following this, the Rover Scout Leader will call the Rover Scout forward, and formally present his Thong to him. There must be a note of challenge for further endeavour in the Rover Scout Leader's closing remarks.

**The Service Stage Ceremony (progressing to the Service Stage)** | When a Rover Scout is ready to move on to the Service Stage for any of the reasons outlined in the chapter on this subject, it is desirable to mark the occasion by a suitable observance. In this way, the Rover, as well as all concerned, will know that he will now occupy a new position in the Rover Crew and that some Rover Scout obligations and privileges will be lost, but other obligations and privileges will be assumed.

The Rover Scout Leader will call the Rover Scout before the Crew, and briefly remind the Rover Scout that in passing to the Service Stage he will no longer participate in the formulation of Crew policy and that he may no longer hold an office in the Crew. At the same time he may continue to enjoy the fellowship of his fellow Rovers, participate in Crew activities, and still enjoy the benefits of his Rover Scout Leader's counsel and guidance as he actively goes into the community to seek opportunities for service.

**Leave-Taking Ceremony (leaving the Crew)** | At any time between the Investiture and his twenty-third birthday a young man will leave the Crew. Upon reaching twenty-three years of age it becomes obligatory for the Rover Scout to leave the Crew. Whatever the reason for leaving the Rover Crew, it is highly desirable to make a clean and formal break in a dignified manner, and this is best accomplished by means of a brief ceremony.

The Rover Scout Leader will open the proceedings with a few appropriate remarks. The Crew will be reminded that the aim of Rover Scouting is to help young men to become happy, healthful, useful citizens, and that one of their number has reached the point where he feels that he can go out on his own, confident that he has achieved that aim.

The Rover Scout Leader will call the Rover Scout forward and say, "Do you understand that in taking leave of the Rover Crew you take with you the obligations of living up to the Scout Law and Promise and promoting these principles into the community?"

The Rover Scout says: "Yes sir, I do."

The Rover Scout Leader will then say: "Do you also understand that you are obligated to carry the Rover motto of Service with you as you leave the Crew?"

The Rover Scout says: "I do."

The Rover Scout Leader asks: "This being your desire, I now ask you to reaffirm your Scout Promise."

The Rover Scout reaffirms his promise. Following this, the Rover Scout Leader will make a few well-chosen challenging remarks and wish the young man God-speed and good luck in the name of the Crew.

It should be kept in mind that when a young man takes leave of the Crew it should be a happy occasion. Therefore, it would be quite appropriate to have a farewell dinner to conclude the evening.

**Opening and Closing Ceremonies** | At all Crew gatherings it is desirable to have an opening and a closing ceremony. This serves a very valuable purpose if only to mark the beginning and end of a meeting. However, it should serve a more useful purpose than this. As has been stated before, a ceremony may be designed to regulate the behaviour of individuals within the Crew. Opening exercises can set the atmosphere for whatever type of meeting or activity is to follow. A closing ceremony should be conducted at the conclusion of the activities period of a meeting, and before the social part of the evening begins. This marks the point in the evening when anyone is free to leave the meeting to go about their business elsewhere if necessary.

Rover Crews should feel free to develop opening and closing ceremonies based upon their own needs and traditions. However, it is a mistake to simply copy some elaborate ritual from another Crew or organization “just because it looks nice”.

Here are a few suggestions which may form the basis for further elaboration built around Crew tradition.

Whether it be an indoor or an outdoor meeting it is good practice to hold flagbreak. This is symbolic of our duty to our Queen and country. Some form of short devotional may also take place, symbolic of our duty to God. This may then be followed by some act symbolic of the Brotherhood of Rover Scouting. This may be accomplished by various forms of ceremonies. For example, some Crews light red, green, and yellow candles, symbolic of the three Sections of the Scout Movement and of the three parts of the Scout Promise.

Another idea, particularly if a business meeting is to follow, is to bring in a thumbstick as a symbol of Rover Scouting and lay it on the Mate's table to indicate that the Crew is in session and is ready to conduct its business.

Still another idea is to take a section of the Scout Law each week, repeat it and have one of the members, in his own words, elaborate upon its meaning.

The closing ceremony usually follows the reverse order of the opening. Some Crews make a practice of periodically reaffirming their Scout Promise before dismissal.

## CHAPTER SIX

### ***Crew Meetings***

---

#### *Quest No. 15 — In the Den*

As we have said, a Rover Scout Den is a place wherein Rovers can meet to accomplish the plans and endeavours in which they engage. While this is the prime purpose of the Den, it may also be utilized as a place in which valuable training can be imparted to the members of the Crew.

**Principles** | If we are to avoid aimless wandering and unnecessary nattering at Crew meetings in the Den it is essential to establish some pattern of procedure. The measure of success of any meeting may be determined if three conditions are met. First of all, everyone should participate. Secondly, everyone should leave the meeting wiser for having been there. Thirdly, it must be an enjoyable experience.

It is often difficult to get everyone to participate. This may sometimes be due to a member who has a dominating personality. Another may be reticent. Yet another may be a constant griper. And then there is the know-it-all whose word is final. There are other personalities which you will meet, but regardless of the type, the Rover Scout Leader, working through the Rover Scout Mate, must see to it that everyone has a fair share in participating in Crew meetings. By tactful and diplomatic discretion, each person



should learn to become a working member of the team. This lies close to the root of the real job of the Rover Scout Leader.

If everyone is to leave the meeting wiser than when he came, it is obvious that some form of instruction must be on the agenda. Learning is an active process and therefore practical activity supplemented by yarns or discussions must be keynote. Please note, talks and discussions supplement activity, and it is not activities which supplement verbal instruction. Of course, there are some subjects (which should be kept to a minimum) whose very nature makes it difficult to combine them with a practical activity. However, by using a little imagination, it is usually possible to devise some sort of activity around any subject.

For example, a Crew may decide to study the subject of etiquette. "Manners maketh the man", and therefore this is a subject suitable for young men. We could talk about the subject until we were blue in the face, and while we might put across some points merely by talking, we would make a more indelible impression upon the learners if we were to use some good teaching techniques. The simple problem of how you introduce a lady to a lady, a gentleman to a lady, and elderly gentleman and his wife to a young girl, and the endless variations on this subject could be taught by acting through the parts. What to do with your serviette, and what item of silverware you use with

each course may also be dramatized. How you carve a turkey, a goose, or a chicken at the table if you were the head of a family also presents an interesting situation. You do it differently for each fowl, you know! Why not prepare a full course meal, and go through the whole routine? Of course, you'll eat the food.

Enjoyment of the evening is all important to the Rovers themselves. They must have fun. This would indicate the desirability of having stunts, games, and some physical activities on the agenda. Indoor home games such as table tennis are suitable forms of recreation, but avoid the danger of overdoing one form of activity.

Observation games are excellent forms of training and are a lot of fun. Here are some suggestions. Remember, they must be kept on a more advanced level than that of the Boy Scout Troop.

Rovers are blindfolded and they listen to, and try to identify a series of noises. For example, pumping a tire, striking a match, bouncing a ball, pouring water, tearing paper, etc., — you can think of a dozen other things.

Each Rover handles a series of bags and tries to identify various objects (cork, keys, beads, coins, etc.) or substances, (gravel, tea, lump sugar, sand) inside.



In the dark a few objects such as a toy elephant, sausage, balloon, etc., are passed from player to player and later written down from memory. This can also be done with odours in tins or bottles (e.g., coffee, coal, oil, ginger, lavender, mint, cloves, vinegar, vanilla, etc.).

All Rovers are blindfolded except the game leader. He performs a series of half a dozen actions such as switching on lights, knocking over a chair, dealing cards, etc., and the fellows then endeavour to say exactly what happened. Another variation of this is to have one fellow in a room carry out various activities while the other members of the Crew listen at the door. They have to reconstruct the activity.

From behind a screen tap sharply on various metals. The metals must be identified.

Singing is another useful form of recreation and should be encouraged. There is a great deal of satisfaction, and *esprit de corps* is developed when a Crew has gained some proficiency in harmonizing and knows some worthwhile songs. In every community there is someone who is very proficient in teaching music, and if the Crew wishes to develop their group singing invite the expert to give some guidance.

**Suggested Meeting Agenda** | The following routine has been used with good result and may be adapted.

7.30: Opening ceremonies. The meeting should open promptly with the Mate in charge of the proceedings.

7.35: The Crew Treasurer collects fees, reports on the absence of any Crew member, and checks on reports of absence from previous meetings.

7.40: Reading of the Log of the previous meeting. Here the Scribe takes charge.

7.45: Crew Business. This is conducted under the chairmanship of the Rover Mate. First items to be considered are activities arising out of the reading of the Log. The Scribe will report on correspondence received and sent, and the Treasurer will give a financial report.

If the Crew has set up any committees to carry out Crew functions, the chairmen of those committees will give their reports. Sponsors will also report on the progress of their supervision of the Squires assigned to them.

As will be described later in this handbook, every Rover Scout should be pursuing a Quest of his own choice at all times. When once is completed another should be started, and during the business part of a regular Crew meeting the Mate should make certain that all members of the Crew are active in the pursuit of their own choice. The detailed requirements of Quests would be approved at this point in the business of the Crew.

Finally, new business may be introduced.

9.00: The Crew has been sitting for a considerable length of time and now is the opportunity for some form of recreation. The Rover Mate should make certain that every Rover has a turn sometime during the year to give leadership in the recreation part of the agenda.

9.15: Crew Quests. Here it is suggested that, in order to avoid aimless wandering, a three months', six months' or even a year's theme should be developed. For example, the Crew has adopted a three months' theme of "Preparing for Service". A St. John Ambulance Course could be considered a good form of

training. With this particular subject the Crew would have to arrange for special meetings to take the course, but during their regular weekly Crew meeting time should be allocated to review and practice.

9.45: Individual Quests. When a Rover Scout feels that he has completed his individual Quest he should be given an opportunity to present his findings to the Crew. This will not be on the agenda for every meeting, but when a fellow has carried his Quest through to completion the Rover Scout Leader and Mate should make certain that there is not unnecessary delay in having the Rover "show his stuff".

10.00: Recreation. This is the time in the programme where singing goes over very well.

Towards the end of the recreation period the Mate will turn the meeting over to the Rover Scout Leader who may give a five minute yarn. It is essential for the Skipper to carefully prepare his material, and if possible relate his talk to what the Crew is going to do or has done. This is the Rover Scout Leader's opportunity to use a few well-chosen remarks to help the Crew put straight anything that has gone amiss.

10.15: Closing ceremonies. Be sure to close on time. Many of the fellows in the Crew may have school the next day, and other will have to go to work.

Following the official closing, refreshments are served by the Crew Quartermaster, and a social half hour is enjoyed together. All take a hand in cleaning up the Den.

**Working from the Den** | It must not be assumed that every meeting should follow the pattern suggested. Certain evenings could be devoted entirely to special projects. A Crew may meet at their Den, go somewhere of interest and then reassemble at the Den for a sum-up, closing and coffee. For example, the Crew may have a Quest to learn all about civic services. This would entail visits to the police department, the fire department, the waterworks, sewage disposal plants, civic hospitals, and the endless variety of civic departments, which are organized quite differently from one community to another.

**Planning Meetings** | Each year the Crew elects its officers. The Crew must have faith in their ability to do the job delegated. Otherwise the whole idea of having officers is useless, and the set-up of the Crew will not be a good example of the democratic process. Of course, if the officers are not doing a good job, the Crew has a perfect right to take them to task, and then if necessary replace them at the next annual election.

Not the least amongst the responsibilities of the elected officers is the development of long range and detailed programmes of activities for the members of the Crew.

To develop long range objectives the members of the Crew Executive gather ideas from the members of the Crew, and at a Crew Executive meeting plot these suggestions. They aim at a balanced programme to include out-of-door activities, social and co-educational activities, service activities, and training and progress activities. If suggestions received from individual members of the Crew are not sufficient, or are unbalanced, the Crew officers put their fertile imaginations to work to develop a well-rounded outline for the year.

When completed, this whole plan is presented to a special meeting of the Rover Crew for consideration, adjustment, and final approval. This general plan is then circulated to all members of the Crew to be used as a ready reference.

To plan is one thing, but to put a plan into operation is another. Once again the responsibility falls to the officers of the Crew to see that the plan does operate.

The Crew Executive would meet to consider the delegation of responsibility in order that all members of the Crew take their fair share of participation. Every Crew should hold a quarterly business meeting, at which these detailed plans are outlined and responsibilities are allocated. The quarterly business meeting will probably be a lengthy meeting. However, this plan is to be preferred over the system of planning one week what will be done the next. The great fallacy of this is that every meeting becomes a business meeting, and when the Crew should be enjoying the fruits of their planning they have to stop and plan for next week.

The time schedule for the plan operates this way. The Crew Executive meets in June to set up the long range plan for the ensuing year. This plan is adopted by the Crew at the next Crew meeting. The Crew Executive develops the detailed plans for the first quarter, September 1st to November 30<sup>th</sup>, during the month of August, and the jobs are allocated at a subsequent meeting of the Crew. In early November the Crew Executive develops the detailed list of activities for the second quarter, December 1st to the end of February, and at a subsequent meeting of the Crew the responsibilities are allocated. The same pattern is followed for the development of the activities for the third and fourth quarter, and then the whole cycle starts over again.

**Service in the Den** | At meetings in the Den the Crew will find many opportunities to prepare themselves for efficient service, and to perform many good turns. Training for efficient service may take the form of instruction in First Aid, Civil Defence, fire fighting, care of pets and animals, auxiliary police service, traffic safety, and the learning in detail of the many, many things which go into making life a happy experience because one is prepared to help others.

Good Turns (which are the basis of Service) may be performed in the Den. For example, the Crew can operate a toy shop for the whole Scout Group, and supervise the work of the Cubs and the Scouts as well as doing much of the work themselves. A knot board can be made for the Troop, and the Rovers can whip the ends of the skipping and knotting ropes for the Pack. The variety of Good Turns is only limited by the imagination and willingness of the members of the Crew.

### *Quest No. 16 — Out-of-doors*

Because Rover Scouts are a Brotherhood of the Open Air it is natural that many of our meetings should be held in the out-of-doors. In fact, the wise Rover Scout Leader will lead his Crew into pursuing many activities in the out-of-doors which, on the surface would appear to be Den activities. For example, if the weather is favourable, a discussion on nearly any subject may be conducted in a quiet spot in a wooded glade just as well as in the Den. In this setting there are the added advantages of fresh air and change from being hemmed in by the four walls of a room.

**Principles** | In conducting meetings the same principles of participation, enjoyment, and knowledge gained apply as they do in indoor meetings.

Some interesting differences may appear in comparing the participation of Crew members in Den and out-of-doors settings. The quiet fellow may suddenly open up, and the dominating personality may recede into the background. Very often in different settings people react differently and the wise Rover Scout Leader will note these differences and lead his Rovers accordingly.

In the out-of-doors setting Rovers are presented with an endless variety of activities to pursue. There is everything in the wide, wide world to study, from the stars to micro-organisms in the soil. The problem is not “what to do”, but “what not to do”. Careful selection of activities is essential.

**Scouting for Boys** offers a host of suggestions and Quests to be pursued. These activities are conveniently grouped, and with a little imagination on the part of the Rover Scout Leader, the Rover Mate can be led to direct the Crew in an orderly manner through a series of interesting activities.

Enjoyment is much simpler to achieve in the out-of-doors than it is in the confines of a Den. Cook-outs, campfires and games, particularly observation games, as well as adventurous schemes and activities offer an endless variety of enjoyable experiences for young men. Camaraderie seems to overflow in the great out-of-doors.

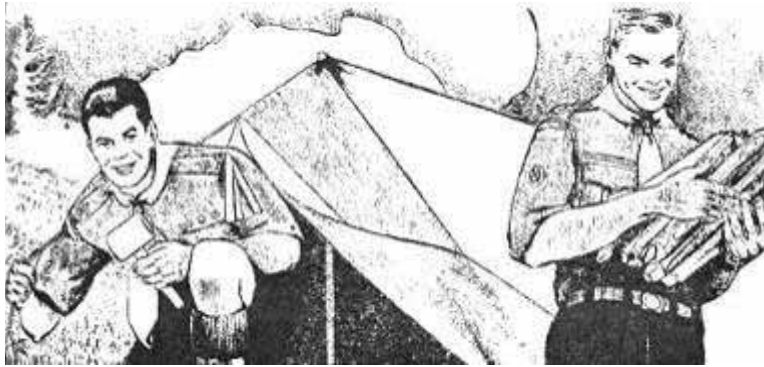

**Suggested Meeting Agenda** | Apart from having an opening to the meeting, a roll call and a closing ceremony, the out-of-doors meeting agenda should be kept as simple as possible. The meeting will run at a leisurely pace, and therefore it is usually possible to include only one major item in the programme. For example, if the Crew decides to engage in a conservation project, instruction and activity will use up nearly all the available time of an evening. Similarly, if the Crew decides to construct a pioneering project, they will have to really hustle to complete the project in an evening.

**Explorations** | Explorations are particular types of out-of-doors meetings. We use the term exploration in its broadest sense.

For example, get the Crew to explore the operations of a farm. This is valuable training for young men as it will give them an understanding of the viewpoint of a farmer concerning many things which ultimately have a tremendous effect upon the city dweller. A farm exploration is not simply a matter of wandering about some king farmer's property, but involves actually getting out and working with him — really learning how a farmer works and lives. In this situation the Crew will plow and harrow, milk the cows, pitch the hay, operate a combine or an elevator, feed the chickens, collect the eggs, according to the time of season or type of farm.

Of course, if this exploration becomes a week-end activity you will live on the property in tent, barn, or bunkhouse. You will rise with the farmer and his family, enjoy his hospitality and the things that entertain him.

One other illustration will serve to indicate the scope of explorations. How about spending a day with a commercial fisherman? Here you will mend nets, clean the boat, repair rigging, and participate in the handling of the catch.

Explorations of the primary industries of our country presents a real challenge to Rover Scouts to gain an understanding of some of the social and economic influences at work throughout the nation.

### *Quest No. 17— Co-educational and Social Activities*

It is basic that Rovers will primarily do their Rovering in the school of woodcraft. However, the objective of Rover Scouting is to make men; men who will feel at home wherever they go and in all sorts of company.

**Purpose** | Co-educational and social activities are included in Rover Scouting in order that young men may enjoy the company of the opposite sex, learn to feel at ease in their presence, and adapt themselves to the social graces which are the mark of a gentleman in our society. They are also included to help young men adjust themselves to work with girls and accept them on an equal basis in living as citizens in the nation.

**Social Activities** | Social activities have been placed ahead of co-educational activities, not because they are more important, but perhaps because they are more easily understood.

It is natural for young men eventually to enjoy the company of young women. However, there are some Rovers who are ill at ease in the company of girls, just in the same way that there are some who feel quite sophisticated. Some Rovers may have never dated a girl, while others may be “going steady”. It is quite possible that some members of the Crew may be married.

If the Crew is composed of members, some of whom are married, others “going steady” and still others who are unattached, the Rover Scout Leader has quite a problem on his hands. It is virtually impossible, under these circumstances, to arrange for an organized group of girls to meet with the Rovers for a social evening. On the other hand, the “not too interested” Rover might welcome (though he’ll never show it) the opportunity to meet a girl amongst a group. The only solution to this dilemma is to let the Rovers talk it out amongst themselves, and it is quite possible that some fellows will be able to arrange dates for others.

Of course, if the whole Crew is footloose and fancy free, they might all welcome the opportunity to meet with a Ranger Company or some other organized group of girls.



**Ideas for Socials** | When we speak of Crew socials, a Crew party immediately comes to mind. There are many occasions throughout the year when it would be quite appropriate to have a party. For example, there is St. Valentine's Day, and Hallowe'en. These are occasions when the Den can be decorated and a real atmosphere given to the affair. A Crew party needs careful planning if it is to be successful. More will be said about planning for social activities later in this Quest.

It is always a good plan to start off a party with some type of game which will mix people, and get them talking to one another.

There is an endless variety of good party stunts and games, far too long to be listed here. However, public libraries have many books on the subject and librarians will be only too please to suggest an appropriate book. *Games and Recreational Methods* by Smith is especially good, as is *Social Games for Recreation* by Mason and Mitchell.

Social occasions can take other forms than parties. There are hayrides, wiener and corn roasts, splash parties at the beach, picnics, banquets, and cook-outs. In fact, there is an endless variety of social activities that may be pursued. The main point to keep in mind is that the social aspects of Rover Scouting are important as long as they are kept in perspective. Socials should not predominate in the life of the Crew anymore than they should be excluded.

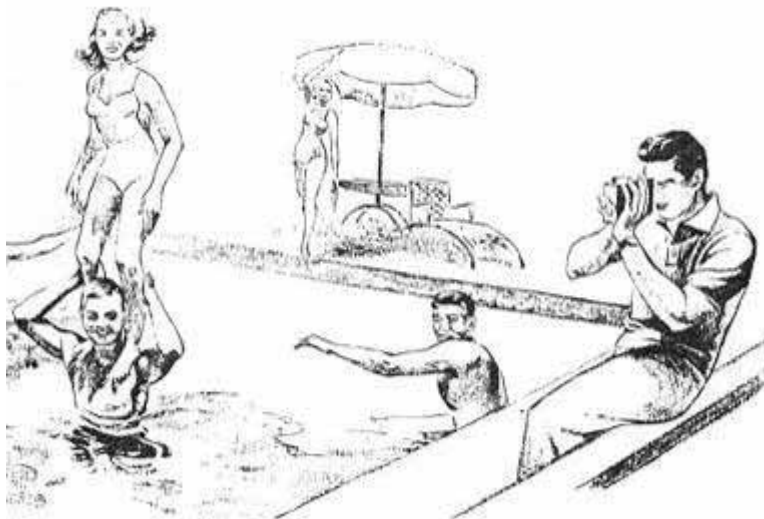

**Co-educational Training** | First of all, we must not overlook the fact that social activities in themselves present a very useful form of co-educational training. They provide a real opportunity for young people to learn how to get along socially in a group.

Co-educational training may take many varied and subtle forms. Take the subject of first aid for instance. Accidents do happen to men and women alike and yet because boys are generally trained to render first aid with another boy as a patient they are apt to get very flustered when they are faced with the problem of rendering first aid to a woman. Rover Scouts are of age where they should be able to face up to this type of training in a sensible manner.

Zest is added to discussions and debates if the female view is voiced. Therefore, by all means include girls in some programmes of this nature. This type of activity will have a very broadening effect upon the

outlook of the Rovers as well as their girls. Boy-girl problems brought into the open help young people understand each other. Does a girl expect a fellow going to high school to pay all expenses on a date? Does a fellow expect a girl to share expenses? These, and many more, are real problems to young people.

Some form of Good Turns, such as toy shops, require the assistance of girls, dressing dolls for instance. In fact, the feminine touch added to many Good Turns will make them all the more efficient.



**Planning** | As girls are to be included in co-educational and social activities, by all means use them on the planning and operating committee for the activity. However, it is well to keep in mind that this is a Rover Scout activity, and the Rovers themselves must take the lead and keep control of the situation.

**Decorum** | The best kind of discipline is self-discipline, and therefore as far as possible Rovers and their girls should be left on their own with a minimum of chaperoning. However, while we might be quite certain in our own minds that nothing is amiss concerning the behaviour of our young people when they do have a social or co-educational activity, there may be people who do not know too much about Rover Scouting who might start idle gossip. Therefore, it is imperative that proper appearances be maintained. There is too much at stake. Not only have we the reputation of The Boy Scouts Association to consider, but what is more important, we have to protect the integrity of the young people committed to our charge.

When young people are having a good time it is natural that enthusiasm will run high, and it is more than likely that this enthusiasm will be expressed by noisy behaviour. There are times and places when this is quite appropriate, but in public vehicles and public places this behaviour brings discredit to the Movement and to the individuals concerned. This situation needs careful handling. To stop it, once it has started, labels the Rover Scout Leader as a “wet blanket”. The secret is to prevent it from starting. When planning an activity it should become Crew tradition to give the Skipper an opportunity to say a few words towards the end of the evening. This is Skipper’s chance to end a meeting on a high note, and by force of his personality lead the young people to a point where they are willing to go home in an orderly fashion.

In some instances decorum may take the form of learning just plain good manners. Rovers should be expected to introduce their dates to the Rover Scout Leader. Skipper will have to be on his guard so as not to embarrass any of his Rovers because some fellows will have a different date for every function, and sometimes one Rover will turn up at a gathering with another Rover’s former “steady” girl friend.

If the Rover Scout Leader is married he should encourage his wife to participate in these social and co-educational activities. If she is a good sport she will enjoy these affairs, and the young folk will come to

respect her and welcome her presence just as much as Skipper's. If the Rover Scout Leader is unmarried it is a good idea to have a lady friend or sister at these gatherings. If this is not possible perhaps the Group Committee Chairman and his wife or the Mate's Mother and Dad would be willing to spend an enjoyable evening with the young people.

Meetings with girls are inevitable. If these activities are not conducted under the auspices of the Rover Crew they will be carried out in other organizations or totally unsupervised. How much better it is if they are carried out as part of Rover Scouting where the Scout Spirit helps ensure a high moral tone in this important phase of growing up to manhood.

## CHAPTER SEVEN

### *Rover Craft*

---

#### *Quest No. 18 — Crew Quests*



Crew Quests are the activities in which all members of the Crew engage. They are the common denominators which bind the Crew together, and they are based upon the principles of Scouting.

**The Quest of the Law and Promise** | While it is conceded that a young man must understand the meaning of the Scout Law and Promise from the viewpoint of a young man before he is ever invested, let us never make the mistake of considering that viewpoint to be perpetually static. To be a vital living force in the life of a person, the Scout Law and Promise must continually be re-interpreted to suit the changing conditions in this changing world of ours. What is right today may be wrong tomorrow. What is white today may be black tomorrow — or it may be some shade of grey. The concept of loyalty to one's parents may be completely upset when the man marries.

While it is very important that the Scout Law be interpreted for today's use, it is more important to know how those conclusions have been reached in order that the same orderly thinking may be applied at some future date to meet the changing need.

Questing, which is the game of exploring with a purpose, ceases to be a vague ethical idea, and



becomes a clear practical activity when it is based on the systematic study and practice of the Scout Law, each clause of which suggests different though closely linked possibilities for every Rover Scout, whatever his immediate outlook on life. To start a Crew Quest for the Scout Law it is necessary that each clause of the Law be considered in detail. The first step is to closely examine the obligations which that section of the Law imposes. The second step consists of preparatory work to find out the view of other people. The third step is to develop some form of practical application to test conclusions reached.

For example, in the first part of the Scout Law, "A Scout's honour is to be trusted," we are on the Quest of Truth.

How does this affect us in our daily lives? What should the Rover do when confronted with a situation in which he must act contrary to the spirit of the Scout Law in order to remain an acceptable member of the group? Should an untruth, a "white lie", be told for the sake of another person's feelings? The Rover sometimes hears about dishonourable methods being employed, which are actually condoned if they bring about other desired results. These are real problems which must be faced by the individual.

The second step is to find out how others interpret truth. There is the part which truth has played in the lives of historic persons. How truthful are the newspapers? What about diplomatic exchanges between nations? Are there any definite cases of dishonesty being made compulsory in various kinds of employment, and is there a remedy? Our concepts of truth change with the new discoveries in medicine and other sciences. How does the individual meet these problems?

The final step in this Quest is to develop practical activities bearing on the theoretical study of truth. For instance, find out how the Better Business Bureau operates, how to make use of its services, and how you may report what may be considered "shady deals". During the Christmas season, patrol a reforested area to prevent the stealing of Christmas trees.

With a little imagination it can be seen that each part of the Scout Law may be investigated, and interesting activities may be designed to bring them into play in the everyday life of the individual Rover.

**The Quest of Brotherhood** | The Quest of Brotherhood in a Rover Crew may seem to be quite unnecessary. However, Brotherhood is not as obvious as it may seem. Rovers, even Rovers in the same Crew, while professing to belong to the Brotherhood of Scouts, simply tolerate one another, and this cannot be called Brotherhood. We tend to label people and separate them into groups according to race, colour, creed, and economic or social status. This is also true about people generally who are "different" from us. We may profess Brotherhood, but be only tolerating them. We all have our prejudices — that is, we prejudge people. Depending on our own background, we all tend to have definite ideas about Jews, Negroes, Roman Catholics, Protestants, Americans, Frenchmen, and so on and so forth but, if we are honest with ourselves, we seldom, if ever, have any sound basis for whatever prejudices we may have.

The first step in this Quest is to determine what we mean by "Brotherhood". Are we willing to give the "shirt off our back" for our fellow man? Does it mean that we should treat our fellow Rover as if he were really our brother?

Now let us hear the viewpoint of others. Get the member of a faith not represented in the Crew to tell of his faith, and answer questions. Get a new Canadian to tell of his experiences as he makes his home in his new country. There are many minority groups and national clubs which would be very pleased to supply a speaker to express their point of view on the things that affect them.

To turn this Quest into a practical activity is extremely simple. Go out and meet people in their own bailiwicks; attend meetings of national clubs; take a group of young Negroes on a camping trip; arrange

to visit an Indian reservation; travel abroad getting away from the tourist haunts, to learn how people in other countries really live. We have discussed explorations in Chapter VI. This is an excellent opportunity to see how your fellow countrymen live, what they do, and how they think.

This troubled world certainly needs more people Questing for Brotherhood. Talking about it won't make it so. It has to be practised in order to be experienced.

**The Quest of the Out-of-doors** | The world of Nature around us has captured the imagination of man for centuries. There was a popular song which said, "The moon belongs to everyone, the best things in life are free." Yes, the simple enjoyment of understanding, or trying to understand the development of the flora and fauna of our country can form the basis of a major Quest. Many side issues, which can never be completed during a young man's stay in a Rover Crew, will become apparent to those who undertake this fascinating study. One of these may well become a most enjoyable lifelong hobby.

Hunting birds or animals with a camera, to "capture" them in their native habitats; bird-watching, with a good pair of binoculars, or simply rambling through the country, offer a wide scope of possibilities for exploring the natural things about us. Knowing the game and fishing laws; participating in conservation projects; understanding the balance of nature; renting or borrowing a microscope to study the unseen world about us, or securing the use of a telescope to study the heavens, presents a host of fascinating activities for Rovers to pursue in this Quest.

**The Quest of Service** | Service is an attitude of life. It is not a series of disjointed activities to help others. These are Good Turns. However, Good Turns do serve as the basis of training for Service.

Service is an attitude, and its outward manifestations are not necessarily the doing of Good Turns. If a Good Turn is undertaken with reservations, or begrudgingly, it does not reflect an attitude of Service. On the other hand, service may be in evidence on a person's job. He gets paid for doing his work, and therefore it is not a Good Turn, but if he tackles his job with his whole being, trying to do more than is expected of him, motivated with the desire to do the task well for the sake of the task, the Spirit of Service has been caught.

In the Quest for Service the first step is to learn the fundamental nature of the Spirit of Service. The concept of service can be caught and taught. It can be caught by the manner in which the Crew enters into activities, and by the example of the Rover Scout Leader. It can be taught through discussions, talks, and activities.

The Quest for Service may be divided along two lines. First of all there is preparation for efficient service. Secondly there is the rendering of service.

To prepare for efficient service, specific forms of training should be undertaken. For example, the Crew members may study first aid to the injured, water safety, civil defence, and other forms of "be prepared" services. To be able to render efficient service, young men must be able to lead others, and in some instances follow others. The Boy Scouts Association, the Y.M.C.A., various educational authorities, and community recreation clubs offer leadership training courses of a wide variety. Rovers should be encouraged to take advantage of what the community has to offer in this training.

Service is really the end result of Rover Scout training, and while we must expect Rovers to participate in Good Turns and develop an attitude of Service, it is when the Rover Scout reaches the Service Stage that we may expect the Quest of Service to really bear fruit. For that matter, the Quests of the out-of-doors, Brotherhood, the Law and Promise, and Service are continuing Quests. There is never really an

end to them, but we should expect Service Stage Rovers to be able to demonstrate and give real leadership along these lines to the community at large.

### *Quest No. 19 — Individual Quests*

Because of the variety of interests prevalent in any group of adults, it is self-evident that they acquired these different interests somehow and at some time. While individual interests develop throughout the whole period of our lives, there appears to be a particular time when individuality, and personal likes and dislikes in specific forms seem to burst forth and become more or less permanent attributes of the individual. The young boy is quite happy to eat, play, sleep, and seek affection. His desires are few and simple. The older boy seeks adventure a little farther from home, but here again his interests lie in a very limited sphere. On the other hand, the young man wants to seek everywhere to experiment and find out about many things which come to his attention on an ever-expanding horizon.

The Crew as a whole may include in its activities interests which everyone has in common, but the divergent interests must be the responsibility of the individual to pursue. It would be entirely unfair to tie all members of the Crew to an activity which is of vital interest to an individual only, or at the most, a minority.

**The Progress Badge** | After Investiture, a Rover Scout will continue his training by choosing a series of activities in which he is interested.

For our purpose we may conveniently group these activities under six major headings, and we should expect and encourage each Rover to pursue a subject under each of these headings in order to develop a well-rounded personality. To do otherwise would be to court disaster as, for example, the young man who is already efficient in a practical hobby or sport would naturally gravitate to that subject to become even more efficient, but at the expense of neglecting a cultural subject such as music. It is our task to help every young man to look wide.

The six major fields mentioned are training in world affairs, national affairs, cultural subjects, Scoutcraft and handicrafts, hobbies and sports. It will be obvious that under such general headings we can place nearly every subject under the sun. That is what is intended. Now comes the real problem. How do we establish a Quest?

The first point is to make it quite clear that no standard scheme of tests and examinations is possible. It is left to the individual Rover Scout undertaking a Quest to determine what the scope of his Quest will be. However, it will serve no useful purpose to let the matter stand as a vague generality. Each set of self-set requirements must be clearly defined and put down in writing. Another way of saying this is that each Quest must be defined in similar terms to those in which the Boy Scout Proficiency Badges are stated. For example, if a young man were to tackle a cultural subject and choose art as the specific subject, he might choose to narrow that down to the detailed subject of oil painting. Under this subject he might wish to explore the history of oil painting, the pigments used over the centuries, how colours are made, how to prepare a canvas, a comparison of Renaissance and Modern Schools, and how to paint. To pursue this Quest the Rover might visit art galleries, artists' supply houses, paint manufacturing plants, artists, an art studio, and even take art lessons.

Once the Rover Scout is fairly satisfied with his self-set requirements and has reduced them to writing, he submits them to the Crew Executive for approval. This serves two useful purposes. First of all, it will help ensure that the Rover Scout has not bitten off more than he can chew. Secondly, it will make certain

that no member of the Crew is trying to get by without putting his best effort into his Questing. There is one other point to be considered. Perhaps one of the Rovers or the Rover Scout Leader might have a friend who could give the Questing Rover counsel, advice, and even assistance.

The Rover Scout Leader's function in this part of the Rover's training is to keep an eye on his progress, to give him encouragement, and to see that Crew programmes and demands are not so encroaching on the individual's time that he cannot possibly go forward along his own trail. If, after frequent contacts, the Rover Scout Leader finds little progress, it may be well to review the self-set requirements to ascertain if they are too stiff for that particular individual.

It is important that when the Crew Executive gives the approval to the content of a Quest, a date of completion should be mutually agreed upon between the Crew Executive and the Questing Rover.

The Questing Rover should be required to keep a record of his activities on his Quest. If possible, samples, diagrams, and work done, etc., should be collected and catalogued. Thus it will be possible for the Crew Executive to periodically make a check on all Quests in progress to encourage the procrastinator, and those in difficulties.

When a Rover has completed a Quest to his own satisfaction, he will request sufficient time at a future meeting of the Crew to present his findings. At this meeting he will produce his models, samples, charts, and records, and give a talk, demonstration or use some other method suitable to his subject, to show that he has been active in the pursuit of his Quest and that he has fulfilled the requirements which he set for himself.

It is up to the Crew Executive to decide whether or not the Rover qualifies for a Progress Badge. While the Crew will set their own standards of competence, it must be borne in mind that the standard will have to vary according to the capabilities of the individual Rover, the opportunities available, and the subject matter chosen. The Rover, interested in art but living many many miles from sources of information, will probably expend more effort to gain a minimum of knowledge than the Rover who resides in a community where information concerning art may not be farther than a bus ride away.

The Rover Progress Badge is a leather lanyard, with a diamond knot at the end of the loop, made by the Rover himself, and it is worn around the left shoulder, under the shoulder-strap, with the end tucked in the left shirt pocket. For each subject satisfactorily completed, the Rover Scout is entitled to add an additional diamond knot to his lanyard.

It is reasonable to expect that by the time a young man is ready to leave the Crew, he should have accomplished a great deal along the lines of personal training, and he should have learned that the acquisition of knowledge is a continuing process which need never cease. This is one of life's most valuable lessons.

The Rover Scout Leader must realize that, if he is to help the young man to broaden his vision, to lead him to see what the world has to offer, and to help him to secure lasting interests, he cannot rely upon his own ability and interests alone. The help of other men and women is very necessary.

**Beyond the Crew** | To think that a Rover must pursue his individual Quests within the confines of the Crew is a great fallacy. For the younger Rover there is a Quest he cannot ignore; that is the Quest of academic education. He must complete his formal education. The older Rover must establish himself in his job. These are important Quests and, while we may not be able to take credit for the content of these Quests, the Rover Scout Leader certainly has an obligation to see that the individual Rover pursues these Quests with vigor and enthusiasm. Very often we can take credit for helping a young man to go a little

further than he himself has originally planned. It may even be necessary to convince a Rover to complete high school. Perhaps we can convince the young man, who is thinking of changing his job because of some temporary setback, that sticking with the job is the best thing. Of course, we must be sure of the facts.

Rovers will also find that many other voluntary organizations and clubs offer activities that are both instructive and interesting. We must recognize the fact that many young men will belong to many organizations and clubs, and it would be foolish to take the attitude that they are competing with us. They have an important part to play in the character development of a young man. Our job is to encourage the individual to participate and carry the Scout Spirit into all his undertakings.

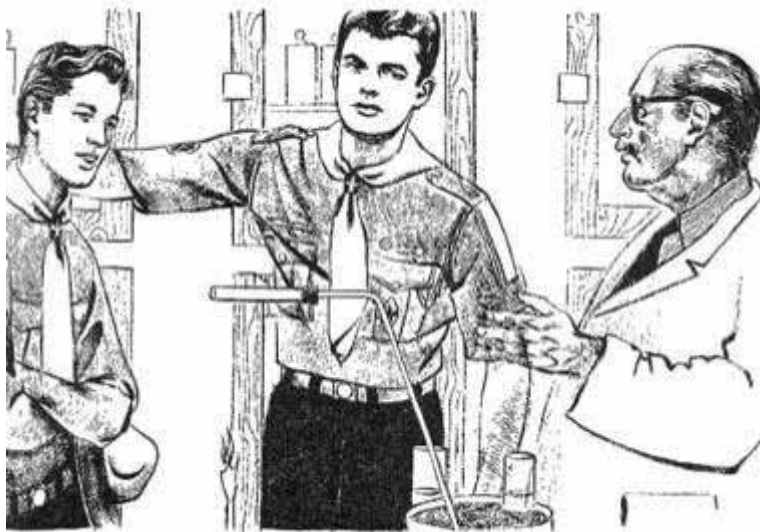

### *Quest No. 20 — Rambling and Logs*

Rambling — the art of walking with a purpose — is one of the key activities of Rover Scouting.

Rambling is not an art which is easily acquired. There is much preliminary spade work to be done; there are habits to be acquired first. The practice of observation, and the process of deduction are to be developed. However, while powers of observation and deduction may be developed through games and schemes, it is through rambling that these powers can be put to the practical test.

The purpose of having rambling as an activity is to help young men think for themselves; to reason out things and to discover the whys and wherefores of the daily happenings about them; helped to a certain extent by the advice and experience of others, but not dependent upon them. They must observe, comprehend, and analyze.

The art of observation and the ability to analyze form a most valuable part in the development of character, and rambling is an excellent vehicle to bring this about.

Through observation the efficiency of the senses may be developed — the eye becomes quicker, the hearing more acute. Through deduction the reasoning powers of the mind are developed, by imagination, research, common sense, and memory.

What will this training do for a person? It will develop resourcefulness, keen wits, wider vision and self-reliance — important factors towards success in a person's daily life — and the development of the ability to be of service to others. The practical value of such training in supplying a new quality in the character of a man is invaluable no matter what line of endeavour a person may select, whether it be the law or medicine, exploration or research, business or industry, or what you will. This training is essential too, to the individual, if he would gain a wider knowledge of the world, or if he would come to appreciate the character of feelings of other men; if he would enjoy the many little pleasures Nature can give him and, indeed, if he would make full use of the talents which God has given him.

The practice of observation and deduction, the development of memory in respect to small details and signs, and the ingenuity developed in their application, lead to a closer and more effective study of life as a whole, and of nature in particular. No one could fail to benefit physically, mentally, and spiritually from this activity, regardless of his abilities.

To ramble, the Rover must learn to be self-reliant. A knowledge of nature, the ability to observe with understanding all that is seen by the way, increases the interest of a ramble, for this will turn what otherwise might be a dull and tiring tramp, into a journey full of incident and pleasure.

From the foregoing it will be obvious that rambling should be a major activity of Rover Scouting.

**Training for Rambling** | All Rovers will want to be successful in their ramblings. This doesn't just happen — it will be the result of planning, of knowledge, and the application of the individual towards a goal.

As has already been intimated, the development of the powers of observation and deduction are a necessity for successful rambling. Observation should be stressed first, because it is through having the ability to observe that the success of rambling is assured. Deductive arts stem from observations.

There are many good Scouting books describing practices and games which teach observation habits. The art of tracking is most helpful to teach observation practices combined with deduction. This type of training must be continuous to be effective, and can take place at nearly every gathering of the Crew.

To ramble effectively it is necessary to develop an interest in the out-of-doors, and an urge to see new things, to adventure into strange places, and to know the wild lore of the field, stream, and wood. It is our aim to get Rovers to become so aware of their environment out-of-doors that they will learn to appreciate it. All that is needed to start this interest is someone who loves nature and can encourage the Rover's sense of wonder and excitement of discovery.

This should start when the young man first enters the Crew, by fostering his interest in appreciation for natural beauty, the ability to care for himself in the open, and an enlightened attitude towards the conservation of our natural resources. Towards this end, the Rover Scout Leader and the older Rovers, by their own enthusiasm and example, and by a judicious use of the natural interests of the Rover can arouse the initial interest in rambling.

To participate in rambling it is necessary for the Rover to be able to take care of himself out-of-doors. The planning of meals, the selection of equipment, the building of fires, and the care of the campsite all constitute good campcraft. There are many good books covering these subjects. Experiments along these lines can be done on short day rambles followed by discussions to evaluate. Ideas produced in this manner should be tested on subsequent rambles.

**Types of Rambles** | Once the preliminaries of preparations are behind the Rover there are two things to decide. First, when to go; second, where to go.

Most Rovers find that the only time they have for rambling is on week-ends and public holidays. Therefore, at the start rambles will probably take place fairly near home, but later there may be a desire to ramble through entirely new country at some distance from home. Perhaps it may be possible to drive a hundred miles on Friday evening to an overnight camping spot to be all ready Saturday morning for an adventurous expedition for the week-end.

Whatever the destination, it is a good thing to plan the route roughly beforehand, but don't let the plan be hard and fast arrangement. One of the great joys of rambling is the wonderful sense of freedom it gives the Rambler.

A Rover rambles for the sheer joy of walking and observing the world about him. However, for the keen naturalist, nature study may be combined with the ramble. For the historian, historical rambles add enjoyment. Rambling can even be combined with Crew or individual Quests. Freedom of choice is keynote.

This country's national and provincial parks provide ideal facilities for rambling through almost virgin country with unlimited space within which to roam. Historical sites should also be considered, but here very little distance will be covered in relation to the amount to be observed and noted.

**Equipment** | As part of the equipment for rambling, a map, is necessary unless the country is well known, and even then a map will frequently add much to the interest of the journey. It is worthwhile to get a good map; an Ordnance Survey map, scale 1 mile : 1 inch, is ideal for the purpose. To understand these maps it will be necessary to learn the meaning of conventional signs, scales, contours, and the practice of seeing solids from the flat surface of a topographical map. Plenty of outdoor experience in all seasons will turn this skill into a habit.

A good compass is also an essential piece of equipment, and Rovers must learn to trust their compass, especially when rambling through unknown territory, rather than relying on intuition.

Pack sacks and camp gear will be discussed in another chapter, but suffice it to say here that the skilled camper, one who knows how to make himself comfortable with a minimum of weighty articles on his back, will become the skilled Rambler.

A regular part of equipment for the ramble will be a notebook and pencil. The notes and sketches which the Rambler will enter into his notebook will form a valuable record of his observations and deduction.

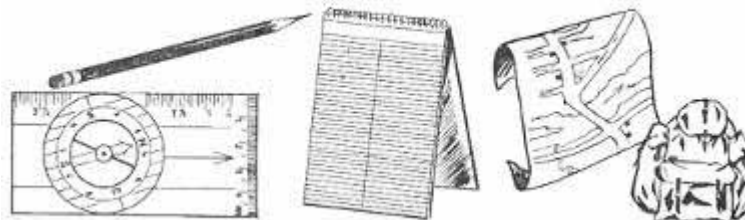

**Logs** | The keeping of a log book will never be popular with young men if it becomes a matter of recording where they went and what they did. This can be a very dreary practice. However, if we compare the rambler's log with the scientist's notebook, the surveyor's fieldbook, or the doctor's case history it is possible to see the value of logs and the reason why the rambler should keep a log. Ramblers maintain logs in order to record their findings, observations, and conclusions in a methodical manner. Logs illustrate the results of rambling.

Logs are not the most important part of rambling, but they are a necessary part of this activity. When recording details of a ramble the questions — what? — where? — when? — how? — why? should all be answered and recorded. Unrecorded details are soon forgotten and knowledge that should be gained from the experience never really becomes a part of the rambler.

By developing the habit of recording, powers of observation are stimulated, and the observer learns to look for significant details.

It must be borne in mind that training in reporting is very valuable as many vocations and activities in life require a person to present comprehensive reports.

How should logs be kept? That is a very difficult question to answer. There is no standard or recommended method, nor is it desirable that there should be. Each log should represent the personality of the log keeper, and allow him full scope for creative thinking and activity.

The script in some logs may be only cryptic notes. In others it may be a flowing narrative. Even poetry may be a person's method of presentation. Some take quite literally the fact that "a picture is worth a thousand words" and the content may be nothing more than a series of sketches, postcards or photographs linked together with captions. Others may prefer to combine any, or all, of the aforementioned methods. Whatever method is chosen, as long as it can stand the test of a good log it should be considered quite satisfactory. The test of a good log answers "yes" to the question "does it give the information required?"

From the beginning, it is advisable to use a common size paper. This makes it easier for filing or binding. A small loose-leaf notebook, preferably with blank paper, is suitable.

Logs should contain certain standard information such as, who is reporting, to whom, date, time, weather conditions (direction of wind, temperature, precipitation, cloud formations), compass directions, object of the ramble, and who accompanied the reporter.

An organized form with ruled columns headed to receive appropriate information may be of assistance in making the notes. This would ensure that all the important factors are recorded each time.

A log should be of potential value to others, and therefore it would be necessary to include sketch maps of the route followed. It is a common error to omit approximate scale and north point on these sketch maps. They are quite useless without this essential information.

It is a contentious point whether or not to write a finished log on the ramble. Some maintain that the permanent record should be made while the activity is in progress. Others feel that a more workmanlike finished job is necessary. The danger of the first view is that sloppy work breeds more sloppy work. The danger of the latter view is that a high and rigid standard of artistic ability is measured instead of the accomplishments of the ramble.



There is a happy medium between these two points of view. Take good notes while the ramble is in progress, and touch up at home.

There is available, from the Association, and excellent little booklet, **The Rover Rambler Badge Book**.

**The Rambler Badge** | The object of this badge is to encourage the Rover to hike and ramble for sheer pleasure. It is not an athletic feat, and the actual badge may be gained over quite a long period of time.

The Rambler Badge is not reserved for the individual who is a really keen hiker. It is for every Rover who remembers that “a journey of a hundred miles is started with a single step.”



### *Quest No. 21 — Camping and Camp Gear*

**Rover Camping** | Scouting is a camping movement, and we believe that many of the fine attributes of good citizenship are learned in the school of woodcraft. Therefore, the Crew should have many opportunities to participate in short and long term camps, and make adventurous camping tours to distant and strange places.

In practice it has been found that many Crews do not go on an annual camp. Employment, and part-time employment commitments very often prevent this. However, where possible, Crews should plan an annual camp or tour even if it is of only four or five days' duration. In any event, it is usually possible to arrange for many week-end camps.

The Rover camp differs considerably from the Boy Scout Troop camp. For one thing, to the young boy it is fun to go to camp just to camp. For the young man, camping is incidental to the major activity. In other words, Rovers don't just go to camp, they go on a fishing or exploration trip. They camp while they are en route and at their destination.

The moving camp, especially a canoe trip, appeals to Rover Scouts. Some Crews have conducted moving camps on horseback and on bicycles, while others prefer hiking.

Activities while in camp are not usually formalized. This does not mean to say that they should not be planned. Morning flagbreak, evening flag lowering and lights out at night, which lend atmosphere to the camp and set a tone of discipline and good order, should be regarded as “musts”.

Inspection should not be necessary in a Rover camp. However, the Mate and the Rover Scout Leader are responsible for the health and welfare of the Rovers and, therefore, if standards are slipping, which will be revealed by “informal inspections”, the offenders should quietly be brought into line. If camping standards are sloppy the Rover Scout Leader should insist upon formal inspections until standards have been raised. Just because we go to camp, there is no reason why we have to “go native”. Comfortable and sensible dress, together with personal cleanliness and good grooming, are the keynotes.

Finally, leave the site of every camp you use scrupulously clean. Remember — leave nothing but your thanks.

**Places to Go** | One adventurous camp or tour per year should be among the list of activities for every Crew. By pooling resources, trips to distant places are well within the realm of possibility. Tours may be taken by bicycle, private or rented car, airplane, boat, train or bus. Travelling by bicycles and car allows great freedom of movement and permits stopovers at Scout and public campsites with a consequent reduction in travel costs.

By all means, travel in uniform. It is a pass to many places that would be denied to the group in other attire.

A motor tour can be a marvellous experience. Planning it with maps, tourist folders, history and geography books for references, working out what to see, where to stop, where to camp, and what to eat, are the preliminaries which lead up to the main event.

We must avoid the mistake of considering a tour to be an endurance contest. Make certain that the destination is within striking distance, and when you arrive you should have a few days to relax and see whatever you planned to see, and do whatever you planned to do.

Your objective might be any one or more of the national and provincial parks, and you will want to follow the trails, climb the mountains, swim, or take advantage of whatever that particular park has to offer.

On the other hand, your objective might be a great city like New York, camping en route. If the members of the Crew have never been to a legitimate theatre, by all means take in a show. Perhaps some of the Crew have never seen a zoo. How about a trip to a planetarium? Don't forget to partake of food that is unusual. There is adventure to be found even in a great city, and a trip to a great metropolis can be an out-of-doors experience to be remembered for a long time.

The most readily accessible “foreign” country to Canada is not East or West but due South — to Mexico. Mexico can be reached inexpensively and comfortably by bus or car, and the route you take will include stopovers at interesting places.

As in all trips, you will enjoy the planning. For those sceptical as to its value, here are some of the steps you can take, and you will see what a lot of material there is for Individual and Crew Questing. Study the language — Spanish, or course. Use phonograph records, particularly for the pronunciation, and concentrate on the everyday phrases which are useful to the traveller. Use the Crew meetings to practise with each other, ordering meals, asking directions, etc.

Getting your passport — why do we have such things, what use are they? Why must we be vaccinated and have inoculations? All these questions and many more besides, can be answered by the Department of Citizenship and Immigration, so find out. While you're at it, check with the Customs Department.

Getting your tickets — routes and connections are planned. Find out how. Find out also how the Mexican Bus Company gets part of the money paid in Canada.

Getting your accommodation — ever been behind the scenes in a hotel? Try it and then maybe you will understand the differences between the American Plan and the European, and why hotels differ in their prices. American State and National parks are well equipped for camping. Find out about them.

Getting to know the food — there is more to American cooking than the “Red Hot” and more to Mexican than “Chili Con Carne”. Dig out some of the recipes and amaze your girl friends at the next social.

Planning your route — lots of time, lots of fun. Plan your stopovers, and plan your time there, making sure that you see as many of the local attractions as possible. If you plan well in advance you can get into all sorts of places merely by writing.

Getting to know Mexico — how are you on Hidalgo, Benito Juarez, Maximilian, Cuauhtemoc or Zaragoza? What are The Pyramid of the Sun and Popocatepetl? The Mexican Government Tourist Bureau will be able to supply some of the answers, but better still, get in touch with a Mexican or someone who has been to Mexico.

**Camp Gear and Kit** | Many young Rovers, particularly those who were First Class Scouts, will have an elementary knowledge of camp gear. As they progress through Rovering it is expected that they will develop their knowledge of camp gear to the point where they will have keen appreciation of the values of all types. In addition they will gradually accumulate their own personal gear and kit through experimentation and what they do not purchase they will manufacture.

The following is a list of the usual items to be found in the lightweight camper's pack.

**Camping Gear**

Tent  
 Poles  
 Pegs  
 Ground sheet  
 Stove  
 Ground blanket  
 Gas container  
 Windscreen  
 Cook kit  
 Water bucket  
 Wash basin  
 Trowel  
 Dish cloth  
 Steel wool  
 Tea Towel

**For Mountain Trips**

Anorak  
 Toggle rope  
 "Alpinstock"

**Personal Kit Packed**

Rucksac  
 Down sleeping bag  
 Sheet sleeping bag  
 Night attire  
 Mug, plates, K.F.S.  
 Towel  
 Toilet articles  
 Spare Scout shirt  
 Spare Scout shorts  
 Stockings (2 pairs)  
 Socks (3 pairs)  
 Underwear  
 Handkerchiefs  
 Spare scarf  
 Boots  
 Running shoes  
 Sweater, heavy  
 Bathing shorts  
 Boot cleaning materials  
 Needles and cotton, etc.  
 Raincoat  
 Toilet paper  
 Flashlight  
 Log book  
 Pencil  
 Paper and envelopes  
 First aid kit  
 Haversack

**Personal Kit Worn**

Hat  
 Woggle  
 Neckerchief  
 Scout shirt  
 Scout shorts  
 Scout belt  
 Scout stockings  
 Garter tabs  
 Shoes  
 Compass  
 Map  
 Knife  
 Whistle  
 Matches

NOTE: The camping gear can be shared if there are several in the party.

**Anorak** | (See Figs. 1, 2, 3) The Anorak is an outdoor garment fitted with a hood and draw cords and is intended as a protection against wind. It should be treated with a water repellent, but the pores of the cloth should not be closed up with a waterproofing mixture as this causes internal condensation and dampness.

It should be very loose-fitting so as to give room for movement and so that sweaters as required can be worn underneath.

**The Anorak** | Materials required:

- 3½ yds. good quality drill, 32 in. wide
- 3 yds. nylon cord
- 6 buttons
- 2 large sheets brown paper

Rule the brown paper into 2 in. squares and copy the design from the pattern sheet. Cut out the patterns and pin them on the cloth, which should be folded lengthwise as illustrated. Now cut out the pieces. Allowance has been made for turns, so cut close to the pattern.

Join the backs of the hood pieces (A) with a French seam. Join the two cord pieces (E) together at end "B" and then sew them on the hood, turning in the raw edges. Join the throat piece (M) to the hood and hem round the bottom of the face opening. Make up pockets (C and D) and flaps (K and L) and sew on front. Make up sleeve tabs (G and H) and catch them into the seam when making up the sleeves. Fix the sleeves into the body starting from the underarm. Fix the hood in place, turning in the raw edges. Hem the bottom edge leaving a slit for the draw cord. Hem bottom of sleeves. Thread draw cords into place, make button holes and sew on buttons. Paint the garment with NEV solution.



Fig. 2

The Anorak—Pattern Sheet

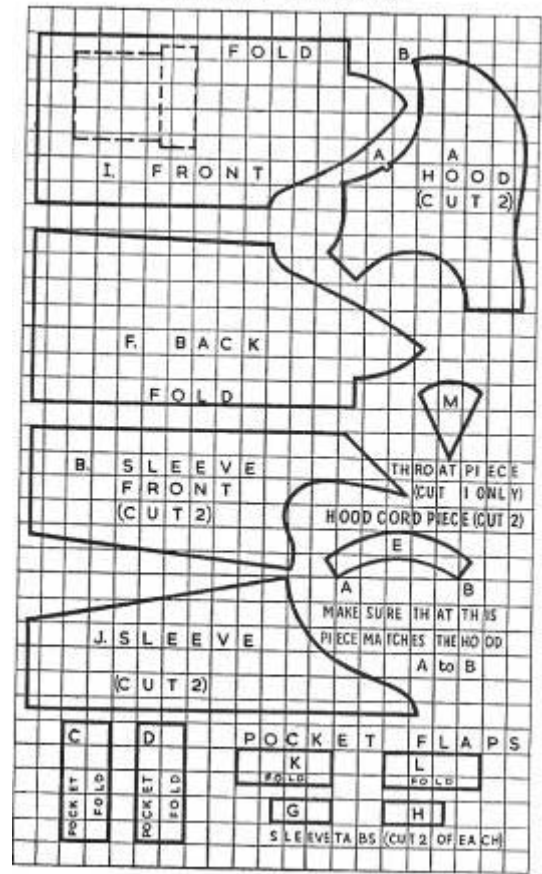

Fig. 3

**Bags** | Cloth bags of various sizes can be made from suitable oddments of material for use as protection for dirty things such as boots, cook kit, etc., for storage of dry foodstuffs or for convenient packing of pegs, poles, etc.

**Basin, Canvas** | The folding basin of waterproofed canvas can be obtained in various shapes. Use it for personal hygiene and not for washing up greasy plates and pans.

**Bucket, Canvas** | The folding bucket of waterproofed canvas can be obtained in various shapes. The wedge shape is favoured.

Experiment with plastic materials and a metal screw top and you will find you can make a satisfactory water container.

The choice of the clothing to be worn and to be carried as spares depends on the time of year, where you are camping and your own personal needs. If you can keep warm, dry, and clean under all conditions and still not carry too much weight you will either be very efficient or very lucky, but have a go just the same and try to profit by your mistakes.

**Fires** | There is little need to take part in the old argument “fires vs. primus”. You should be able to use one or the other equally well according to the facilities and time available. A reserve supply of waterproof matches can be made by pouring melted candle wax into a full box of “strike anywhere” matches. You can dig out one with a knife as required. Take care that your fire does not travel underground along old dry roots, etc. This could start a serious fire after you have left. Let your fire be like your kit, small and efficient.

**First Aid Kit** | All Rovers should carry a first aid kit and be able to deal with the minor injuries sustained outdoors.

**Fly Sheet** | A fly sheet stops spraying during heavy rain and also provides additional shade in hot weather. There should be about 6 in. clearance between the fly sheet and the tent. A fly sheet is desirable in bad weather if there is much danger of frequent contact with the inside of the tent. In reasonable weather and with a good tent of suitable dimensions it is not essential.

The design and making of fly sheets follows the general lines of tent designing and tent making.

**Food Storage** | Dry foods such as sugar, oatmeal, bread, tea, etc., are best stored in bags made for the purpose. The sugar bags should be of waterproof or plastic material, but the others may be of any light cotton material. Screw-top aluminum containers should be used for jam and those with a plastic or glass lining will do well for butter. Shaped aluminum containers can be obtained for holding eggs.

A haversack which packs on top of the rucksack is advised for the transport of food. It can be used as a food store in camp and can, of course, be hung up in a tree for safety and coolness. A small sack, about 15 in. by 12 in. makes a convenient shopping bag and is useful for storing vegetables. A string bag is also quite suitable for this purpose and is very light.

**Footwear** | Shoes should be stout, reasonably waterproof and large enough to provide good fit over thick stockings. Some form of light hobnails will prevent slipping on greasy or icy tracks. The patterns of nailing are many, and any Crew interested in mountain climbing should look for this information in a suitable reference book on the sport.

Boots are the best footwear for all hiking activities. They should be strong and reasonably waterproof with a sewn-in tongue and a stout whole sole. They should fit snugly, particularly around the ankles, when wearing thick stockings as well as socks. It is undoubtedly best to go to one of the specialist boot makers, but their boots are expensive and those whose feet are still growing may have to consider a less expensive substitute, such as a pair of well-fitting army-type boots.

A lighter form of footwear such as running shoes or moccasins should be used as a change in camp.

**Ground Blankets** (See Fig. 4) | This is a blanket made of light-weight woollen cloth and is used with a fitted ground sheet to cover the whole of the tent floor. The ground sheet and blanket have rings in similar positions so that they can be pegged down inside the tent, the same pegs being used for the sheet and the blanket. The material is joined up to size and, after fixing patches of double cloth where the rings will come, the outer hem is made and then strengthened by sewing on a linen tape all around. Rings are fitted as required. A brightly coloured cloth, red or tartan for example, gives an appearance of warmth to the tent interior. The ground blanket gives considerable protection against the cold which rises from the ground and it also prevents the condensation of moisture on the top surface of the ground sheet.

**Ground Blankets** | The ground blankets for the tents described in Fig. 4 are made as follows:

The "A" or "Bivvy" and the "Alaskan"

- Materials required: 2¼ yds. light woollen cloth, 54 in. wide  
 8 yds. linen tape, ⅝ in. wide  
 4 "D" rings  
 4 ft. cotton tape for side ties, ½ in. wide

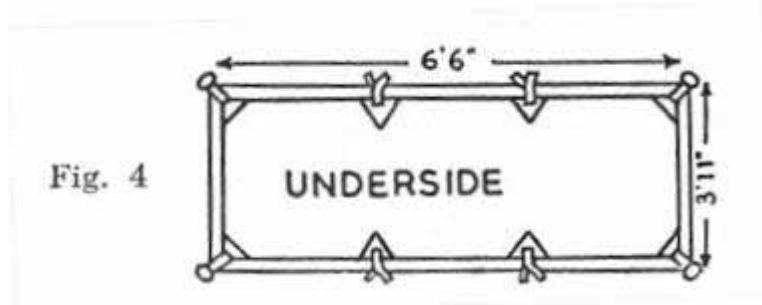

Fig. 4

Trim one side of the cloth so as to leave the main piece 48½ in. wide. Cut patches of double cloth from the remaining strip and sew in place. Hem the blanket and tape all round. Fix rings on tapes and tie tapes, as required.

The "Senior" (Itisa Type)

- Materials required: 3¾ yds. light woollen cloth, 54 in. wide  
 11 yds. linen tape, ⅝ in. wide  
 11 "D" rings

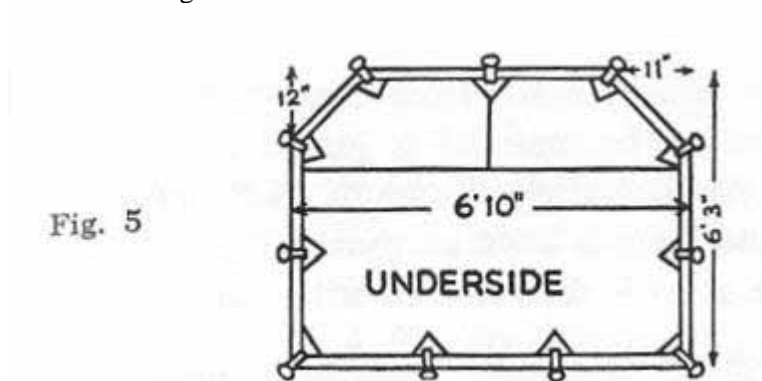

Fig. 5

Cut one piece 7 ft. by 54 in. and two pieces 2 ft. by 54 in. Join the two small pieces to make a strip which is then joined to the large piece. The corners are trimmed off and the blanket finished off as above. The patches can be cut from the odd pieces of material.

The "Cairngorm"

- Materials required: 2½ yds. light woollen cloth, 54 in. wide  
 8 yds. linen tape, ⅝ in. wide  
 6 "D" rings  
 4 ft. cotton tape for side ties, ½ in. wide

Cut the cloth as follows: Join the small triangles to the wide part of the large piece and finish off as above.

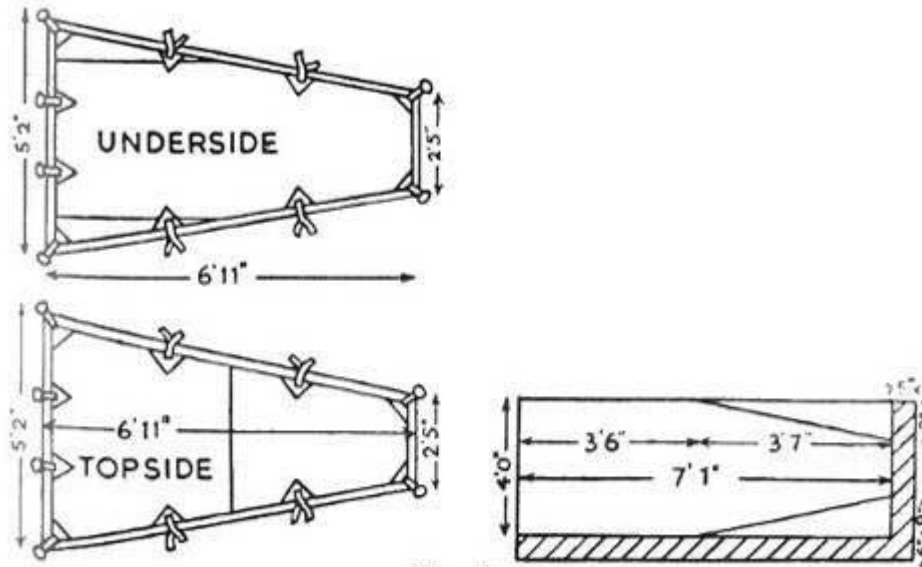

Fig. 6

**Ground Sheet** | The ground sheet is a very important part of the camper's gear and it must be absolutely waterproof. One test is to hold it up against a strong light. If any pinpoints of light can be seen, the sheet is not waterproof.

Ground sheets can be made from close-woven cloth such as Egyptian cotton. The material is joined up to size, and, after sewing on patches of double cloth where the rings will come, a stout outer hem is sewn all round. Rings are fitted as required and the sheet is treated with waterproofing.

These very light ground sheets need to be used with care, as sharp stones or roots can puncture them. Given fair treatment they will last for many years.

It would also be well to consider a poncho type ground sheet which can double as a raincoat. These can be made or purchased from the Association.

**Ground Sheets** | To make lightweight ground sheets for the tents described, proceed as follows:

The "A" or "Bivvy" and the "Alaskan"

Materials required: 3 yds. Egyptian cotton, 42 in. wide  
2 ft. linen tape, 5/8 in. wide  
4 "D" rings

Cut two pieces of cloth 4 ft. 2 in. by 42 in. and join them along the selvages. Prepare patches from the odd piece. Finish off as described for the Ground Blanket. Proof with the oil mixture described under "Waterproofing" (page 90).

The "Senior" (Itisa Type)

Materials required: 4½ yds. Egyptian cotton, 42 in. wide  
2 yds. linen tape, 5/8 in. wide  
11 "D" rings



Cut two pieces of cloth 6 ft. 6 in. by 42 in. and join them along the selvages. Prepare patches from the odd piece.

Finish off as described for the Ground Blanket and proof with oil mixture.

The "Cairngorm"

Materials required: 3 yds. Egyptian cotton, 42 in. wide  
 1 yd. linen tape,  $\frac{5}{8}$  in. wide  
 6 "D" rings  
 4 ft. cotton tape for side ties,  $\frac{1}{2}$  in. wide

Cut out the cloth as follows. Join the two pieces together. Prepare patches from the odd piece. Finish off as described for the Ground Blanket and proof with oil mixture. There is no need to tape any of the ground sheet hems.

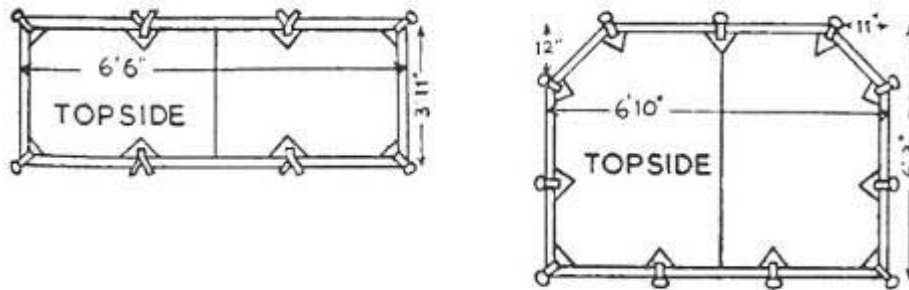

Fig. 7

**Sleeping Bag** (see Fig. 8) | Down-filled sleeping bags retain heat well and so give considerable warmth for small bulk and weight. Best quality down such as goose down is very light and fluffy and allows plenty of air to be retained in the cell-like spaces which it forms. Cheaper downs and kapok do not retain as much air and consequently a greater quantity of filling must be used. This means more bulk and weight. When buying a bag, see that it springs undone when the tie tapes are released. It is less expensive to buy a wedge-shaped quilt and to make this into a bag by sewing up the bottom and side and fitting a zipper and draw cords, than it is to buy a made-up bag. A complete sleeping bag can also be made at home, and the saving is considerable.

**Sleeping Bag**

Materials required: 6½ yds. Egyptian cotton, 42 in. wide  
 1 lb. 2 oz. best goose down  
 1 zip fastener about 30 in. long  
 2 yds. soft cord for top draw cord  
 cotton for sewing  
 24 paper bags, about ½ lb. Size.

The bag is first made up as a quilt and is sewn up afterwards.

The cloth is cut as follows:

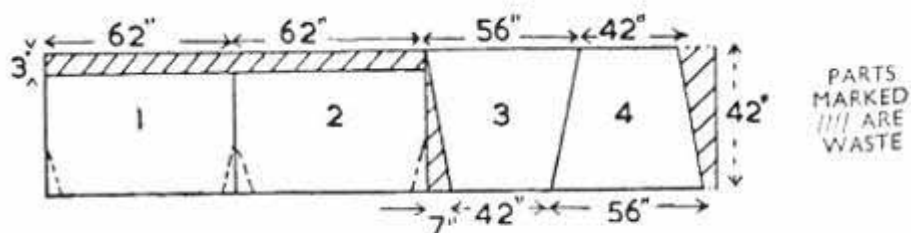

Fig. 8

Sew together pieces 1 and 3 along the selvages with a run and fell seam. Trim off the corners of piece 1 to get a straight tapering edge. Do the same with pieces 2 and 4. Make sure that the two wedge-shaped pieces are identical, and taking each separately, turn in  $\frac{1}{2}$  in. on the sides and narrow end and  $1\frac{1}{2}$  in. on wide end. Take one of the wedge-shaped pieces and on the plain side mark out the "squares" in tailor's chalk. Pin the two pieces together and sew along all the vertical lines from A-a to K-k and also from P-p.

When working with goose down, choose a place that is free from drafts and work on a large tray made from a sheet of brown paper with the edges turned up and pinned. Take half the down and divide it up into the twenty-four bags. The best method is to weigh it out on a small pair of letter scales using lead shot as weights. Make a cup from a milk bottle top and balance this against one of the paper bags, using some of the shot for this purpose. Find out how many pieces of the shot go to half an ounce. Suppose, for example, you find it is 140, then the weighings will be as follows:

Bags 1 to 18 use 120 pieces.

Bag 19 uses 108 pieces.

Bag 20 uses 90 pieces.

Bag 21 uses 72 pieces.

Bag 22 uses 48 pieces.

Bag 23 uses 30 pieces.

Bag 24 uses 12 pieces.

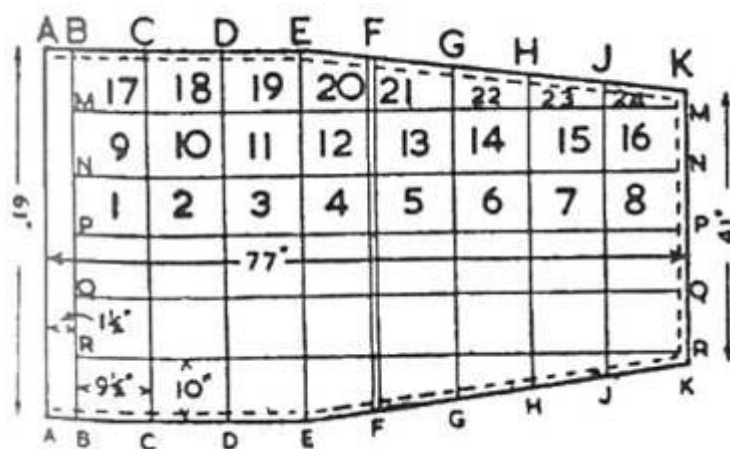

If you find a different number of shot to the half-ounce, the other quantities can be adjusted proportionately.

To fill the sleeping bag, you will require a supply of pins and an assistant to hold the work while you do the filling.

Take paper bag 1 and get all the down from it squeezed tightly in your fist. Thrust your hand down the first "pipe" in the cloth and release the down in square 1. Put two or three pins on the line N-n to hold the down in place. Continue the same way with squares 2 to 8. Take the work to your sewing machine and run a single line of sewing along N-n, at the same time removing the pins. Repeat for squares 9 to 16, sewing along M-m, and for squares 17 to 24, sewing from B-m.

Care will be required in getting the down into squares 17 to 24 and more pins than usual may be needed.

Now take the remaining half of the down and repeat the process for the other side of the bag.

Complete the bag by joining E-m to e-r and m-p to r-p with several lines of sewing. Turn the bag inside out (it will then be the right way round for use) and sew the zipper fastener to B-e and b-e with the zipper lever inside. Attach a tassel or a bit of cord to the zipper lever so as to find it easily in the dark. Thread the draw cord through the tube in the cloth between.

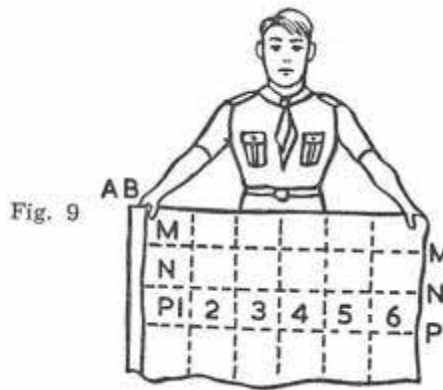

**Rucsac** (see Fig. 10) | The rucsac is a very important item of the hiker's kit. The framed type is very desirable for long-distance hiking with a camping load.

The soft or frameless rucsac is most useful for lightweight hikes and canoe trips, and can be made at home to suit particular requirements.

**Rucsacs, Soft** | A soft rucsac of the kind shown can be made quite easily, but care must be taken is a sewing machine is used. Where several layers of thick canvas have to be sewn, it is better to stitch by hand.

- Materials required:
- 4 ft. 9 oz. cotton duck, 32 in. wide
  - 1 yd. khaki webbing, 2 in. wide
  - 2 straps for pickets, 7 in. long
  - 3 straps for flap and shoulder straps, 15 in. long
  - 1 large "D" ring
  - 12 eyelets No. 23
  - 4 ft. draw cord
  - 2 pieces stout pliable leather, 3 in. by 2 in.

Cut as follows:

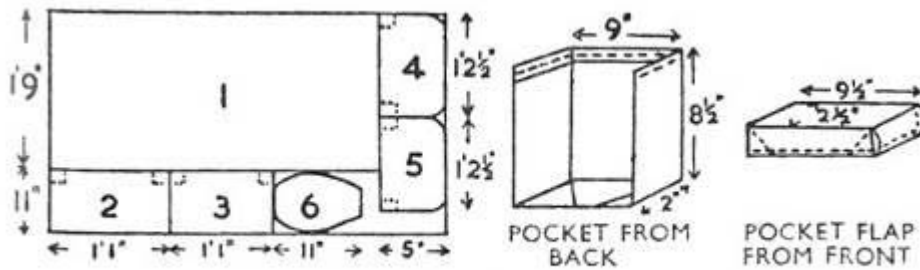

Fig. 10

First make up the pockets. Take pieces 2 and 3 and hem along the selvedge. Make the box corners folding in 2 in. squares and sewing them in place. Make the pocket flaps from pieces 4 and 5, turning in 2½ in. squares at the corners. Then hem round the curves and front edge. Take piece 1 and make a 1 in. hem at each end. Sew the pockets and flaps in place, turning in the rough edges. Cut the flap to shape and hem all round. If desired, a pocket made from an odd piece of drill can be sewn to the underside of the flap. Now sew the flap to the back of the bag. Take one of the pieces of stout leather and shape it to fit the “D” ring. The other piece goes inside the bag, about 2 in. down from the top edge. The leather patches are then stitched firmly together. Take one of the 15 in. straps, cut off the buckle and 2 in. of leather and sew this to the bag just above the pockets. Sew the remaining piece to the bottom edge of the top flap. Fix the short straps to the pockets in a similar way. The remaining 15 in. straps should be cut about 2 in. from the buckles and again about 2 in. farther on. The buckles are sewn to the bottom corners of the bag. The short pieces of strap are used to fix the webbing straps to the “D” ring and the remaining pieces are sewn to the other end of the webbing. Small patches of leather may be put on the underside when sewing on buckles and straps. This gives extra strength. The top hem of the bag is now pierced and the eyelets put in. If an eyelet goes right through the bag and top flap in the middle of the back it will be found that the draw cord can be anchored to the “D” ring. Give the bag a coat of waterproofing to finish it off.

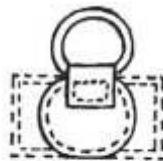

Fig. 11

**Rucsac, Framed** | A framed rucsac which is very much lighter than the “commando” type can be made if you can obtain a frame.

Materials required:      One 17 in. tubular frame  
                                     2½ yds. 9 oz. cotton duck, 32 in. wide  
                                     1 piece drill 24 in. by 25½ in.  
                                     15 yds. cotton webbing, 1 in. wide  
                                     Various straps, buckles, etc.  
                                     4 ft. draw cord

The cloth is cut as follows:

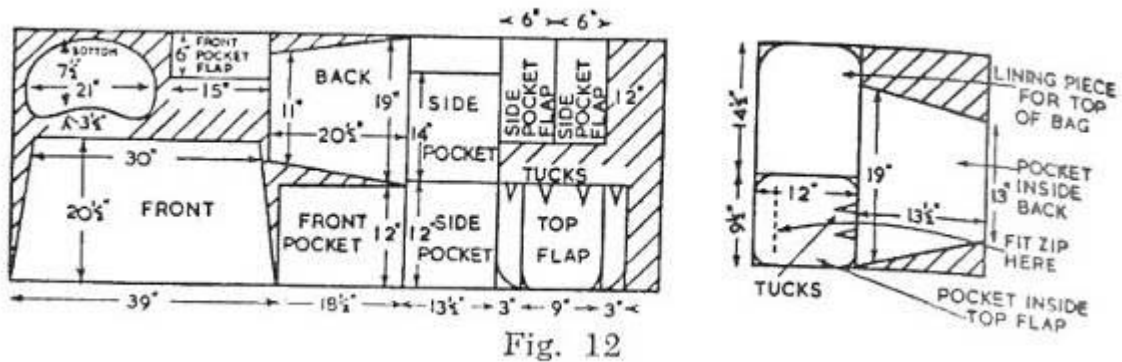

Fig. 12

The bag is made on the same lines as the soft rucksac previously described. Instead of hemming the flaps, however, these should be bound with 1 in. webbing. A band of 1 in. webbing is also sewn all the way round the bottom as an additional protection against wear.

The leather parts are fairly complicated, and it is suggested that the measurements should be taken from a borrowed rucksac. If you can obtain a piece of pebble grain chrome leather, as used for boot uppers, you will find that this makes satisfactory straps.

The bag should be given a coat of waterproofing to make it waterproof and to stiffen the canvas.



**Haversack** | The haversack is used as an additional pack on top of the rucksac for food, cook kit, toilet articles, etc., which may be needed on the journey. Tent rings can be sewn, at suitable places, on the rucksac, and haversack, to enable them to be lashed together with a short piece of guy line. The construction of a haversack follows the general lines of a single cycle “pannier”. (see Fig. 13)

**Panniers** (see Fig. 13) | The cyclist who does much camping should try to pack his kit on his bike rather than on his back. Panniers which hang on either side of the carrier are the most effective method.

An additional large haversack strapped on crosswise will house the remainder of the gear. Care must be taken not to obscure the rear light.

**Panniers**

Materials required: 42 in 9 oz. cotton duck, 32 in. wide  
 4½ yds. strong webbing, 2 in. wide  
 6 buckles, prong type, 2 in. wide

Cut the cloth in the following pieces:

2 pieces 32 in. by 16 in.  
4 pieces 16 in. by 5 in.

Take the large pieces and make hems C A B D and I J.

Cut the webbing into two pieces 37 in. long and two pieces 44 in. long and make two pairs of straps.

Sew the straps to the outer side of the large pieces, making sure that the short tongues and buckles correspond.

Take the small pieces and make hems N P Q and Q R O. Sew pieces of tape 10 in. long at Q.

Join up to small pieces, N L M O, to the large pieces at C E G I using French seams with the ridge outside, and similarly on the other side. A coat of waterproofing would be an advantage. When using the panniers it is a good plan to obtain a carrier which has a bottom bar, so that a strap can be passed round each pannier and round the carrier to hold all securely in place.

A webbing strap about 36 in. long and fitted with a pronged buckle can be used to convert one of the panniers into a useful haversack.

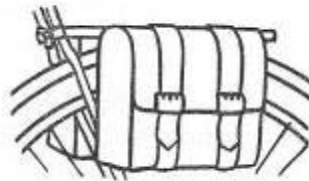

Fig. 13

**Trowel** | A small trowel is a useful addition to the hiker's kit. For preference it should be shaped like a little spade. This serves for turfing a fireplace, for digging a latrine hole and wet and dry pits. A garden trowel can be flattened and trimmed up, or the point can be ground off a small pointed trowel. Take a bit off the handle too while you are at it and make a light leather sheath for the blade.

**Knife, Fork and Spoon** | Choose the lightest you can get and provide a bag to hold them. A can opener and any loose pot handles should go in the same bag.

**Mug** | This is largely a matter of personal choice. Some of the pliable plastic ones are very convenient. Aluminum mugs get very hot and are likely to burn the lips. The enamel kind is still quite good, but don't try to get a bigger one than the other fellow. Half a pint is not such a bad ration after all.

**Plates** | The solo camper has no need for plates as he should be able to use his cook kit. If you take plates they should be small and deep rather than large and shallow, particularly for winter camping. The aluminum kind are lighter than enamel, but hot food placed on them gets cold very quickly.

**Stoves** | There are various makes of pressure stoves on the market and there is little difference between them.

**Windscreen** (See Fig. 14) | A pressure stove requires protection from wind. The screen shown is made from a piece of lightweight cloth and four umbrella ribs trimmed and shortened. A suitable place for packing the screen is around the tent poles.

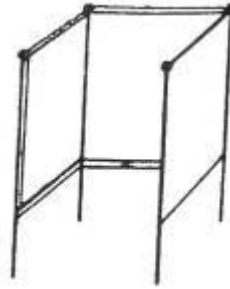

Fig. 14

**Illumination** | Candles can be used, but are not recommended because of the danger of fire and the risk of spilling the wax. If used they should be put into a holder or into a candle lantern. Electric lighting by means of flashlight suspended from the roof is safer.

**Guy Lines and Sliders** (See Fig. 15) | The cord commonly used for guys on lightweight tents is  $\frac{1}{8}$  in. diameter hemp cord with small aluminum sliders and rings to suit. Nylon cord can also be used and, though somewhat more expensive, has the advantage of not tightening up when wet, and it is mildew proof.

**Storm Guy** | Additional guys fitted with sliders and rings should be taken from the top of the poles to the ground and through the bottom roof rings to the ground on walled ridge tents, as an additional protection when camping in exposed places, or when the soil does not give a good grip for the pegs.

**Pegs** | Metal tent pegs are the only suitable type for lightweight tents. Those made of duralumin rod with large ring ends are the best. Meat skewers make good pegs, though somewhat heavier. The closed ring end is better than the open loop kind. A peg bag should be provided to keep the kit clean. A plastic bag protects the kit if pegs are wet when packed.

**Rings** | The rings in common use are of aluminum and are either "D" shaped when attached to the tent or "O" shaped for use on the end of a line. The  $\frac{1}{2}$  in. size is quite large enough for small tents.

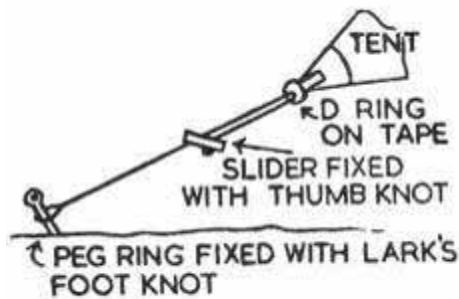

Fig. 15

**Stub Plate** | This is a metal disc about 2 in. in diameter with a depression in the centre. Its purpose is to prevent the pole from sinking into soft ground, and damaging the ground blanket.

**Repairs** | A small tin containing cottons, thread, darning wool, a small block of bee's wax, needles, pins, thimble, and scissors will serve for most of the repairs needed on personal kit or gear. A handkerchief sewn in place makes a good temporary patch if the tent gets a rip.

Some spare guy line should be packed for repairs or for use as a storm guy in bad weather, also an odd ring or two for similar purposes.

**Poles** | Poles made from aluminum alloy tubes which nest one inside the other are convenient for packing and very satisfactory to use.

Hardwood poles are the least satisfactory as they are heavy, the joints often swell and lock when they get wet, and if the wood is not straight-grained they will sometimes break.

A bag should be provided for packing the poles.

**Tents** | Tents vary considerably in design, quality of materials and quality of workmanship. Before you decide to get your own tent, try to see the model you prefer under actual camping conditions. If in doubt, ask the advice of an experienced camper.

The lightweight tent, if well made and properly cared for, will last for many years. When in camp, slacken the guy lines at night or when raining and brail up at reasonable intervals. When packing, see that all the insects which collect in the top are shaken out. Do not leave the tent rolled up wet for more than twenty-four hours. Shake it out loosely and get it really dry and aired before stowing. Do not pack articles such as meat skewer pegs with the tent as these can cause iron-mould or other damage.

A tent design usually starts as a rough sketch on paper, but the next stage is a scale drawing (about 1 inch : 1 foot) showing a plan and two elevations. A model is then made of thin card to the same scale. Overlaps are provided so that the various panels can be glued together and the ground line glued to a base made of strong cardboard.

Then draw to scale a long strip the width of the cloth you intend to use (tent cloth is usually 42 in. wide) and plan out the various panels so as to waster as little cloth as possible. The measurements for each panel can be taken from the scale model plus allowance for seams and hems. Having got this far, you will have a good idea of the weight of the tent.

The best material for tent making is finely woven Egyptian cotton of 100 or 120 threads to the inch, and weighing about 3 oz. to the square yard. Green, tan or similarly coloured material can be used, but white is not so good as it soils easily. Tape must be good quality linen tape about ½ in. or ⅝ wide.

Having made the strip plan as previously described, or by taking measurements from a borrowed tent of the required design, mark out the panels on the cloth itself in tailor's chalk to avoid mistakes. Join the panels together with a run and fell seam. (See page 81.) It is not necessary to turn the rough edge in if the seam is to be strengthened with tape. Tapes must be sewn inside the tent either over the seams or directly to the tent cloth to take the strain from guy lines and rings.

Patches of doubled pieces of tent cloth should be sewn on where rings are to be fixed. Patches of linen cloth about 6 in. diameter together with slightly larger patches of doubled cloth should be sewn on at points of heavy strain. These will be required where the main guy lines are attached and also at the top of the pole. Pole openings are finished off inside with a circle of soft leather about 2 in. diameter and outside with a metal ring of suitable diameter. The ring is oversewn with stout thread which passes



through the leather and the cloth patches and down through the ring again. Patches of double tent cloth should also be sewn in corners and other similar points where strain will arise.

**Equipment** | An electric sewing machine, if available, is preferable to the foot or hand operated ones. Use a fine needle such as the Singer No. 14. Sewing cotton should be as strong as possible. The No. 40, 6 cord is quite suitable. A hem gauge fixed to the base of the machine helps to keep the hems even.

**Cutting out Panels** | When a pair of triangular panels have to be cut out, it is better to cut the two together as a rectangle first and then to fold diagonally and cut along the fold to separate.

**Preparation for Sewing** | It is essential that all joints should be well pinned together before sewing.

**Seams** | The seam commonly used for joining panels is known as “run and fell”. This is made as follows:

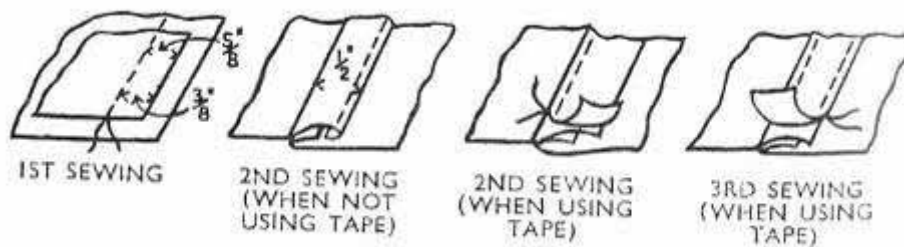

Fig. 16

**Hems** | The most common hems are the following:

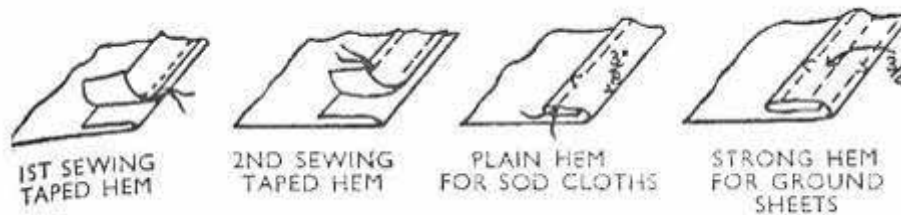

Fig. 17

**Patches** | The patches of double tent cloth used at points of strain vary in shape. A triangular one, for example, is made from a piece of tent cloth about 4 in. square, folded diagonally and having the rough edges turned under. It should be sewn in place under the corresponding hem or hems with extra lines of sewing as shown.

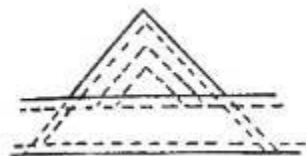

Fig. 18

**Rings** | The “D” ring is attached to the roof of the tent with a piece of tape about 5 in. long folded as shown. This is then sewn to the patch on the tent with extra lines of sewing.

“D” rings on the ground line should be sewn through the tapes and patches with strong thread.

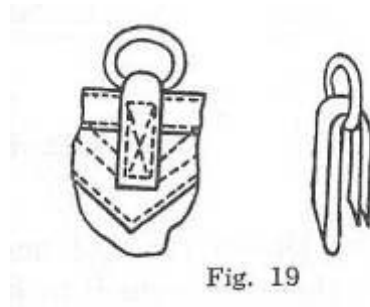

Fig. 19

**Guy Lines** | It is recommended that guy lines should be rigged as shown. The double portion being at the top enables adjustments to be made easily and the ring for the peg prevents undue wear on the cord. The double portion should be about one third of the length from the tent to the ground.

**Tent Types** | The "A" or "Bivvy" is the simplest kind of tent. The size given is suitable for the solo camper.

Dimensions: Length 6 ft. 9n in. width 4 ft.  
Height 4 ft.  
Weight of tent: 2 lbs.

Materials required: 10 yds. Egyptian cotton, 42 in. wide  
36 yds. linen tape, 1/2 in. wide  
9 yds. guy line 1/8 in.  
4 sliders  
4 "O" rings 1/2 in. size  
15 "D" rings 1/2 in. size

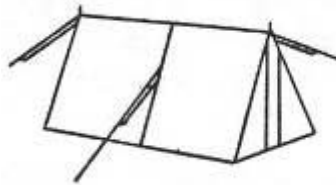

Fig. 20

The cutting plan for the cloth is as follows:

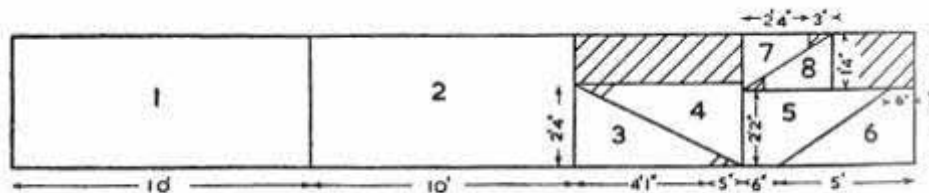

Fig. 21

Parts marked // are waste. Put them aside for patches.

Make up the roof by joining pieces 1 and 2 along the selvages and tape over the seam from E to K. Sew patches of double tent cloth at D E F J K L and halfway along E H and H K if the side guy line is to be used. Sew patches of linen and double tent cloth at G and I. Sew tapes D E F, G H I and J K L. Hem the edges of the sod cloths tapering off the ends.

To make the back, join pieces 5 and 6 along A C. Sew patches at A B C and D and tape B D. Hem sod cloths and taper off the ends, leaving a slit at F C G.

Make up the doors by joining pieces 3 and 7 and 4 and 8. Sew patches at A C D and F and tape D F, B D and A E.

Join back and doors to the roof and tape seams.

Finish off pole openings, sew on rings and door tapes and fit guy lines to complete. The main guys are 3 yds., and the side guys 1½ yds. long.

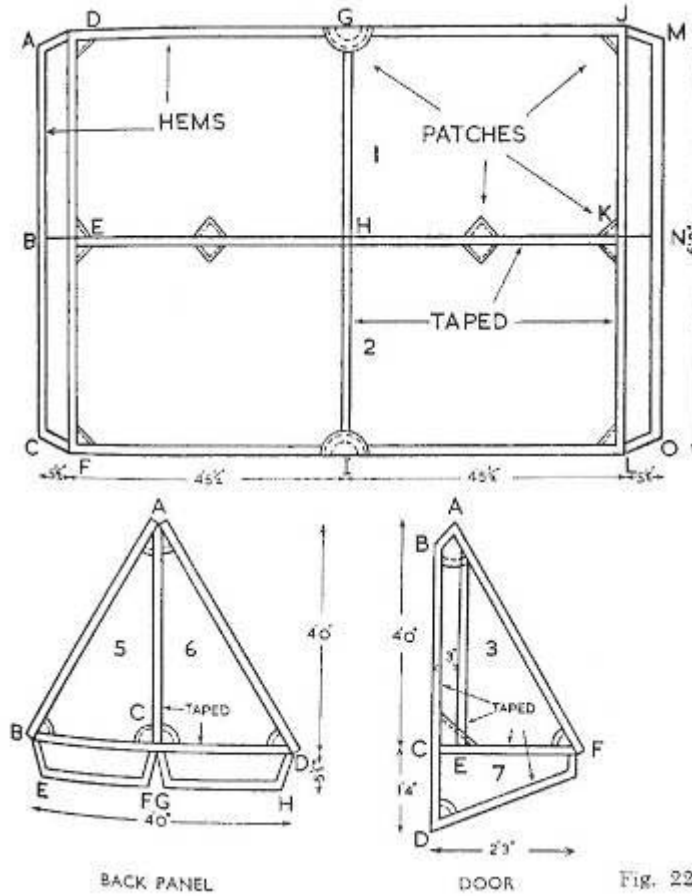

Fig. 22

**The “Alaskan”** | This is a tent which has a fine reputation, although it was designed many years ago. The small size shown will take two campers.

Dimensions: Length 6 ft. 9 in., width 4 ft.  
 Porches 1 ft.  
 Height 4 ft. 3 in., walls 1 ft. 6 in.  
 Weight of tent: 3 lb. 6 oz.

Materials required: 15½ yds. Egyptian cotton, 42 in. wide  
 48 yds. linen tape, ⅝ in. wide  
 14 yds. guy line, ⅛ in.  
 12 sliders  
 12 “O” rings, ½ in. size  
 26 “D” rings, ½ in. size

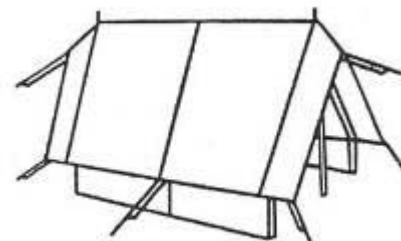

Fig. 23

The cutting plan for the cloth is as follows. If doors are required at both ends, take out pieces 13 and 14 and put in two more like 11 and 12.

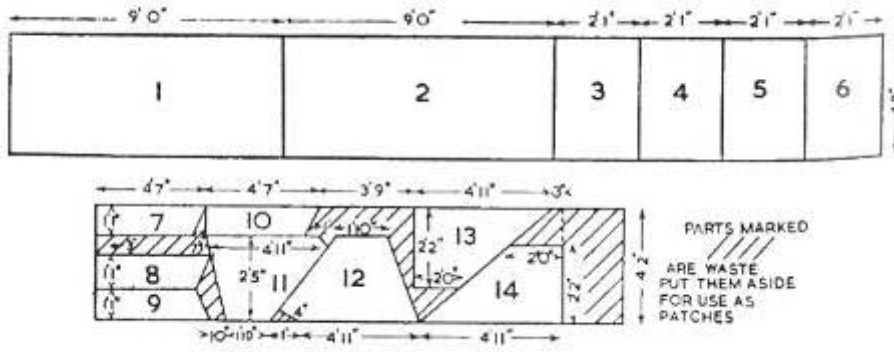

Fig. 24

**Roof Plan** | Make up the roof by joining pieces 1 and 2 along the selvages, also join on pieces 7, 8, 9 and 10. Sew on patches of double tent cloth at all points A to H and O to V and linen and double cloth patches J and N. These pole patches should not be sewn right up to the edges of the “vees” I J K and L N M and sufficient space should be left for finishing them off when the edges of the “vees” are joined up. Sew tapes on B J S, C T and D N U. A tape long enough to cover the whole of the ridge seam should be sewn along J N and over the end seams when these are made. Complete pole patches. Sew patches of linen and doubled cloth at outside edge of “vees” and sew down the ends of the ridge tape. Hem and tape all round the outside edge. Mark the lines F G H and O P Q, 3 ft. 4<sup>3</sup>/<sub>4</sub> in. from the centre line J N. Make up the walls by joining pieces 5 and 6 along selvages. Sew on patches. Sew on tapes B E and D E F. Hem round sod cloth tapering off the ends. Join the walls to the roof by placing the edge C B A nearly up to the line F G H with the wall itself extending over the eaves. A line of sewing should then be made about 1/4 in. from the F G H. Make up doors and back panel as shown in diagrams. Patches and tapes will be required in the same way as for those of the “A” tent. The next step is to sew in the back panel and also to sew doors to the roof and walls and tape over seams. Finish off the pole openings, sew “D” rings on tape to the roof and direct to the tent on the ground line. Sew tapes to the doors for holding when rolled up and for fastening when closed. Fit guy lines and sliders. The main guy lines are 4 yds., the corner ones are 3/4 yd. and the other 1/2 yd. long.

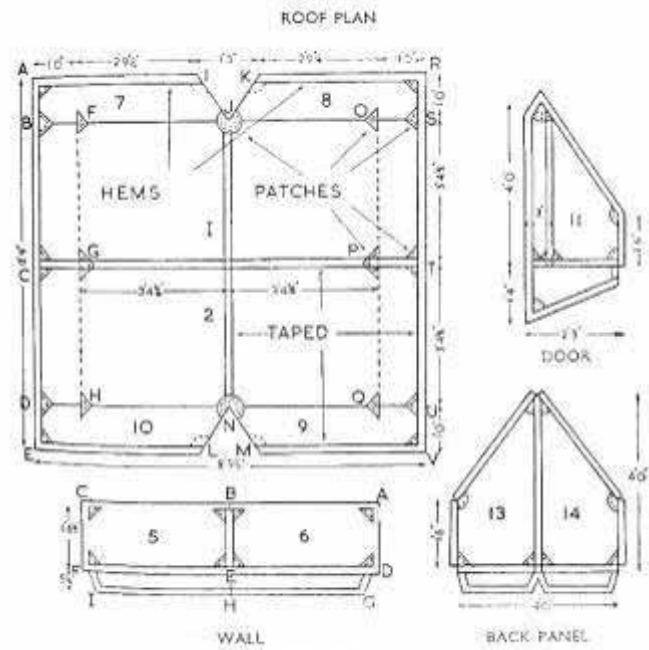

Fig. 25

**The "Senior" (Itisa Type) Tent** | The original "Itisa" was designed by Camping Club members of Great Britain as a solo tent, more than thirty years ago. This more recent development is suitable for three adults or four boys. A fly sheet is desirable in bad weather.

Dimensions:           Width 7 ft. Back to front 6 ft. 3 in.  
                               Height at pole 5 ft.  
                               Height at front 3 ft. 6 in.  
                               Weight of tent: 3 lb.

Materials required:   15 yds. Egyptian cotton, 42 in. wide  
                               45 yds. linen tape,  $\frac{5}{8}$  in. wide  
                               12 yds. guy line,  $\frac{1}{8}$  in.  
                               10 sliders  
                               10 "O" rings  
                               23 "D" rings

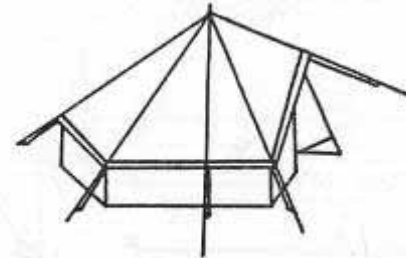

Fig. 26

The cutting plan for the cloth is as follows:

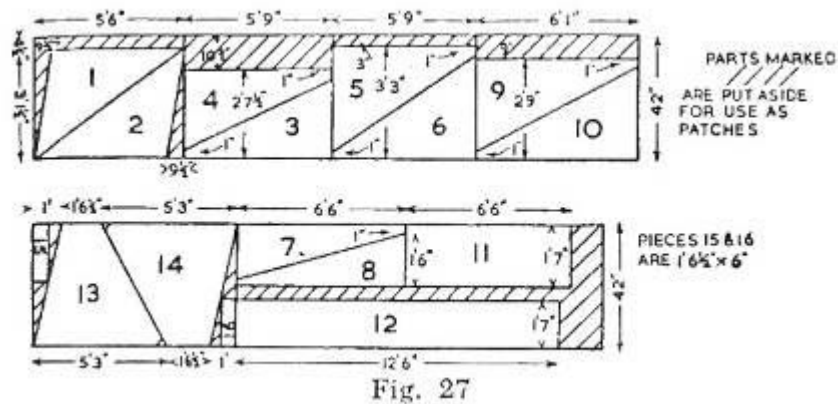

Fig. 27

First make up the roof working each side alternately and taping each seam as it is made. Start by joining panel 3 to panel 1, then panel 4 to panel 2. Pick up 1 and 3 and add panel 5 and similarly add panel 6 to 2 and 4. Join panels 7 and 8 and 9 and 10 to their respective sides and then make the back seam which joins the two sides together.

Sew on the strengthening patches of double cloth and the pole patch of linen and double cloth. The latter should not be sewn right up to the edge and sufficient space should be left for finishing off after the front seam has been made. This is now done and, after taping the seam, a patch of linen and double cloth is put on to take the pull of the front guy line. Hem all round the outside edges and tape over this hem. Next, mark the wall line of the roof.

Make up the walls in one strip with patches and tapes along the ground line and down tapes to correspond with the roof tapes. Also hem the sod cloths. Join the walls to the roof by placing the top of the wall nearly up to the wall line marked on the tent with the wall itself extending towards the centre of the tent. A line of sewing should then be made about  $\frac{1}{4}$  in. from the marked wall line. Then fold the wall outwards over the eaves and sew again along the marked line so as to enclose the rough edges.

Make up the doors with patches and tapes and sew them in place. Then tape over the seams. Finish off the pole opening, sew "D" rings on tape to rood and direct to tent on ground line. Sew tapes on doors for holding when rolled up and for fastening when closed. Fit guy lines and sliders. The main lines are 15 ft. long and the others are 2 ft. 4 in.



**The “Super Senior” Fly Sheet** | Although comparatively light in weight, the senior tent fitted with this type of fly sheet begins to get heavy for the “all on your back” camper. Shared between three, however, it is not too bad. Such a fly sheet does provide a great deal of additional shelter and makes a very convenient dining space for a small party. It is also ideal for the Scouter or the family man.

Materials required: 17½ yds. Egyptian cotton, 42 in. wide

60 yds. linen tape, ⅝ in. wide  
 20 yds. guy line, ⅛ in.  
 12 “O” rings  
 12 “D” rings

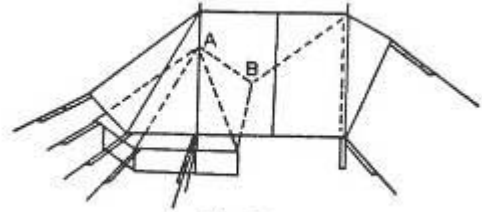

Fig. 30

The cutting plan for the cloth is as follows:

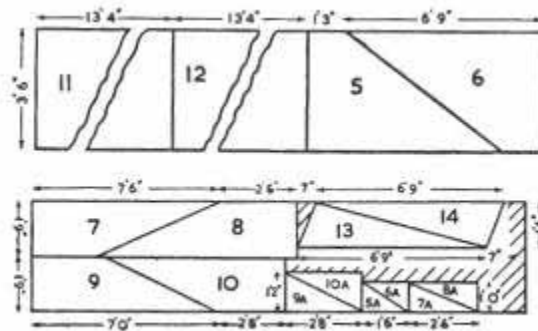

Fig. 31

The fly sheet is made by completing panels 5, 7, 9 and 6, 8 and 10 with their little triangles and joining them together to complete the backs as for the “Senior” type. Panels 11 and 12 are joined together and the porch panels 13 and 14 are put on. All seams and hems are taped, and the pole patches, rings, etc., are fitted as already described.

The guy line lengths are as follows, working from centre front to centre back: 12 ft., 4 ft., 3 ft., 3 ft., 4 ft., 4 ft., 3 ft.

When using this type of fly sheet, the front seam of the tent (A B) should be fitted with a zip fastener which enables the front panels to be rolled back. Guy lines should be fitted as shown in the sketch.

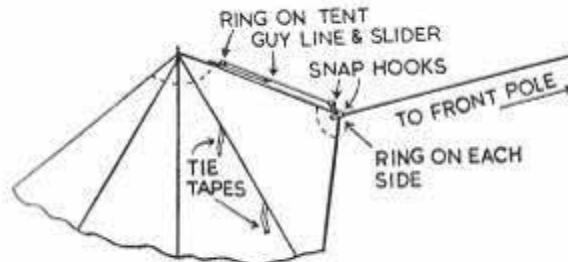

Fig. 32

**The “Cairngorm”** | This tent was designed to give reasonable comfort under all conditions for one or two campers and at the same time to keep the weight as low as possible.

Dimensions:            Height: Front 3 ft. 6 in.; at pole: 4 ft.; back 2 ft.  
                              Width: Front 5 ft. 3 in., back 2 ft. 6 in.  
                              Weight of tent: 2 lb. 4 oz.

Materials required:    10 yds. Egyptian cotton, 42 in. wide  
                              12 yds. guy line, 1/8 in.  
                              10 “O” rings  
                              36 yds. linen tape, 5/8 in. wide  
                              10 sliders  
                              27 “D” rings

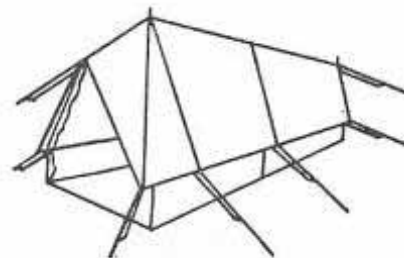

Fig. 33

The cutting plan for the cloth is as follows:

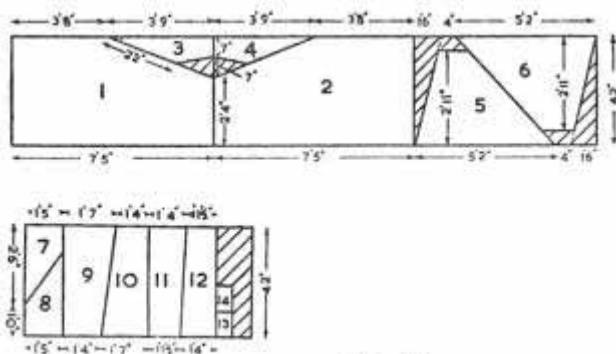

Fig. 34

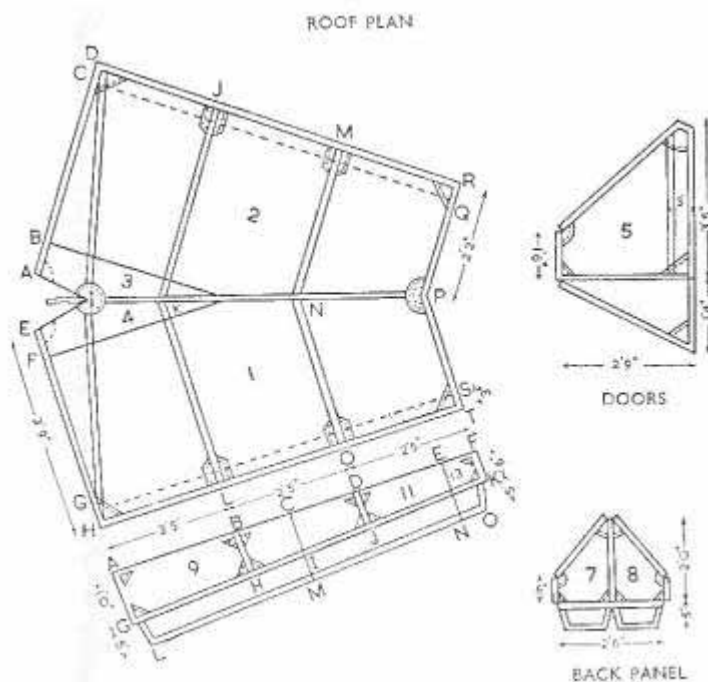

Fig. 35



Make up the roof by joining panels 1 and 4 and 2 and 3 with run and fell seams. Join the two sides together and tape the seam. Enough tape should be left to complete the front of the ridge. Sew tapes to cloth at H I, D I, L K, J K, O N and M N. Sew patches of linen and double cloth as shown on the roof plan. Finish off the front ridge seam, and sew a strong patch where the front guy line will come. Make a hem all around the outer edge, taping the parts G H L O T S and C D J H R Q. Mark out the wall positions G S and C Q in chalk.

Make up the walls by joining panels 9, 11 and 13 and 10, 12 and 14. Sew on patches and tapes and hem sod cloths. Sew the walls to the roof by placing the edge of wall A F nearly up to the line G S with the wall extending outwards from the ridge. Make a line of sewing about 1/4 in. from G S. Fold the wall over on to the roof and sew along the line G S. Make up the back panel and doors with tapes and patches as per diagrams. Sew the back panel and doors in place and tape the joins. Finish off the pole openings, sew rings on tape to the roof and direct to the tent at the ground line. Sew tapes to hold the doors back and to fasten them when closed. The guy line lengths from centre front to centre back are 14 ft., 2 ft., 6 in., 2 ft., 2 ft., 2 ft., and 4 ft.

**The "Cairngorm" Fly Sheet** | The making of the fly sheet is very similar to the procedure for the tent roof. Work from the cloth cutting plan and the half plan below in the manner described for the tent.

- Materials required:
- 8 yds. Egyptian cotton, 42 in. wide
  - 20 yds. linen tape, 5/8 in. wide
  - 12 yds. guy line, 1/8 in.
  - 10 sliders
  - 10 "O" rings
  - 10 "D" rings

The cutting plan for the cloth is as follows:

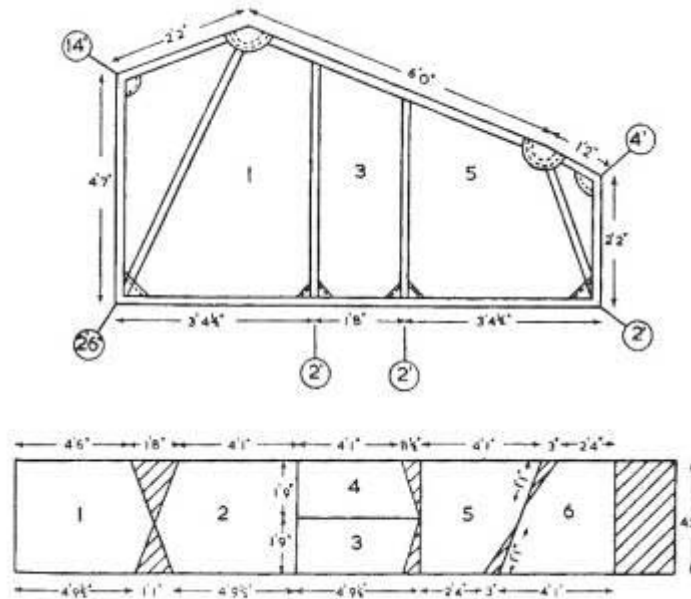

Fig. 36

The lengths of the guy lines are shown in the small circles.

**Windscreen** |

Materials required: 8 yds. Egyptian cotton, 42 in. wide  
4 umbrella ribs

Hem the cloth on the long sides, then make hems at the ends and tucks at equal distances to form pockets for the umbrella ribs. The ribs should be stripped of pivots and shortened to about 16 in. Place the ribs in the pockets in the cloth and sew in place.

**Toilet Articles** | A case to hold soap, toothbrush, paste, razor, comb, mirror, etc., can be made from an oddment of leather or canvas. Look for a small container to take only enough soap for the camp. Shaving soap as well as washing soap is not needed. Use one for both purposes. Similarly, a whole tube of toothpaste is not needed and if you can find an end at home with an inch or so left in it, it will last for several camps.

**Waterproofing Clothing** | A waterproof coat is essential to comfort in conditions where the drying of clothing is difficult. It may be made at home of lightweight cloth proofed when finished with the oil mixture recommended for ground sheets (see "Waterproofing"). Waterproof leggings and a sou'wester are valuable garments for very wet weather. Plastic raincoats are very light and thoroughly waterproofed, but tend to tear easily.

**Waterproofing** | The various solutions and compounds can be divided into two kinds.

(1) Water repellents, which do not close the pores of the material and which cause water to roll off the fibres. This kind is excellent for tents and affords some protection when used for clothing. It should be made up as directed and painted on the tent when it is pitched. Commercial brands should be used rather than any home-made mixtures.

(2) Waterproofing mixtures, which close the pores of the material. The following waterproofing mixture is strongly recommended for ground sheets: 2 parts boiled linseed oil and 1 part turpentine.

The two liquids should be mixed together and applied with a paint brush to the ground sheet, which is hung on a line and kept taut with weights. The mixture should be worked into the cloth with the brush without leaving a surplus on the surface. Apply to one side only and see that no water falls on the cloth during drying, which will take two or three days. One pint of the mixture covers 6 to 8 square yards of fine cloth. Heavier cloth takes more.

### *Quest No. 22 — Fitness*

Scouting has always aimed at healthy living through training. It has made a definite contribution in the past which must be continued and intensified in the present and the future.

**Definition of Fitness** | Contrary to popular belief fitness is not merely good health. Fitness is good health plus a wholesome outlook on life. Fitness is desirable in order to get the most out of life, and to be able to give the most to better community living.

In their study of citizenship Rovers are concerned with the whole general question of fitness, and should realize the importance of their own and other peoples' interest in keeping fit. To be fit is to "be prepared".

For convenience, the subject of fitness may be divided into two categories — physical health — mental health.

In physical health we are concerned with knowing how to live in our environment, how to develop strength and stamina, how to take care of our bodies, and develop habits and practices that will keep our bodies in good working order all our lives.

When we speak of mental health we are concerned with developing balanced thinking, a feeling of personal security, and emotional maturity; in other words, the achievement of a well-balanced personality.

**Physical Health** | It would appear that most young men take for granted that they are physically fit, and give little thought to the consequences that will affect them in later years because of poor physical habits.

It is very necessary for every Rover Scout to realize the importance of fitting his own body for the job it will be expected to do all his life. All too often a young man is inclined to exercise and develop those parts of the body and those abilities in which he feels pride, and his weak points, which should be developed, are neglected. To overcome this tendency Rover Scouts should be encouraged to have periodic medical check-ups, and to rely upon medical advice for good body development.

**Rest** | In order that the body's recuperative powers may have the opportunity to function efficiently it is essential that sufficient rest be obtained. At early Rover age, the individual has not stopped growing and requires at least nine hours of rest each night. Even when all growth has stopped, eight hours of sleep are recommended.

Crew activities — camps, socials, meetings — must take this factor into consideration when programmes are being developed, and the Rover Scout Leader must bring this to the attention of the Crew if it is overlooked.

**Exercise** | Rover Scouts must be made aware of the importance of personal exercise. True, this is usually an individual matter to pursue or reject, but interest might be stimulated and strengthened by the whole Crew going in for some system of exercising with the help of a properly qualified instructor. In time, various members of the Crew may be able to qualify as instructors themselves, and they in turn could render a useful service to Troops and other Crews.

Young men are usually quite concerned with muscular development, and because they have been conditioned by advertisements they are quite envious of an Atlas-like physique. However, they should be made aware of the fact that it is just as important to develop agility rather than brawn, and staying power than big but short output.

There are all sorts of activities which exercise the body, and the Rover Scout Leader should do his best to encourage every Rover Scout to take pride in his own fitness by participating and not being merely a spectator.

As has been said, formal physical exercises are one form of exercising the body. The general scheme of team sports is another. Walking, running, swimming, cycling, rowing, archery, rope spinning, folk dancing, boxing, bowling, judo, gymnastics, curling, badminton, tennis, fencing, hiking, mountain or rock climbing, golfing, are other activities of an individual, or team nature, which should also be considered. Somewhere in this list there is an activity to suit every Rover. The main thing is to make sure that every Rover does participate in some activity to give his body exercise and movement. It is also important to expose each Rover to a sport, such as golf or fencing, to arouse interest in a sport that would be useful in later life when teen-age sports are left behind.

A Rover who joins some athletic club, or team, may look upon this as part of his Rover work. (There is no need to detach himself.) It is better that the Scout ideal should be portrayed in a number of clubs rather than become concentrated in the Crew itself.

Where athletic clubs do not exist, or where Rovers are not participating in any form of organized sports, serious consideration should be given to the formation of Rover teams in order to provide play for those who would like to participate in organized sports. Team games of all kinds have a value beyond mere physical activity, but only when the play and atmosphere are clean.

Exercise, or whatever form, must be regular; otherwise the urge to be fit may become lost. Therefore, it is good to encourage each Rover to form some daily habit of exercising all parts of the body.

**Food** | Eating habits are formed at home, and by the time a young man enters the Crew his likes and dislikes and attitudes towards food have been fairly well established. The Rover Scout Leader will have many opportunities to observe the dietary habits of his Rovers, and if it becomes obvious that these habits are not all that they should be, steps may be taken to correct the situation.

The Rover Scout Leader should be tactful in his approach. Perhaps the best way is to let the subject arise quite naturally when menus are being planned for a camp or hike. The Department of Health and Welfare of the Canadian Government issues many excellent pamphlets and booklets on the subject of nutrition, and most of them are free for the asking. Make use of this excellent service. Suggest to the Crew that a dietician, health officer, or doctor be invited to give a demonstration and talk to the Crew. In this way expert advice becomes available.

It is also important that the practices of the Crew both indoors and outdoors concerning the choice and use of food should set a good tone. For example, if it is the practice of the Crew to serve refreshments at the conclusion of a Crew meeting, wholesome and nutritious food should be served, rather than a constant round of soft drinks and sweet foods.

Many young men develop a practice of hanging about a neighbourhood restaurant, consuming large quantities of soft drinks, candies, and other sweet foods. The high percentage of sugar in these items creates ideal conditions in the mouth for the growth of bacteria which secrete acids which do great harm to the teeth. Rovers should be discouraged from taking too much of this type of food on hikes and rambles and encouraged to take along fresh fruit to allay the pangs of hunger or thirst.

To be a good camper a young man must be a good cook. It is not sufficient to know only the types and amounts of food necessary for a balanced diet. It is necessary to know how to prepare food properly. Good food badly cooked is no longer good food. Considerable training may be required to teach young men how to be good camp cooks.

As a general rule, practical, plain and sufficient food is a good guide. However, we should not be content to leave the culinary art at that level. There can be adventure in eating. The preparation of unusual foods, and various national dishes should be considered. Various methods of cooking should also be tried. There is a tendency to sauté everything. Experiment with planking, baking, roasting, boiling, stewing and cooking without utensils.

Rover Crew may have a lot of fun experimenting with dehydrated foods and other forms of lightweight food stuffs. They can render a very valuable service to their Troop by thoroughly investigating and informing the Troop through the Court of Honour of the results.

**Fresh Air and Sunshine** | The values of fresh air and sunshine are now universally known. However, we still find many who will sleep in a room with very little circulation of air, campers who will tightly lace themselves into a crowded tent at night, and Crews that prefer the stale air of a den to the out-of-doors.

There will be many occasions when the Crew will be on tour and may stay in cabins or tents. This presents the situation where the Rover Scout Leader may promote good fresh air practices.

It is a good practice for the Den to be thoroughly aired before a meeting begins, and to provide for a circulation of air during the course of the meeting by leaving a window or door open.

Direct sunlight supplies essential vitamins, and sunlight is particularly valuable for the prevention and cure of diseases. However, moderation must be observed as there are dangers other than sunburn in sudden immoderate exposure to sun and fresh air. There are some diseases which react unfavourably to direct sunlight.

A Rover Crew following normal Crew activities will take Rovers out into the open air frequently, and the benefits of fresh air and sunshine will automatically become a part of their activity.

**Clothing** | Generally, young men of Rover age are quite conscious of dress. The latest fashion in men's wear receives much attention.

When engaged in physical activity, such as hiking and camping, clothing should be simple, sensible, and comfortable. Sturdy, properly fitted shoes are essential for hiking. One heavy pair, or two light pair of woollen socks, well fitted, and free from lumps are also an aid to comfort and health. Shorts are ideal for hiking and general camp use, but in black fly, mosquito or deer fly country, or if an individual is susceptible to sunburn, slacks become necessary.

When a person is engaged in vigorous physical activity the clothing next to the skin soaks up perspiration, and when the physical activity ceases, the perspiration evaporates and the wearer becomes chilled. Either an extra shirt should be available to change into, or else a warm sweater should be donned to let the wearer cool down slowly. Headgear should be of a type to protect the eyes from glaring sun and from twigs and brambles when going through the bush and to help prevent rain from running down the neck.

For winter the same general principles as stated above apply, but of course there is need for modification. First of all, windproof and showerproof outer garments are necessary for comfort and health. A sturdy waterproof overboot is essential. Ski-type slacks are sensible and comfortable. The jacket should be of a type with an adjustable draw-string at the waist which may be tightened or slackened to regulate air circulation to control the wearer's body temperature. The secret of warmth is to keep cool without being cold. A string undervest will help control body temperature. Headgear should have some form of ear covering for protection against wind and frostbite. Mitts should be wind and waterproof and must not fit too tightly.

The official Rover Scout uniform together with the optional articles of wear have been designed to conform to the above requirements.

By wearing functional clothing on Rover Scout activities young men begin to realize the necessity of dressing for health and comfort. This is a valuable lesson that they can carry with them into their adult life.

**Cleanliness** | Physical cleanliness is of great importance to good health. Most Rovers will be aware of this fact and will know what measures are necessary to keep all parts of the body clean. They learn this at home and in school. However, in spite of knowledge, there may be a tendency on the part of some Rovers, particularly the young Rovers, to ignore some practices of cleanliness.

The Rover Scout Leader may have opportunities to notice that some Rover has offensive breath or body odours. This may be simply a matter of forgetfulness to clean the teeth or bathe the body. The Rover Scout Leader is doing the offending Rover a favour by privately drawing this to his attention.

While camping or hiking there may be a tendency to bypass usual habits of cleanliness. A swim may be considered all that is necessary, whereas a wash with hot water and soap, is really necessary to clear the pores of the skin which have been blocked by natural perspiration. If water is at a premium, a sponge-down will do the job, or even a rub-down with a rough towel. It is particularly important that those handling food observe proper rules of cleanliness.

Clean clothing is necessary if the body is to function properly.

Cleanliness in the Den, while camping, care of the uniform and equipment, as well as cleanliness of the body, all have an influence on the proper observance of the tenth part of The Scout Law.

**Family Life Education** | The broader term Family Life Education is preferred, rather than the narrower term of sex education. Family life education not only includes the subject of the reproductive process, the basic physiological information, but also the whole field of man-woman relationships such as dating, going steady, marrying, and supporting a family. It is the Rover Scout Leader's job to help the young man to establish those habits, attitudes, and ideals of life, which may in the future contribute to a well balanced, mature, and happy family relationship.

However, before any family life education is attempted, the need for it must be apparent, and the Rover Scout Leader must know the young men well.

A proper understanding of sex is an integral part of a young man's education. By the time a young man enters the Crew he may have a thorough idea of sex as a function of the body. Some will not. However, in all probability he will have little idea of the function of sex as an emotion which must be understood, directed, and controlled. He still has to develop standards of value that will enable him to distinguish what is good in sexual life from what is sordid, selfish, or perverted.

The Rover Scout Leader must stand ready to help his growing Rovers to face and solve some of the dilemmas of conduct that must be met in early boy-girl relationships. If a proper attitude has been established between the Rover Scout Leader and the members of his Crew, it is more than likely that the subject of sex will be raised by the Rovers themselves without any prompting on the part of the Rover Scout Leader. This is as it should be.

The Rover Scout Leader's treatment of individual cases will differ according to the character and circumstances of each young man. However, some collective teaching can be done and this should be short and to the point. It should be given by one who thoroughly understands the subject — preferably the Rover Scout Leader himself who should make it his business to acquire the necessary understanding. The Rover Scout Leader should attempt to provide an adequate vocabulary of sex so that discussion may be carried on without resort to vulgar terminology.

Some authorities on the subject of family life education disapprove of emphasizing the ravages of venereal diseases. The subject of V.D. should not be introduced in isolation from the whole subject of

family life education, but only as part of the education. Similarly, many authorities feel that by having a doctor or some other stranger attend especially to give a talk on sex lends an undesirable “special” atmosphere to the topic.

Talks on family life education should be given in a manner similar to the talks on any other normal subject. When completed the subject should be brought to definite conclusion, and unless some new aspect of this subject needs to be aired, it should not be repeated.

If the subject of family life education has been presented in a proper manner it will ultimately lead to related subjects such as buying a home, life insurance for the family, family allowances and family relationships.

**Mental Health** | What is good mental health? It may be defined as “that state which permits an individual to realize the greatest success which his capabilities will permit, with greatest satisfaction to himself and others”. In other words, it is the ability to live effectively with oneself and others.

One of the most important objectives of Rover Scouting is to develop men who are emotionally mature. It has been said that if there were enough mature people in enough countries of the world there would be no wars.

Much has been written about emotional maturity, and a Rover Scout Leader should have some acquaintance with contemporary literature on the subject. For our purposes here, it would be difficult to set down in a summary form the “rules” of emotional maturity. Perhaps instead, it can be put this way. One of the things which may prevent an individual from achieving emotional maturity is an inability to obtain satisfaction for his psychological needs. What are these needs? They are the needs for affection, achievement, belonging, recognition, independence, and self-esteem. It is a commonly held belief today that starvation of these psychological needs may lead to the inability to cope with life, instability, and even physical illness.

Needless to say, the Rover Scout Leader must be aware of his own psychological needs, and must himself be emotionally mature if he ever hopes to be in a position to help others.

There are a number of things a Rover Scout Leader can do to try and meet the needs of his Crew members.

He can perhaps meet the need for affection by offering genuine friendship and lending a sympathetic ear to individual problems.

The individual's need for achievement can be served by making certain that every Rover undertakes and carries through with an individual Quest.

Actual participation in Crew life can give a sense of belonging if the Rover Scout is made to feel that he is an important member of the group.

Recognition can be given on many occasions, perhaps in actual ceremonies, or by being thoughtful enough to let other members of the Crew know when an individual has done well in school, or has received a promotion at work, or has done something which merits public approval and recognition.

The needs for independence and self esteem can be met by making certain that the voice of each Rover is heard and his outlook and individual views given serious consideration.

The Rover Scout Leader can assist his Rovers to maintain a high standard of mental health by encouraging them to:

1. Maintain good physical health
2. Seek satisfaction in work
3. Do some reading or studying in connection with their work
4. Have a hobby
5. Have social contacts outside of work and outside of Scouting

**Alcohol and Tobacco** | This particular phase of fitness has been placed under the sub-heading of mental fitness rather than physical health because the attitudes towards, and the habits in regard to the use of alcohol and tobacco, are usually developed at this time of life. Any damaging physical effects due to the excessive use of tobacco and alcohol may not yet be too apparent at the Rover age.

There are moral aspects to these social problems, but they will not be considered under the subject of fitness.

Because smoking and drinking are symbols of adulthood it is natural for young men to drink and smoke to prove that they are men. The Rover Scout Leader will be interested to know that of all the chronic alcoholics surveyed in one Canadian community 15.9% were between the ages of 20 to 29. Authorities also tell us that it takes from ten to twelve years to develop an alcoholic. Again, in a survey of a Canadian community it was shown that 40% of all 18-year-olds do drink. The quantity consumed was not tabulated. However, it was also shown that 22% of all 14-year-olds have had a drink.

From the point of view of instruction in mental health then, the Rover Scout Leader should take advantage of every opportunity for discussing drinking and smoking with members of his Crew. The subject of drinking and driving is usually given much publicity particularly around Christmas and New Year's. This might be a good time to bring the subject into the open, and not only the personal and hazardous aspects discussed, but also such things as liquor laws and controls, outlets, taxes, and related subject. Another worthwhile programme could be built around a speech by a qualified person in the field — a medical doctor, psychiatrist, or social worker, followed by a period in which questions could be raised and examined, as for example: Why do people smoke and drink? What are the reasons for excessive smoking and drinking? Why are they harmful? Open discussion of questions like these with an expert could be most instructive and rewarding for a group of young men.

It would be impossible and unwise for a Rover Scout Leader to forbid smoking and drinking. It is the law of the land to prohibit the serving of alcoholic beverages to minors, and the Rover Scout Leader, as a law abiding citizen, must observe the law and actively encourage his Rovers to obey this law, where it is in his power to do so. But the Rover Scout Leader cannot be biased in his attitude towards smoking and drinking. His job is to help the members of his Crew to understand the uses and misuses of alcohol and tobacco. Armed with such information, each individual can then develop a code of conduct and a set of habits which will sustain him in life.

### *Quest No. 23 — Living With Others*

This subject is closely related to that of fitness, particularly mental health. This thought must be kept in mind as we attempt to lead young men to develop a well-rounded personality which will grow with them as they mature.



**Parents** | In the lower age range parents may be a real “problem” to young men. Each young fellow “feels” that his weekly allowance is small in comparison to that which his friends receive. He “feels” that he has more chores, has more restricted hours and has generally more restrictions than his friends. Some of these complaints may be real, but many may be imaginary.

The main point to consider is that these are “feelings” that arise because he is maturing and starting to think for himself. However, the young man has not reached that stage of maturity where he can always distinguish fact from fiction. It is the job of the Rover Scout Leader to help his young men understand their relationship to their parents.

Problems such as the following might be discussed at Crew meetings among the Rovers themselves, and on occasions with the parents present — weekly allowances, chores about the home, how many nights out, late hours, questionable friends and places, borrowing the family car and spare time work.

As the members of the Crew grow older these will cease to be personal problems, either because the young men have learned how to solve them, or because they have gained enough independence by reason of their age that they are no longer problems. However, new considerations arise. Getting along with the girlfriend’s mother and father (perhaps the new parents-in-law), is important.

**Brothers and Sisters** | Getting along with brothers and sisters is another situation that may be worthy of consideration by the young men in the Crew. By discussing topics as teasing and quarrelling, sharing the household chores, monopolizing the telephone, baby-sitting, and taking sister to the party, young men may learn to establish some form of rational relationship with their older and younger brothers and sisters.

**Friends** | With young men of Rover Scout age the circle of acquaintance is rapidly expanding. In addition they now find that girls are coming into their circle of friendships, and at times they just do not know how to cope with some situations. For example, a fellow may find that his best friend, with whom he had been planning some activity, reneges in favour of going somewhere with a girl. The young fellow who is shy, may find it difficult to ask a girl for a date, or even ask a girl for a dance at a party.

Very often cliques of boys and girls are formed, and in spite of his wishes, a young man may be left out, and so feels rejected.

Some subjects such as hitch-hiking, wallflower versus wolf, going steady versus multiple dates, gossiping, bad temper, cheating, questionable friends and places, cliques and snobs are suitable topics for discussion among members of the Crew. At times, it may be a good idea to bring along the girlfriends, or an organized group of girls, to enter into discussions about boy-girl relationships.



**The Democratic Setting** | Since we are governed democratically, it is essential to learn how to live under this system. We cannot take for granted that this is an “automatic” process.

To a vast number of people the meaning of democracy as far as it concerns them has come to mean casting a secret ballot, and even this right is not exercised in many instances. We talk glibly about our rights as citizens, but are inclined to ignore the responsibilities that accompany those rights.

In Rover Scouting we must attempt to lead the members of the Crew to participate actively in community enterprises. This may be accomplished by talks and visits to ratepayers' associations, community associations, political rallies and by becoming members of citizens' committees where policies and plans are formulated.

We have already remarked on the democratic setting in the Rover Crew. Here it is necessary to allow the art of discussion to be developed where the individual may freely express his own opinions, but at the same time learn to live with others whose opinions differ.

### *Quest No. 24 — The Use of Leisure*

The amount of leisure time available to the individual in today's society has increased greatly compared with the situation ten years ago. There is every indication that, with the expansion of automation in industry, and labour-saving devices around the home, the individual of tomorrow may have an even greater amount of spare time at his disposal. Today, there is talk of the 32, the 30, and even the 28 hour work week. The use to which this leisure time is being put at present is an urgent social problem, which will be aggravated if the predictions of the shorter work week become a reality. The challenge that faces the leadership of youth today is to help these young people to learn to use their spare time wisely.

How much spare time does a young man really have at his disposal? Actually, not too much. For the young man who is still attending school, home studies, spare time work, semi-compulsory extra-curricular activities and home obligations tend to consume a good deal of his spare time. It is interesting to note that most of his spare time is organized for him. Compare this with the situation the young adult faces when he becomes independent of the pressures which compel him to participate in teen-age activities. When the young adult has finished his day's work, his time is his own.

Historically, the idea behind the shorter work week has been to give citizens of a country the opportunity to enjoy the fruits of their labours. This can be interpreted two ways. In our spare time we can sit back and be entertained without making any contribution to our medium of entertainment or we can be creative and contribute to our own enjoyment. There are dangers to the first alternative. Spectatoritis and conformity to mass appeal are probably the greatest dangers since they negate individuality. Training in the use of leisure time can contribute greatly to the fullness of life for the individual and the general welfare of the nation. Being a citizen of a nation is really a great deal more than being merely a resident of the country. Citizenship implies the privilege of contributing to the life of the nation as well as the right to enjoy what the nation has to offer.

To illustrate this point, ask a group of people to name a good citizen. More than likely they will not name Joe Doakes, who pays his taxes, casts his ballot, and is a law abiding citizen. No, they will select some man who has done something that has benefited others, or who has made an outstanding contribution to national life. Someone, in other words, who has been of service to others.

The “rocks” outlined in **Rovering to Success** should be studied, as these indicate how leisure time can be used unwisely to the detriment of the individual and perhaps others. The antidotes to these hidden dangers are also outlined in **Rovering to Success** and the balance of this Quest is an elaboration upon what is suggested in that book.



ROVERING IS ONE OF MANY LEISURE ACTIVITIES

tooling, ceramics, plastics, plastic moulding, wood carving, stamp collecting, painting and sketching, and any of the building crafts. The designing and making of camping gear is a useful hobby and also has the advantage of tying in with Rover Scouting.

**Recreation** | Recreation in its true form means active participation.

The Crew will have its own recreation programme which will include such things as hiking and camping, and may include such social sports as golf and tennis.

The planning of Crew activities will provide the basis for training the Rover to participate in other recreational programmes.

Community recreational programmes may include such things as square dancing, ballroom dancing, adult sports, and supervision of juvenile sports such as Little League Baseball.

**Beauty** | As part of our effort to help young men look wide it is necessary to lead them to explore many things. This will include such things as art, literature, drama, and music. There is a tendency to decry

any new form of art because it is new and not understood. Conversely, some forms of art are praised because they are popular. It is not the job of the Rover Scout Leader to pass judgement on any form of art, but it is desirable to have the Crew make an honest attempt to acquire an appreciation of all forms of art. Governments and private interests support all forms of art, and generally the institutions established to foster the arts are willing to open their doors to the inquisitive and offer expert advice, usually without any charge.

Reading for pure enjoyment has been a spare time activity for millions of people and yet many do not read books. Rover Scouts should be encouraged to belong to the public library and to develop an appreciation for good literature.



**Theatres, Movies, Radio and T.V.** | This passive form of entertainment has its place, but like other good thing there is always a tendency to overdo it, or use it unwisely.

Theatres, movies, radio, and T.V. are forms of mass communication which affect our daily lives to a degree that was undreamed of at the turn of the century. If we wish, we may accept what they have to offer, enjoy their message without question and become passive conformists. On the other hand, we may question and evaluate the implications of these forms of entertainment. For example, the Crew may wish to form a study group to evaluate the performance, the story told, the characters or actors of some particular play. If some debate is being aired, the Crew may listen and, after the programme, continue the debate among themselves. Radio programmes, such as Citizens' Forum, can provide very useful material for round table discussions or debates.

**Balance** | Once again it is worth emphasizing the need for a balance of interests. There is always a tendency to pursue some activity in which we are interested, to the exclusion of all others. While it is very worthwhile to become an expert in some subject, it is just as important to look wide and explore everything that life has to offer. Naturally enough, some things will be rejected, but that is no excuse for not giving them a try and making an honest effort to understand them.

CHAPTER EIGHT

***Important Principles***

---

*Quest No. 25 — Duty to God*



Duty to God has, quite rightly, pride of place in our Promise. It follows then that duty to God should be equally prominent in Rover Scout Crews' activities. It is expected that the Rover Scout Leader will take the lead in bringing duty to God into the life of the Crew, but we must not forget that the Rover Scout Leader must set a good example. If a leader pays no attention to this he fails miserably.

**Policy** | The religious policy of our Movement is that every member is expected to belong to a religious denomination and to faithfully carry out his religious duties. This applies to all, whether Wolf Cub, Boy Scout, Rover Scout or Scouter. Surely the foregoing statement is clear and leaves no room for doubt as to the intent. It could not be stated more simply. One of the obligations undertaken by the Rover Scout in his Investiture is to show his younger brothers an example worthy of his best self. His best self should certainly place his religious life right at the top of the list. Actually, when a Rover Scout ignores his duty to God, the public manifestation of this being attention to his church responsibilities, he is failing to live up to his Promise.

**Practical Ideas** | From time to time, the question arises how can we bring duty to God into the Rover Scout Crew activities. The Chapter on Ceremonies deals with this to some extent. Prayers at the end of the meetings, reading some Hold Scripture passage which has been carefully chosen, grace before meals and well-conducted Scouts' Owns are means whereby duty to God may be brought before the Crew if the religious background of the members of the Crew permits.

If a young man joins a Crew and says that he has no church affiliation, it is the Rover Scout Leader's job to encourage the young man to become a member of a church. One must walk carefully in these cases as the boy's parents may have some preference as to which church their son should join.

Other ways to exemplify duty to God include special services and church parades, provided that the church parades are held to glorify God and not to glorify the Boy Scouts Association. In many Crews there are lads of different denominations, and care must be exercised that there is no coercion to take a

Rover Scout away from his own church. Because of denominational differences it is difficult to arrange corporate Communion services and parades, but the difficulty can be overcome by arranging that each Rover Scout will attend his own church on the same day at or about the same time. On the other hand, if the entire Crew are members of one denomination, there is no problem.

It is good to encourage Rover Scouts to take an active interest in their church's life. There is no reason why the Rover Scouts cannot take on the job of sidemen or ushers on specified dates, offer their services as Sunday School teachers, or sing in the choir if they have the gift of a good singing voice. But whatever church job is undertaken it should be commensurate with the Rover Scout's age and ability.

It is accepted that one of the best means of establishing a man's churchmanship is to give him something to do in connection with church life; no doubt every Crew could, as a whole, or as individuals, find some service they could render.

**Helping the Non-Believer** | A problem which might arise in any Crew is the lad who has not gone to church because he is a doubter. It is not possible to suggest a cure which will work with everybody. It is the job of the Rover Scout Leader to help the young man to straighten out his thinking. Have him read and study the section on Irreligion in **Rovering to Success**.

It is important to remember in dealing with these problems that Scouting never was, and was never intended to be, a religion. Scouting is supplementary to the church, in the same way it is supplementary to the school and home.

If the Rover Scout Leader feels that he needs help in dealing with religious matters, particularly with fellows who are uncertain in their beliefs he could call for help from a minister of the church, being assured beforehand that the minister is the type who will be sympathetic.

But no matter how inadequate the Rover Scout Leader feels he should most certainly have some talks with the uncertain ones. The Rover Scout Leader may uncover talents of which he was unaware. After all, if the Rover Scout Leader has faith and is true to his religion he should be able to do much by his example to keep duty to God prominently before the Crew which he has the honour of leading.

This Quest started with a reference to the importance of setting a good example and without any preconceived plan it ends on the same note. Perhaps it is good for all leaders to be reminded that so many of the things which go towards building character are caught rather than taught. It is a splendid experience to be placed in a position where our actions and words are potent factors in helping to mould character. It is also a challenge, and a worthy one.

### *Quest No. 26 — Duty to Queen*

The sequence of thought in the Scout Promise is another example of the genius of our Founder. The wording is simple and direct and the sequence is well planned; duty to God first of all, then duty to the Queen, who represents the duly constituted laws of our country, followed by duty to our neighbours.

Rover Scout Leaders would do well constantly to remind themselves of the obligations and responsibilities inherent in the Promise. It is so easy when one gets embroiled in some activity or another, or becomes deeply concerned in some organizational problem, temporarily to forget why we are in the game of Scouting and what we are trying to accomplish, and so lose a sense of proportion.

We should be proud of the fact that Scouting has survived and flourished during one of the greatest half-centuries of upheaval in history. We should recall with some pride as well as thankfulness that in 1914 we were only six years old but despite heavy inroads into our leadership ranks, we came through the period 1914-18 stronger than ever. The same story can be told of World War II. With the apparently increasingly alluring temptations facing young men of Rover Scout age, Rover Scout Leaders have a big job on their hands.

**Duty Defined** | Duty has been defined as “something that ought to be done; moral or legal obligation”. We can go further and put forth the thought that implied in the word duty are truth, honesty, honour, loyalty, and faith.

It might be well to take the foregoing definition of duty and examine it word by word.

**Truth** | We must ourselves be true to the principles of good government before we attempt to teach others. If we see any individual in authority denying truth, whether in local, provincial, or federal fields, it is our duty to do what we can to correct that evil. Rover Scouts should be encouraged to take part in Crew discussions on government matters, and in their contacts with other people and organizations to maintain an honest approach.

**Honesty** | We must be honest not only in matters that are apparent but also in the small things which can be camouflaged. For example, smuggling small parcels across the border is looked upon by some people as a sort of game; if the customs officers have been fooled, the smuggler wins. This may be exciting, but the plain fact is that it is dishonest, and a violation of our duty to our country. It is true that the strength of our nation is weakened by every unlawful act, large or small.

It is not possible to tell how far our actions reach in their influence on others. There was once a district camp in which some petty thieving was troubling the camp staff. Finally they traced it to one Patrol Leader. On being asked why he had stolen the relatively small items, none of them personal property but items of general utility such as a hand axe, small shovel, and extra cooking pot, he admitted that he had heard his father boast of the many articles which he had “won” during his army career. He, the father, thought it great fun; he did not consider it stealing as the property belonged to the government; actually it was the property of the King. So his son, emulating father, made a bit of a nuisance of himself. It is easy to say, “It is the Government’s so it belongs to us”, or boast about having “gypped” the Income Tax people, but again it is plain dishonesty and an infraction of duty to our country.

It may have to be brought to Rover Scouts’ notice that infraction of local laws, no matter what they are, constitute breaking that section of the Promise called duty to the Queen.

**Honour** | Surely we do not need to enlarge on the implications of Honour. The Rover Scout who has come up through Pack and Troop knows perfectly well what is meant by honour. Yet it is exactly this trait, or one should say the ignoring of it, that tests one’s loyalty. For example, a man can be out on a distant lake enjoying grand fishing. He has his official take for the day, but the fish are biting well. He is miles from a game warden. Does he stop, or does he keep on fishing? It is all a matter of honour. He can continue fishing, breaking the law and incidentally ignoring his duty to the Queen, or his honour can take over and he’ll pack up and go back with his official bag limit and no more. Members of our Association are fortunate to belong to an organization which demands the best from them; a Promise and a Law written in simple language. Every Rover Scout must guard his honour faithfully.

**Loyalty** | Our heritage of Constitutional Government personified by our gracious Queen is a stirring drama in which every Rover Scout should be encouraged to develop an interest. Rover Scout Leaders would do well to look again at the aim of our programme which, in the words of the Founder, is, “To

develop good citizenship among the boys by forming their character". Through Rover Scouting we have a wonderful means of developing a sense of loyalty and understanding of that to which young men should be loyal. There is a great need to develop within our Rover Scouts a sincere pride in their country based on a thorough understanding of its past, present and potential future. This is not to say that we should strive to develop a narrow nationalism but rather a pride in our country as one member of an international community. Through the brotherhood ideal of Scouting we have a wonderful opportunity of developing a sense of world-wide responsibility and loyalty to our fellow men. Rover Scout Leaders would do well to make themselves aware of the tremendous contributions made to the world-wide community by the various agencies of the United Nations. One has but to look at the accomplishments of agencies like UNESCO and UNICEF, allied as they are with the work of The Boy Scouts Association throughout the world, to see the tremendous value in developing loyalty to the international community.

With subversive elements making a determined effort to undermine our economy by various means — slander, whisper campaigns, and so forth — it is of extreme importance that Rover Scouts direct their thinking along truly constructive lines. Loyalty to our Queen and country means adherence to laws and customs, some perhaps of little import, but they are laws and must be observed.

**Faith** | The future of our nation depends on the work of men of faith, in the past, present and future. Decadent civilizations had one thing in common — citizens and leaders deserted their faith in the future for the pleasures of the present.

Rover Scout Leaders are charged with the task of stimulating and encouraging faith and pride in our country in the heart of every Rover Scout. These clear-thinking, self-reliant young men should be able and eager to work for the national good in all circumstances — peace, war, or disaster.

**Practical Ideas** | Far too many citizens go through life unaware of how they are really governed, or of their relationship to the state. And yet a person must be aware of these facts if he is to be loyal to his Queen and country; otherwise he will not know to what he is to be loyal. In other words, what do the words "Queen and country" stand for? Is it not more than mere government? Does it not encompass our natural resources, transportation, banking, laws, customs — daily conduct of one to another? Our society?

Yes, it is all-embracing in our daily lives. Therefore, to make duty to the Queen a reality, Rover Scouts must engage in adult activities that will bring them into contact with many facets of living.

Visits to police stations and courts of law; talks by lawyers, policemen and detectives; joining and training for the auxiliary police service; will bring the young men into contact with our law enforcement agencies.

Conservation practices for water, soil, wildlife, and forests will help the Rover appreciate his heritage.

Visits to armed services camps and training establishments will illustrate our system of National Defence. Perhaps a young man, and particularly the young man of limited means, may wish to take advantage of officer training to further his education while serving his country.

Attending town or city council meetings, visiting the Provincial Legislature or Federal Parliament are activities that every citizen should try to undertake to see what actually is done on our behalf by our elected representatives. How are laws made? How is the tax structure made up?

Safe driving lessons could also be taken by Rovers, and if they are really ambitious they could invite their parents and friends (boy and girl) to participate.



Practical ideas for teaching “Duty to Queen” are endless. It only takes a little imagination to translate ideas gleaned from the Rover Scout Leader’s daily life into an activity for his Crew.

### *Quest No. 27 — Duty to Neighbour*

“Service is the rent we pay for our room here on earth.”

Service is not only the motto of Rover Scouting, it is the golden thread running through the warp and woof of the fabric we know as Scouting, giving it warmth and beauty. From the time that a boy makes his Wolf Cub Promise, then makes his Promise as a Boy Scout and as a Rover Scout, the idea of service to others is there, commensurate with increasing age and ability. This is as it should be; as has been said many times, the Wolf Cub “does his best” to “be prepared” as a Boy Scout, for “service” as a Rover Scout.

**Good Turns** | It is obvious that Good Turns as undertaken by Rover Scouts should be of a high order and performed competently. No matter what the job is, the Crew should study the assignment to make sure that they can tackle it. Such matters as who will do the job, how often, for how long, need to be settled, so that the service is rendered effectively.

At times the Crew may have to look for Good Turn opportunities as did a Crew who got in touch with the local social service people. From the social service office they got a list of old age pensioners who really did need help, so the Crew divided the list, each Rover taking three or four names. They made regular visits to these older citizens to see what they could do to make life easier. They received all sorts of requests for odd repairs, do special shopping and so forth.

The members of this Crew were mostly university students, and this experience was good for them. They saw a side of life to which they might not have been exposed. In due time, they took a fairly prominent part in local affairs. Their association with these older citizens had an important effect on their thinking and actions when they assumed positions of authority. This is another example of how people who perform service receive personal benefit.

**Service to Scouting or Self?** | There is also service to Scouting which must be considered. It should not be difficult to find opportunities for service to Packs or Troops. Again it should be noted that the Rover Scout giving service within the Movement benefits by training himself in the art of leadership or, better still, by taking one of the training courses available.

But, with all this, care must be taken that Rover Scouts do not spend too much time on Scouting to the detriment of their chosen careers. It has been said time and time again that a Rover Scout’s first duty is to himself. He will wish to make a living and, naturally, he will be ambitious to make the best living possible, but over and above this desire, he will, we hope, have some ambition to take an active part in community life. Usually the man who is listened to most is the man of integrity — the man who is known as a success in his chosen calling.



It might be well to offer a warning, however, about developing a sanctimonious attitude just because we happen to have done a few Good Turns or performed some public service. The attitude should be one of thankfulness that the opportunity came our way, even if, as sometimes happens, no recognition was made and no thanks given. It is very nice to be commended, but the main thing is to do the job well.

**What is Service?** | In Chapter Seven the Quest of Service is discussed. It is worth repeating that Service is an attitude and not a series of planned activities designed to help others. However, by planning and performing Good Turns, an attitude for service may be developed.

The real test of an attitude for service is when an individual is faced with the opportunity of helping others when the circumstances are distasteful or even dangerous and when no one will be the wiser whether or not the act is done, except the person who must make the decision.

### *Quest No. 28 — The Promise and Law*

The Scout Promise and Law are the foundation of the Boy Scout Movement. By making the Promise a person becomes a member of the Movement and becomes bound by the conditions of that Promise to act in certain ways. The making of the Promise is the outward sign of intention to do certain things.

So far, the understanding of the Law and Promise is quite simple. Furthermore, the actual wording of the Law and Promise appears to be equally as simple.

**Interpretation** | Now — what do The Promise and Law really mean? What does the promisor promise to do?

Here is Baden-Powell's interpretation for young men:

“On my Honour — your Honour must be a very sacred thing to you, a thing that will rule your conduct as a man. It means that you can be trusted implicitly to do what you know is right or what you agree to undertake.

“I promise — this particular promise is a solemn undertaking, not to be taken lightly even by a boy, still less so by a young man. Therefore, think it over carefully before embarking on it.

“To do my best — this means that though circumstances may hinder you from doing it as completely as you wish, you will, at any rate, try your utmost.

“To do my duty to God — What is your duty to God?

“To put it briefly, it would seem to be to try in the first place to realize the nature of God, and, secondly, to develop and use, for good purposes only, the body which He has lent to you, to develop the talents of minds and intelligence with which He has endowed you and, especially, to cultivate and practise the spirit of love and good will to others, the part of Him which is within you, that is, your soul.

“And to the Queen — that is, to your country, under the leadership constituted by the will of the majority.

“To help other people at all times — thus putting into constant and active practice the divine law of loving your neighbours as yourself.

“To obey the Scout Law — To obey the Scout Law does not mean to sit down passively in a state of goodness, but to improve your own character and actively to practise Love (which underlies the Law) in all your daily activities.”

**The Law** | “The term Rover Scout stands for a true man and a good citizen. The Law for Rovers is the same as for Scouts in working and principle, but has to be viewed from a different standpoint — that is, from that of a young man. In both cases the principle underlying the Scout Law takes out Self and puts in Good Will and Helpfulness to others. Don't take this as instruction in Piety, but as direction to Manliness.

“A Scout's Honour is to be trusted — As Rover Scout, no temptation, however great or however secret, will persuade you to do a dishonest or a shady action, however small. You won't go back on a promise once made.

“A Rover's word is as good as his bond.”

“The Truth, and nothing but the Truth for the Rover.”

“A Scout is loyal to the Queen, his officers, his parents, his employers, and those under him — as a good citizen you are one of a team “playing the game” honestly for the good of the whole. You can be relied upon by the Queen, as head of the Commonwealth and Empire, by the Scout Movement, by your friends and fellow workers, by your employers or employees, to do your best for them — even though they may not always quite come up to what you would like of them. Moreover, you are loyal also to yourself; you won't lose your self-respect by playing the game meanly; nor will you let another man down.

“A Scout's duty is to be useful and to help others — As a Rover Scout your highest aim is **service**. You may be relied upon at all times to be ready to sacrifice time, or, if need be, life itself for others.

“Sacrifice is the salt of Service.”

“A Scout is a friend to all and a brother to every other Scout — As a Rover Scout you recognize other fellows as being, with yourself, sons of the same Father, and you disregard whatever may be their differences of opinion or caste, creed or country. You suppress your prejudices and find out their good points; anyone can criticize their bad ones. If you exercise this love for men of other countries you help to bring about international peace and good will, that is, God's Kingdom on earth.

“All the world's a Brotherhood.”

“A Scout is courteous — Like a knight of old, you are, as a Rover, of course, polite and considerate to women, old people, and children. But more than this, you are polite also even to those in opposition to you.

“Whoso is in the right need not lose his temper; whoso is in the wrong cannot afford to.”

“A Scout is a friend to animals — You will recognize your comradeship with God's other creatures placed, like yourself, in this world for a time to enjoy their existence. To ill-treat an animal is therefore a disservice to the Creator.

“A Rover has to be big-hearted.”

“A Scout obeys orders without question — As a Rover Scout you discipline yourself and put yourself readily and willingly at the service of constituted authority for the main good. The best disciplined community is the happiest community, but the discipline must come from within, and not merely be imposed from without. Hence the greater value of the example you give to others in this direction.

“A Scout smiles and whistles under all difficulties — As a Rover Scout you will be looked to as the man to keep your head, and to stick it out in a crisis with cheery pluck and optimism.

“If you can keep your head when all about you  
Are losing their and blaming it on you...you'll  
be a Man, my son.”

“A Scout is thrifty — As a Rover Scout you will look ahead and will not fritter away time or money on present pleasures, but rather make use of present **opportunities** with a view to ultimate success. You do this with the idea of not being a burden, but a help to others.

“A Scout is clean in thought, word and deed — As a Rover Scout you are expected to be not only clean minded, but clean willed; able to control any sex tendencies and intemperances; to give an example to others of being pure and above board in all that you think, say, and do.

“There is to the Scout code an eleventh Law, an unwritten one, namely, “A Scout is not a fool”. But this I should hope would be unnecessary as a code for Rovers. Still, as a Rover you have to remember that in crossing the threshold from boyhood into being a man you are no longer learning to carry out the Scout Law, but are actually using it for guidance of your conduct in life. More than this, you are now in the responsible position of giving an example to others, which may lead them to good or to evil, according to whether or not you model your conduct on the Law, and how far you carry out that promise which you have made, on your honour, as a Rover Scout, to give out good will and help to all.”

Now, the real problem of interpretation and application is to translate what has been said into the life of the Crew and the day-to-day life of each member of the Crew. This is the hard core of the Rover Scout Leader's job — and it is not an easy assignment.

## CHAPTER NINE

### **Success**

---

**Disappointments** | Throughout this book it has been stated that your job as a Rover Scout Leader will be rich and rewarding. Don't let that though lead you to the conclusion that the leadership of young men is a bed of roses. Far from it. You will have disappointments — some of which will be very discouraging and may lead you to say, “What's the use”.

For example, the Crew may commit itself to some undertaking in which others are involved and at the last moment will back out for reasons which you feel are totally inadequate. It is possible that you will feel a keen sense of being let down and even feel that you have lost face with the adults who were counting on you. Your leadership has been challenged and you have lost.



This type of disappointment may happen. “The best-laid schemes o’ mice an’ men gang aft agley.” True, it shouldn’t happen and, as the members of the Crew mature and become experienced in assessing their abilities, and form better judgements, it will not happen. Until the members of the Crew reach that happy state, the irresponsibility of youth must not be the Rover Scout Leader’s disappointment but his challenge. Careful thought must be given and wise counsel offered for all activities which involve others.

So much for the negative outlook on the topic of Success. Now let us look at the positive side.

Success is the end result of Rover Scout training. We are *Rovering to Success*. This does not happen suddenly, but is the result of extreme patience on the part of the Rover Scout Leader, a sincere desire to be of service to youth which temporarily setbacks will not dampen, and a faith in the possibilities of each young man in the Crew. The long view must be taken.

**Signs of Success** | How can a Rover Scout Leader tell when he is succeeding with his leadership of the Crew? His success is measured by the success of the individuals in

the Crew. The Founder of Scouting gave us a clue when he wrote the following in **Rovering to Success**:

“As I write these lines there is, camping in my garden, a living example of what I hope may be the outcome of this book, on a wider scale.

“With all my heart I hope it.

“He is a hefty Rover Scout, about eighteen years of age, that is a fellow training to be a man. He has tramped from a distance with a pack, in which were his light tent, his blanket, cooking pot, and food. He carries on him his axe and lariat. In his hand a serviceable staff with a weirdly carved head, his own handiwork.

“In addition to this load he carries a still more important thing — a happy smile on his weather-tanned face.

“He slept out last night in bitter wind and rain, although I gave him the choice of living under a roof. He merely remarked, with a laugh, that it had been a hot summer, and a little cold wind was a change and would do him good. He cooked his own meal, and made himself all snug with all the resourcefulness of an old campaigner.

“Today he has been showing our local Scouts how to use the axe with best effects, and he proved to them that he could “rope” his man unerringly with his lasso. He knew the trees by their bark and the birds

by their note. And he could climb any tree or crag that he came across. Altogether a healthy, cheery, skilled young backwoodsman. Yet this chap is a “Townie”, but one who has made himself a Man.

“As he admitted to me, he is in his ordinary life an apprentice in some engineering works in the big city. He enjoyed getting out into the open not merely because it was a relief from his work, for his work interested him but because it took him out of the filthy talk and foul language that was supposed by his fellow-workers to be the manly thing to carry on.

“He told me he had got a “thick ear” more than once for not taking part in it, and he had managed to deal out a “thick ear” or two on his part in urging cleaner thought.

“But he had gone further than this. His example, rather than his punch, had led two or three of his mates to take an interest in his ideas and his hiking, and they were now becoming Rovers like himself.

“Through his own example he was giving these chaps a new outlook on life and something jollier and higher to live for. So he is doing Service too.”

Success as a Rover Scout Leader can be yours if you stick with it and honestly help each young man to place his own two feet firmly on the road to good citizenship. It will take time — but it will come to pass.

## *Appendix*

**History** | Rover Scouting was born because there was a demand for it.

Young men wanted to do things suitable to their ages, abilities, and interests. They found that the programme of the Boy Scout Troop was too juvenile for their tastes, and it did not satisfy their desires. Some Scoutmasters recognized the great difficulty in maintaining the interest of these older boys within the Troop programme and were sympathetic with their wishes. Other Scoutmasters found their Troop average age was growing progressively older and that young boys no longer joined them. Husky, mustached Patrol Leaders were causing real problems in these Troops. Often it reached the point where very few boys in the Troop could ever hope to become Patrol Leaders and thus develop their latent leadership possibilities which is part of the training method in the Boy Scout Troop.

Leaders of the Movement also recognized the need to provide a bridge between the boy world and the adult community to interpret the boy-principles of the Movement into adult terms and to ensure that they became a guiding force in the life of the mature man.

A series of experiments was conducted, and in 1916 the original pamphlets about Rover Scouting appeared. In 1917 Rover Scouting was launched officially as the third Section of the Movement. The original plan for Rover Scouts established the joining from 15½ to 16 years. From time to time this age limit has been raised, but following the Second World War it reverted to 16.

In 1918 the aims and the spirit of Rover Scouting were developed and presented to the Movement when Baden-Powell wrote and had published **Rovering to Success**. From the very beginning **Rovering to Success** and **Scouting for Boys** were meant to be companion volumes in the training of young men.

While **Scouting for Boys** presented a programme of woodcraft for boys and young men, **Rovering to Success** never pretended to present a programme to tell us about Rovering. In Baden-Powell's own words he states:

"It always seems to me so odd that when a man dies he takes with him all the knowledge that he has got in his lifetime whilst sowing his wild oats or winning successes. And he leaves his sons or younger brothers to go through all the work of learning it over again from their own experience. Why can't he pass it on so that they start with his amount of knowledge to the good to begin with, and so get on to a higher scale of efficiency and sense right away?"

"It is with that sort of idea in mind that I feel induced to jot down a few of the difficulties that I have come across in my time, and tell how I have found it best to deal with them."

B.-P. then goes on to explain to young men his philosophy of living. The greater part of his book is taken up with the difficulties, or rocks, with which he had come into contact during his lifetime. They include the subjects of horses, wine, women, cuckoos and humbugs, and irreligion. **Rovering to Success** does not set forth an explanation of how Rover Scouting is operated, but it certainly passes on valuable advice to the young man who reads the book, from a great man who did himself rove to success.

The history of Rover Scouting has had many complications and problem, both national and international.

It is necessary to continue to look to **Rovering to Success** for the spirit of Rovering. In **Scouting for Boys** are found the training values of the school of woodcraft. This book will help a leader organize and operate his Rover Crew, and develop a greater understanding of the nature of the job so that the aim may be achieved.

The leader of a Rover Crew has one of the most important and challenging fields of endeavour in the entire Boy Scout Movement. To be guide, counsellor, and friend to young men who have reached the crossroads of life can be a most rewarding experience. It is also a great responsibility and a high privilege.

